

HOUSINGS AND ACCESSORY PRODUCTS

HP16-21 Hand Pump

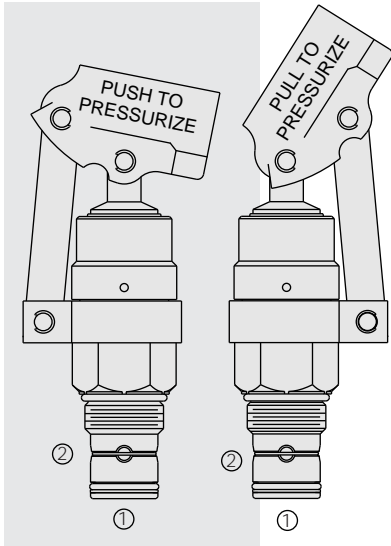

DESCRIPTION

A screw-in, cartridge-style, push or pull type hand pump with two built-in checks.

OPERATION

The **HP16-21** provides hydraulic flow to 1.3 cu. in. per stroke, at pressures to 96 bar (1500 psi).

Note: As with any mechanical hydraulic actuator (piston rods, rotating pump shaft, etc.) the shaft will become coated with a minute amount of oil from the internal high pressure system. The rod protruding from the hand pump may feel damp with oil after use. This is desirable because the oil coating serves to lubricate the shaft seal, reducing friction and assuring extended seal life.

FEATURES

- Hardened parts for long life.
- Handle Beam rotates 360°
- Push or pull linkage standard.
- Heavy duty construction.
- Industry common cavity.
- Displacement up to 21.3 cc (1.3 cu in.) per stroke.

RATINGS

System Pressure: 207 bar (3000 psi)

Pressure Generated by HP16-21: 96 bar (1500 psi) maximum

Proof Pressure: 345 bar (5000 psi)

Internal Leakage: From port ② to the inside of the pump: 5 drops/minute (0.25 cc/minute) max. at 207 bar (3000 psi)

Suction Pressure: 194 mm Hg (7.6 in. Hg, 104 in. H₂O) less than atmospheric pressure

Temperature: -40 to 120°

Filtration: See page 9.010.1

Fluids: Mineral-based or synthetics with lubricating properties at viscosities of 7.4 to 420 cSt (50 to 2000 sus)

Installation: No restrictions; See page 9.020.1

Cavity: VC16-2; See page 9.116.1

Cavity Tool: CT16-2xx; See page 8.600.1

Seal Kit: SK16-2x-T; See page 8.650.1

Seal Rating: 125,000 cycles

Handle Kit: 16 in. handle, 2.65 kg. (1.2 lbs.)
Part no. 6502340; Must be ordered separately

SYMBOLS

USASI/ISO:

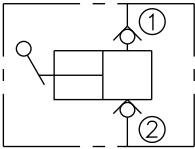

PERFORMANCE (Cartridge Only)

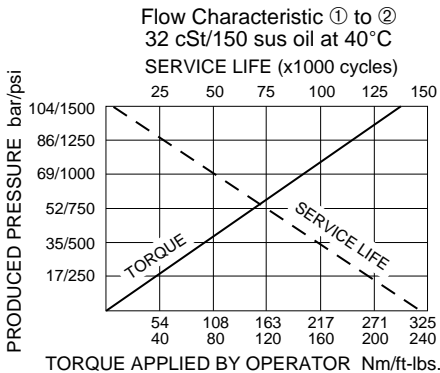

DIMENSIONS

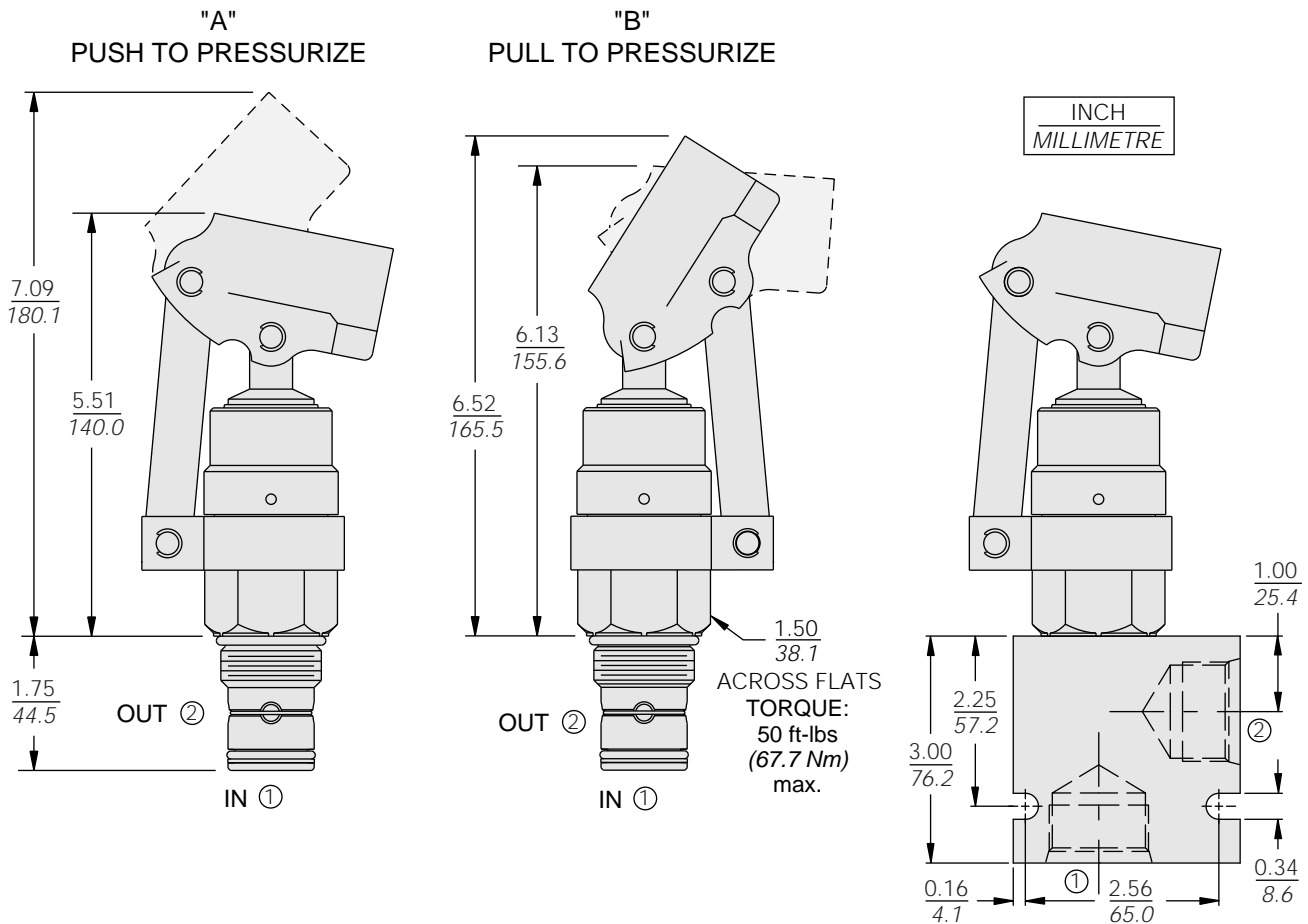

MATERIALS

Cartridge: Weight: 1.27 kg. (2.8 lbs.)
Steel with hardened work surfaces.
Zinc-plated exposed surfaces.
Buna N O-rings and polyester elastomer back-ups standard.

Standard Ported Body: Weight:
0.57 kg. (1.25 lbs.) Anodized high-strength 6061 T6 aluminum alloy, rated to 207 bar (3000 psi). Ductile iron bodies available; dimensions may differ. See page 8.016.1

TO ORDER

HP16-21 - -

**Push or Pull

Push Handle Actuation **A**
Pull Handle Actuation **B**

*Shipped as kit for installation

Handle Kit Part no. 6502340;
Must be ordered separately.

Seals

N Buna N (Std.)
V Fluorocarbon

Porting

0 Cartridge Only
12T SAE 12
16T SAE 16
6B 3/4 in. BSP*
8B 1 in. BSP*

*BSP Body; U.K. Mfr. Only