

CR10-28 Relief, Bi-Directional

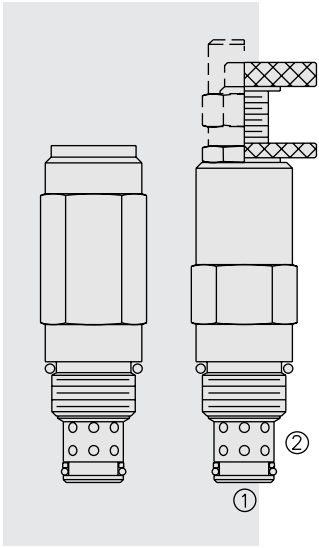

DESCRIPTION

A screw-in, cartridge-style, direct-acting, differential area, poppet-type, bi-directional relief valve.

OPERATION

The **CR10-28** is a direct-acting, dual cross-over relief valve in a single cartridge format. When pressure at either port exceeds the nominal setting value, flow will be transmitted to the opposite port. Back pressure at either port will affect the nominal setting of the opposite port on a 1:1 basis.

For correlation purposes, pre-set value will be measured at port ②. Pressure at port ① will not exceed ± 150 psi from the port ② value.

FEATURES

- Adjustments cannot be backed out of the valve.
- Adjustments prohibit springs from going solid.
- Hardened parts for long life.
- Industry common cavity.

RATINGS

Maximum Operating Pressure: 240 bar (3500 psi)

Adjustable Pressure Range: 14 to 210 bar (200 to 3000 psi); Two springs; Pressure is set at port ②

Proof Pressure: 345 bar (5000 psi)

Reseat Pressure: 90% of crack (crack pressure at 0.95 lpm/0.25 gpm)

Maximum Difference for Crack Pressure in Both Directions: 10.5 bar (150 psi)

Flow Range: 60 lpm (16 gpm); see performance chart

Maximum Internal Leakage: when reseal to 80% of crack pressure: 33 ml/minute (2 cu. in./minute)

Cycle Limitations: Internal seal life is limited to 300,000 cycles in either direction at maximum setting

Temperature: -40 to 120°C with Buna N seals

Filtration: See page 9.010.1

Fluids: Mineral-based or synthetics with lubricating properties at viscosities of 7.4 to 420 cSt (50 to 2000 sus); See Temperature and Oil Viscosity, page 9.060.1

Installation: No restrictions; See page 9.020.1

Cavity: VC10-2; See page 9.110.1

Cavity Tool: CT10-2XX; See page 8.600.1

Seal Kit: SK10-2X-B; See page 8.650.1

SYMBOLS

USASI/ISO:

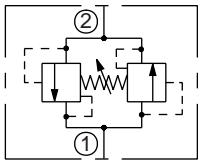

PERFORMANCE (Cartridge Only)

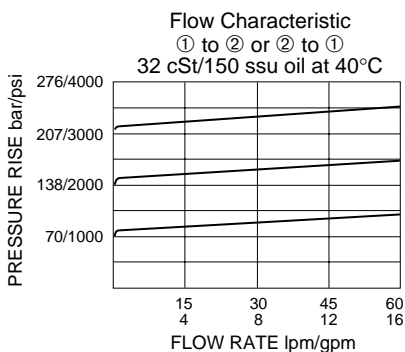

DIMENSIONS

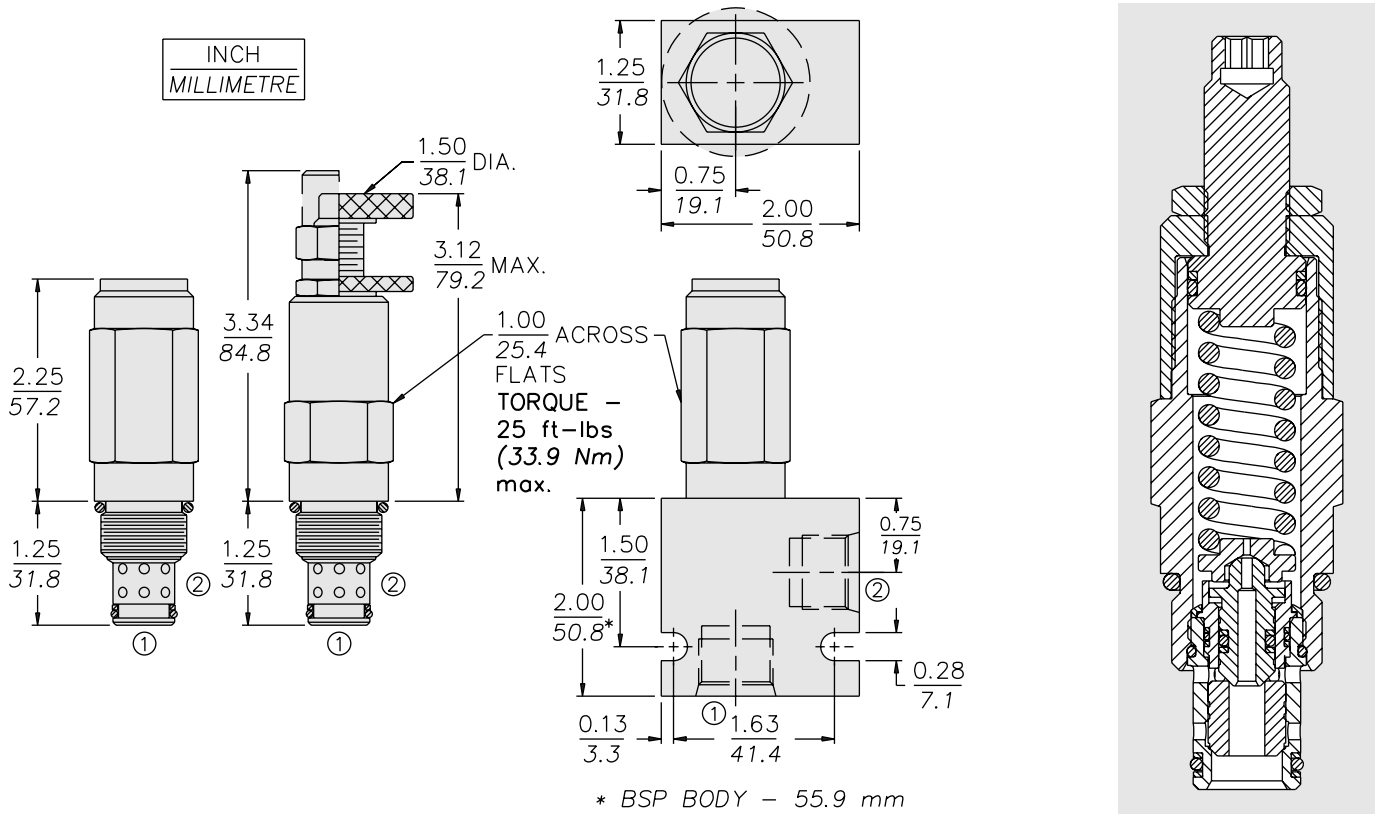

MATERIALS

Cartridge: Weight: 0.22 kg. (0.5 lbs.)
Steel with hardened work surfaces.
Zinc-plated exposed surfaces.
Buna N O-rings and TFE backup
standard. Anodized aluminum knobs.

Standard Ported Body: Weight:
0.16 kg. (0.35 lbs.) Anodized high-
strength 6061 T6 aluminum alloy,
rated to 207 bar (3000 psi). Ductile
iron bodies available; dimensions
may differ. See page 8.010.1

Note: Orifice Disc should not be used
with this product.

TO ORDER

CR10-28

Adjustment Option

1/4 in. Hex Allen Head **A**
1-1/2 in. Dia. Alum. Knob **B**
Option A w/ Cover Cap **C**
Factory Preset Non-Adjst. **F**

Factory Preset
Hidden Adjustment **H**
Option C
w/Lockwire Holes **L**

Porting

Cartridge Only **0**
SAE 6 **6T**
SAE 8 **8T**
3/8 in. BSP* **3B**
1/2 in. BSP* **4B**

*BSP Body; U.K. Mfr. Only

Seals

N Buna N (Std.)
V Fluorocarbon

Setting in bar[†]

(Blank) for Adjustable, or
Specify, for example:

M25 25 bar
M100 100 bar

Setting in psi[†]

(Blank) for Adjustable, or
Specify, for example:

9.0 900 psi
23.5 2350 psi

Spring Range

24 14 to 168 bar
(200 to 2400 psi)
30 160 to 210 bar
(2300 to 3000 psi)

[†]Adjustable valves will be
preset to approx. 50% of
spring max. potential.