

# RV10-22 Relief, Differential Area Poppet

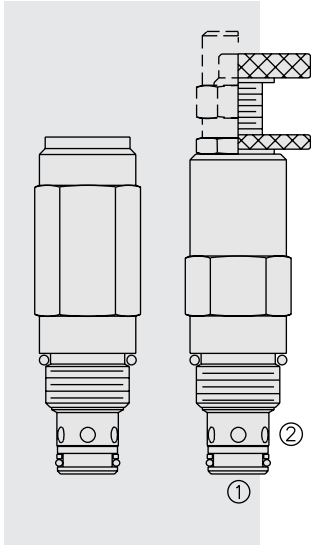

## DESCRIPTION

A screw-in, cartridge-style, direct-acting, differential area poppet-type hydraulic relief valve for use as a pressure limiting device in more demanding hydraulic circuits, requiring low hysteresis and low internal leakage.

## OPERATION

The RV10-22 blocks flow from ② to ① until sufficient pressure is present at ② to force the poppet from its seat.

The cartridge offers smooth transition in response to load changes in common hydraulic circuits.

Note: The RV10-22 may be used in cross-over relief applications (back pressure on ①) with the use of the "C" double back-up ring seal option. See Ordering Table.

## FEATURES

- Adjustments cannot be backed out of the valve.
- Adjustment options A, B, and C: positive stops prevent springs from going solid.
- Hardened poppet and cage for long life.
- Optional spring ranges to 241 bar (3500 psi).
- Smooth response to pressure surges.
- Industry common cavity.

## RATINGS

**Operating Pressure:** 241 bar (3500 psi)

**Flow:** The Performance Chart illustrates flow handling capacity at maximum setting for each spring range option. Pressure rise will vary with spring (range) and with setting within range due to flow forces. Consult factory for specific flow characteristic values.

**Pressure Rise:** 0.34 bar/l (5 psi/g)

**Internal Leakage:** 0.25 cc/minute (5 drops/minute) max. to 85% of nominal setting

**Crack (Set) Pressure Defined:** bar (psi) evident at 0.95 lpm (0.25 gpm) attained

**Standard Spring Ranges:** Due to manufacturing tolerances, it may be possible to adjust the valve either lower or higher than the nominal ratings shown below.

Spring Model Code	Nominal Factory Rating	Maximum Solid Adjustment
6	10.34 – 41.38 bar (150 – 600 psi)	55.17 bar (800 psi)
13	10.34 – 89.66 bar (150 – 1300 psi)	117.24 bar (1700 psi)
25	25.86 – 165.52 bar (375 – 2400 psi)	206.9 bar (3000 psi)
35	17.24 – 241.38 bar (250 – 3500 psi)	296.55 bar (4300 psi)

**Temperature:** -40 to 120°C

**Filtration:** See page 9.010.1

**Fluids:** Mineral-based or synthetics with lubricating properties at viscosities of 7.4 to 420 cSt (50 to 2000 sus); See Temperature and Oil Viscosity, page 9.060.1

**Installation:** No restrictions; See page 9.020.1

**Cavity:** VC10-2; See page 9.110.1

**Cavity Tool:** CT10-2XX; See page 8.600.1

**Seal Kit:** SK10-2X-T; See page 8.650.1; SK10-2X-M (for cross-over relief application)

## SYMBOLS

### USAS/ISO:

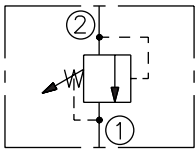

## PERFORMANCE (Cartridge Only)

