

FD10-41 Flow Divider/Combiner, Cylinder Synch.

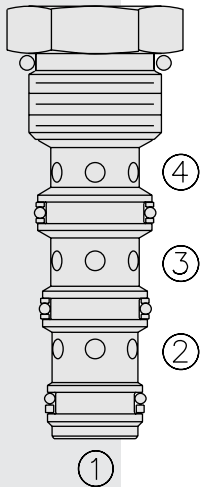

DESCRIPTION

A screw-in, cartridge-style, spool-type flow divider/combiner. Optional flow dividing/combining ratios are maintained regardless of system operating pressure conditions.

OPERATION

In the dividing mode, the **FD10-41** will divert input flow from port ③ to ports ② and ④, based on the ratio specified, regardless of operating pressure.

The cartridge will combine input flows from ports ② and ④.

The FD10-41 is designed to allow synchronizing flow to the opposite cylinder once a cylinder has "bottomed" in the combining mode.

FEATURES

- Hardened parts for long life.
- Quiet, modulated response.
- Industry common cavity.

RATINGS

Operating Pressure: 240 bar (3500 psi)

Flow: 45.4 lpm (12 gpm) input max.

Flow Options:

- Input Flow: 7.6 lpm (2 gpm); Ratio: 50:50; Model Code: 11
- Input Flow: 15.1 lpm (4 gpm); Ratio: 50:50; Model Code: 22
- Input Flow: 22.7 lpm (6 gpm); Ratio: 50:50; Model Code: 33
- Input Flow: 30.3 lpm (8 gpm); Ratio: 50:50; Model Code: 44
- Input Flow: 37.9 lpm (10 gpm); Ratio: 50:50; Model Code: 55
- Input Flow: 45.4 lpm (12 gpm); Ratio: 50:50; Model Code: 66

Other ratio options available; consult factory.

Standard Compensator Bias Spring: 2.07 bar (30 psid)

Flow Accuracy: 10% from 30–100% of rated flow

Temperature: -40 to 120°C

Filtration: See page 9.010.1

Fluids: Mineral-based or synthetics with lubricating properties at viscosities of 7.4 to 420 cSt (50 to 2000 sus); See Temperature and Oil Viscosity, page 9.060.1

Installation: No restrictions; See page 9.020.1.

Note: Standard 10 size 4-way bodies should not be used with this product.

See page 8.010.1 for special flow divider bodies.

Cavity: VC10-4 (Variation "A"); See page 9.110.1

Cavity Tool: CT10-4XX; See page 8.600.1

Seal Kit: SK10-4X-MMM; See page 8.650.1

SYMBOLS

USAS/ISO:

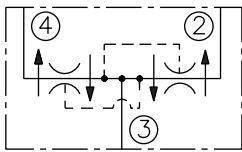

PERFORMANCE (Cartridge Only)

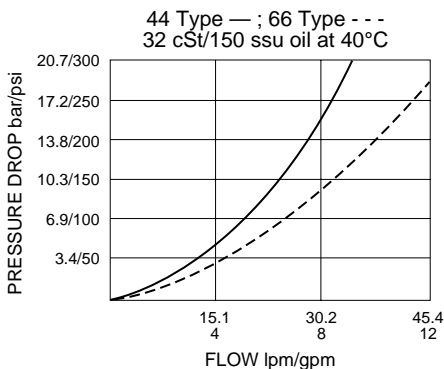

Note: This model will be superseded by the new FDxx-45 models, which incorporate the features of the FDxx-40, FDxx-41 and FDxx-42 series valves in one product. OEM's are encouraged to consider the newer, more robust and versatile FDxx-45 models for new applications:

FD50-45; see page 5.632.1

FD52-45; see page 5.634.1

FD56-45; see page 5.636.1

DIMENSIONS

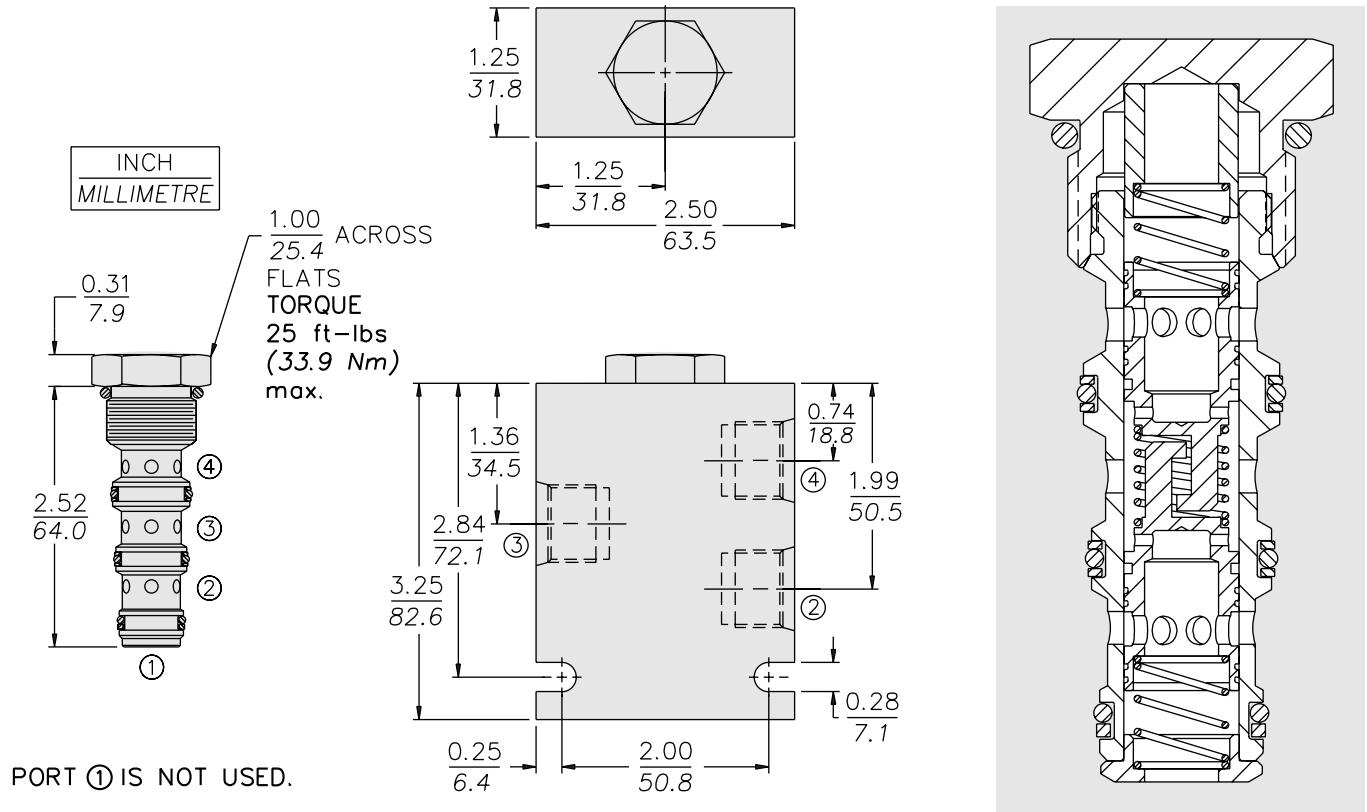

MATERIALS

Cartridge: Weight: 0.10 kg. (0.23 lbs.)
Steel with hardened work surfaces.
Zinc-plated exposed surfaces.
Buna N O-rings and polyester
elastomer back-ups standard.

Special Ported Body: Weight: 0.34 kg.
(0.75 lbs.) Anodized high-strength
6061 T6 aluminum alloy, rated to
207 bar (3000 psi). Ductile iron
bodies available; dimensions
may differ; See page 8.010.1.

TO ORDER

FD10-41 -

Special Ported Bodies

Cartridge Only	0
SAE 6 (All Ports)	6T
SAE 8 ③;	
SAE 6 ② & ④	8D
1/4 in. BSP* (All Ports)	2B
3/8 in. BSP* (All Ports)	3B
1/2 in. BSP* ③;	
3/8 in. BSP* ② & ④	5B

*BSP Body; U.K. Mfr. Only

NOTE: Standard 10-size 4-way
bodies should not be used for
flow dividers. See special flow
divider bodies, page 8.010.1

Dividing/Combining Ratio

11	50:50 rated @ 7.6 lpm (2 gpm) input
22	50:50 rated @ 15.1 lpm (4 gpm) input
33	50:50 rated @ 22.7 lpm (6 gpm) input
44	50:50 rated @ 30.3 lpm (8 gpm) input
55	50:50 rated @ 37.9 lpm (10 gpm) input
66	50:50 rated @ 45.4 lpm (12 gpm) input

Seals

- N** Buna N (Std.)
- V** Fluorocarbon

NOTE: Additional ratios and/or input flow
sizings available for OEM applications.
Consult factory.