

NV10-20 Needle Valve

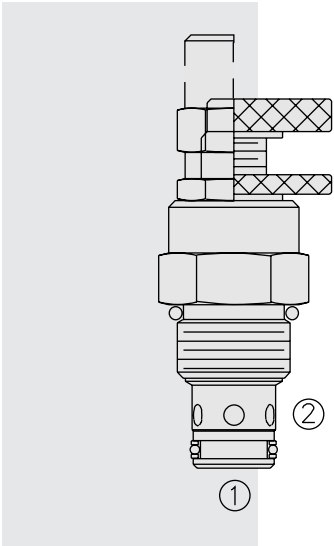

DESCRIPTION

A screw-in, cartridge-style, variable orifice, hydraulic flow restrictor valve.

OPERATION

The **NV10-20** increases its orifice value from fully closed to fully open with counterclockwise adjustment rotation.

FEATURES

- Adjustments cannot be backed out of the valve.
- Desired settings may be locked down.
- Hardened parts for long life.
- Industry common cavity.
- Aluminum knob option.
- Positive shut-off.
- Linear adjustment.

RATINGS

Operating Pressure: 240 bar (3500 psi)

Flow: 45 lpm (12 gpm) nominal at 7 bar (100 psi) at full open 3.5 turns

Internal Leakage: 0.25 cc/minute (5 drop/minute) max. at shut-off

Adjustment Torque Required: 0.56 Nm (5 inch-pounds) at 7 bar (100 psi);
5.41Nm (48 inch-pounds) at 207 bar (3000 psi)

Temperature: -40 to 120°C

Filtration: See page 9.010.1

Fluids: Mineral-based or synthetics with lubricating properties at viscosities of
7.4 to 420 cSt (50 to 2000 sus); See Temperature and Oil Viscosity, page 9.060.1

Installation: No restrictions; See page 9.020.1

Cavity: VC10-2; See page 9.110.1

Cavity Tool: CT10-2XX; See page 8.600.1

Seal Kit: SK10-2X-M; See page 8.650.1

SYMBOLS

USASI/ISO:

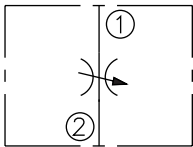

PERFORMANCE (Cartridge Only)

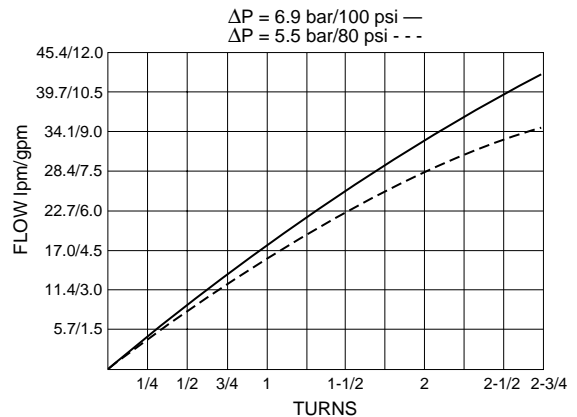
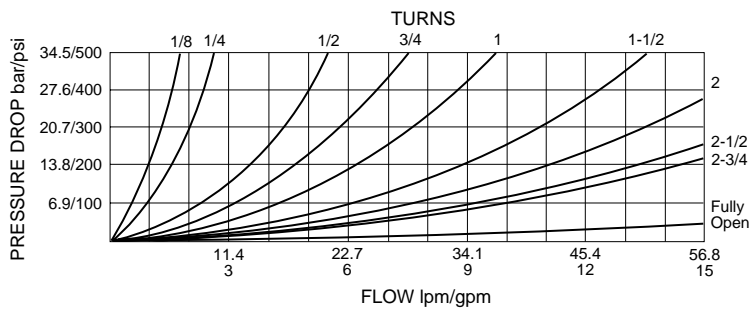

DIMENSIONS

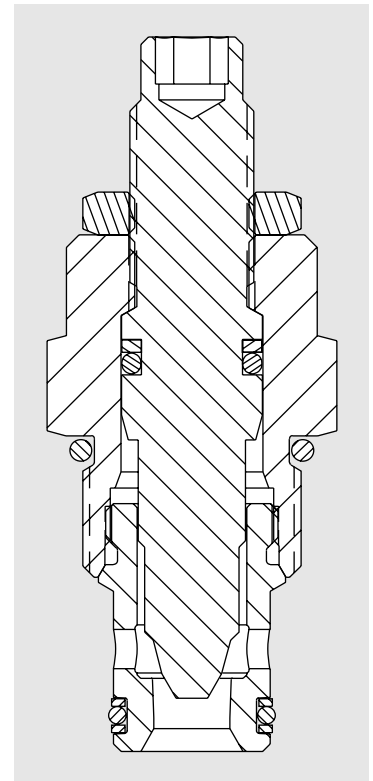
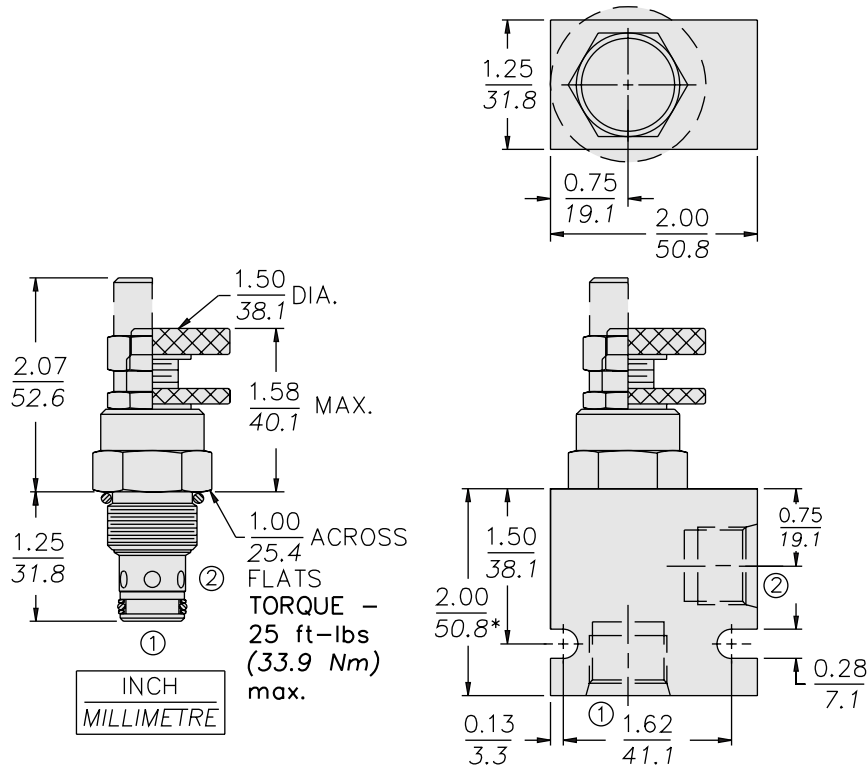

* BSP BODY - 55.9

MATERIALS

Cartridge: Weight: 0.15 kg. (0.33 lbs.)
 Steel with hardened work surfaces.
 Zinc-plated exposed surfaces.
 Buna N O-rings and polyester elastomer back-ups standard.
 Anodized aluminum knobs.

Standard Ported Body: Weight:
 0.16 kg. (0.35 lbs.) Anodized high-strength 6061 T6 aluminum alloy, rated to 207 bar (3000 psi). Ductile iron bodies available; dimensions may differ. See page 8.010.1

TO ORDER

NV10-20

Adjustment Option

- A 1/4 in. Hex Allen Head
- B 1-1/2 in. Dia. Alum. Knob
- C Option A with Cover Cap
- D Top Knob with Lock Nut
- E Top Knob Only
- L Option C with Lockwire Holes

Seals

- N Buna N (Std.)
- V Fluorocarbon

Porting

- 0 Cartridge Only
- 6T SAE 6
- 8T SAE 8
- 2B 1/4 in. BSP*
- 3B 3/8 in. BSP*
- 4B 1/2 in. BSP*

*BSP Body;
 U.K. Mfr. Only