

# DIRECTIONAL VALVES

## MP58-30 Manual, Spring Return, Pull-to-Shift

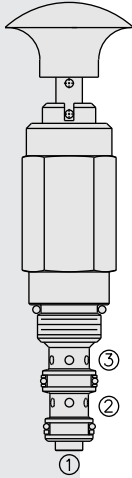

### DESCRIPTION

A 3-way, manual, pull-to-shift, spring-return, directional hydraulic cartridge valve. Series operation is prohibited due to the tank port (1) pressure rating.

### OPERATION

In its steady-state, spring-offset position, the **MP58-30** directs flow from 2 to 1, while blocking at 3.

In the actuated (pulled) position, the cartridge directs flow from 3 to 2, blocking 1. The spring chamber is vented at 1.

**Note: Pressure at port 1 will directly act on the spool and spring. Port 1 is intended to be a tank port only.**

A unique pull-and-rotate feature for holding the positive actuated position is optional. A 90° rotation is required to position at the hold slot. The valve resets to spring-return de-actuated with a slight pull and a 90° turn from the locked actuated position.

### FEATURES

- Hardened spool and cage for long life.
- Pressure to 14 bar (200 psi) on 1.
- Optional rotational lock position.
- Compact size.

### RATINGS

#### Operating Pressure:

- On 3 to 2: 345 bar (5000 psi)
- On 1 (Max.): 14 bar (200 psi)

#### Flow: See Performance Chart

**Internal Leakage:** 147 cc/minute (9 cu. in./minute) max. at 345 bar (5000 psi)

**Mechanical Pull Effort Required:** 7.7 kg. (17 lbs.) installed; 8.6 kg. (19 lbs.) to travel 3.2 mm (0.125 in.); 9.1 kg. (20 lbs.) to detent

**Temperature:** -40 to 120°C

**Filtration:** See page 9.010.1

**Fluids:** Mineral-based or synthetics with lubricating properties at viscosities of 7.4 to 420 cSt (50 to 2000 sus); See Temperature and Oil Viscosity, page 9.060.1

**Installation:** No restrictions; See page 9.020.1

**Cavity:** VC08-3; See page 9.108.1

**Cavity Tool:** CT08-3XX; See page 8.600.1

**Seal Kit:** SK08-3P-MT; See page 8.650.1

### SYMBOLS

#### USASI/ISO:

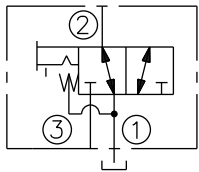

#### TRANSITION:

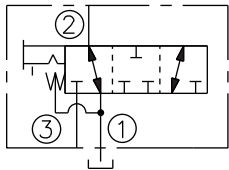

### PERFORMANCE (Cartridge Only)

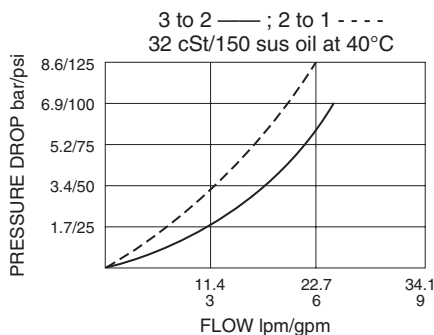

## DIMENSIONS

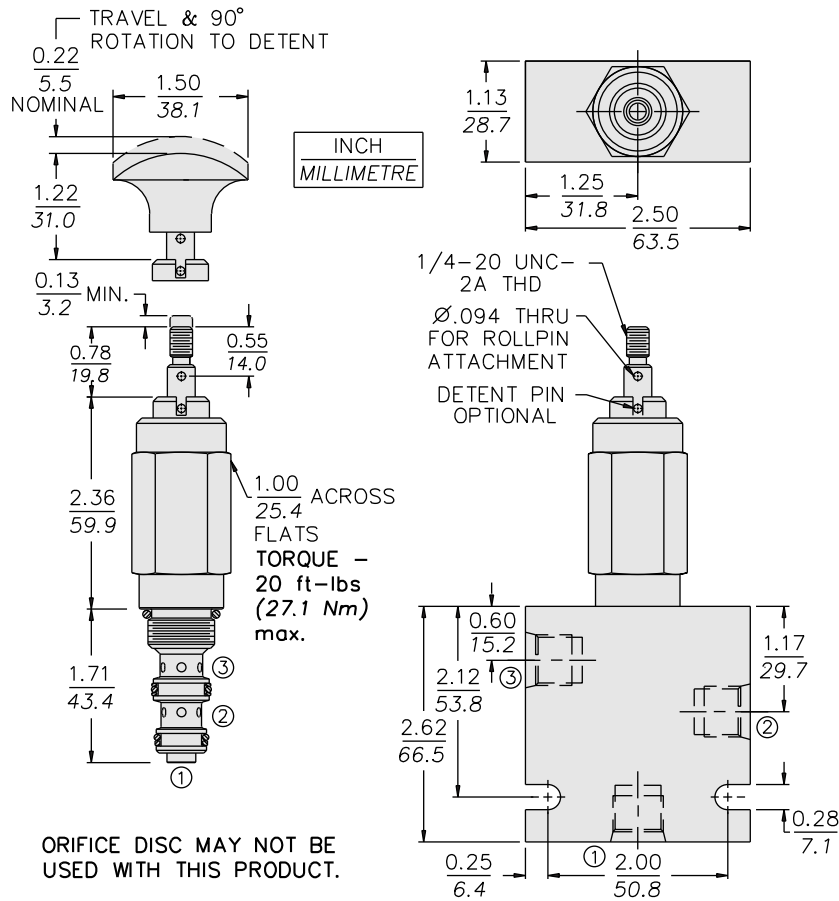

## MATERIALS

**Cartridge:** Weight: 0.23 kg. (0.50 lbs.)  
Steel with hardened work surfaces.  
Zinc-plated exposed surfaces.  
Polyurethane cast O-rings and  
Fluorocarbon back-up standard.  
Plastic knob optional.

**Standard Ported Body:** Weight:  
0.27 kg. (0.60 lbs.) Anodized  
high-strength 6061 T6 aluminum  
alloy, rated to 207 bar (3000 psi).  
Ductile iron (code D) bodies are  
required for operation over 207 bar  
(3000 psi), dimensions may differ.  
See page 8.008.1

## TO ORDER

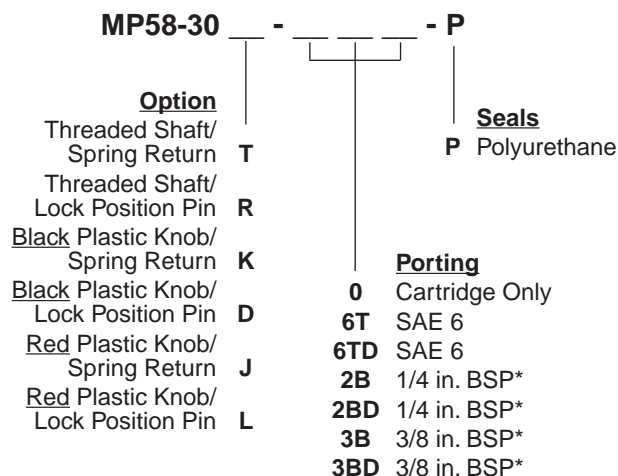

\*BSP Body;  
U.K. Mfr. Only