

DIRECTIONAL VALVES

PE12-S67H Proportional, Pilot Operated

U.S. Patent
6,554,014

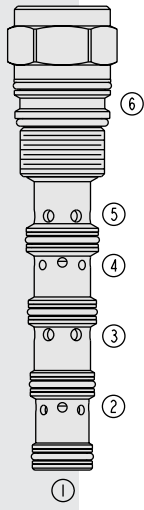

DESCRIPTION

A screw-in, cartridge-style, proportional, spring-centered, pilot-operated spool-type hydraulic directional valve.

OPERATION

When the PE12-S67H is in neutral position port ③ is blocked and ports ②, ④ and ⑤ are in communication with each other. When the remote pilot signal at ① exceeds the force of the bias spring, the spool shifts proportionally to the applied pilot pressure to allow flow from ③ to ④, through a load such as a hydraulic cylinder or motor, and from ② to ⑤ and to tank. On remote pilot signal at ⑥, the spool shifts proportionally to the applied pressure in the opposite direction, thus reversing the flow direction. **The valve's spool is symmetrical, providing meter-in and meter-out control.**

FEATURES

- Hardened spool and cage for long life.
- Excellent metering characteristics.
- Good linearity.

RATINGS

Maximum Operating Pressure: Ports ③ and ⑤: 345 bar (5000 psi)
Ports ② and ④: 240 bar (3500 psi)
Ports ① and ⑥: 27.6 bar (400 psi)

Orifice Diameter: Between ports ② and ④ and port ⑤ in neutral position: 0.030 in.

Flow: See Performance Chart

Internal Leakage: 100 ml/minute (6 cu. in./minute) at 207 bar (3000 psi)

Temperature: -40 to 120°C with standard Buna N seals

Filtration: See page 9.010.1

Fluids: Mineral-based or synthetics with lubricating properties at viscosities of 7.4 to 420 cSt (50 to 2000 sus); See Temperature and Oil Viscosity, page 9.060.1

Installation: No restrictions; See page 9.020.1

Cavity: VC12-S6; See page 9.112.1

Cavity Tool: CT12-S6; See page 8.600.1

Seal Kit: SK12-6X-BMMMM; See page 8.650.1

SYMBOLS

USASI:

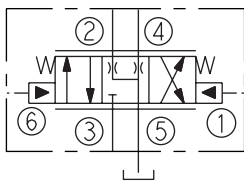

ISO:

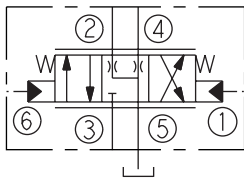

PERFORMANCE (Cartridge Only)

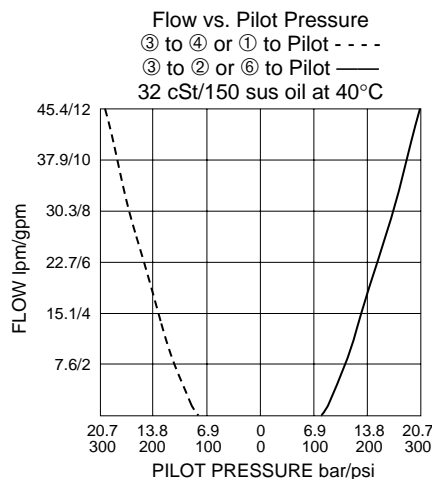
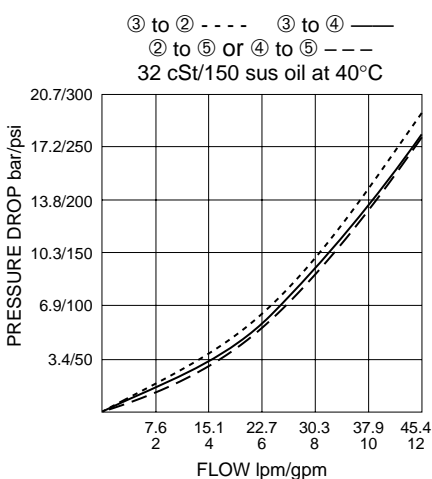

DIMENSIONS

U.S. Patent 6,554,014

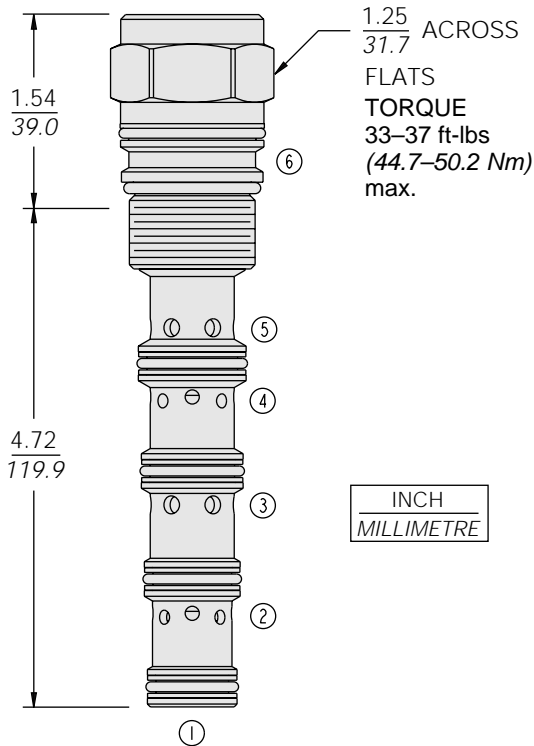

MATERIALS

Cartridge: Weight: 0.98 kg. (0.45 lbs.)
 Steel with hardened work surfaces.
 Zinc-plated exposed surfaces.
 Buna N O-rings and polyester elastomer back-ups standard.

Ported Body: Test housing available.
 See page 8.012.1

TO ORDER

PE12-S67H - -

Porting
 Cartridge Only 0

Seals

- N Buna N (Std.)
- P Polyurethane (for pressures over 240 bar/3500 psi)
- V Fluorocarbon