

HPD42-S51 HyPerformance™ Piloted 3-Way Spool

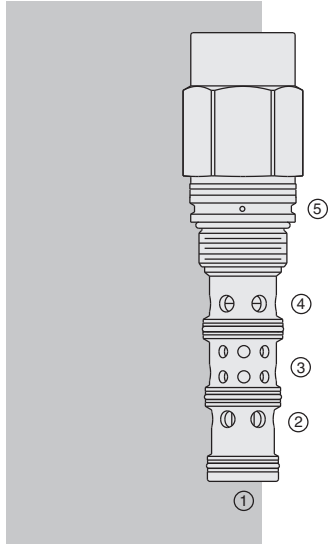

DESCRIPTION

A screw-in, cartridge-style, pilot-operated, spool-type, hydraulic directional valve for use in high pressure applications.

OPERATION

When in neutral the **HPD42-S51** allows flow between ports 2, 3 and 4. On remote pilot signal at 1, the valve's spool shifts to block all ports. The spring chamber is vented to the tank through port 5. The vented spring chamber allows the valve to be fully pressurized at ports 1, 2, 3, and 4 without affecting required pilot pressure. Pressure at port 5 will increase the required pilot pressure at a 1:1 ratio.

FEATURES

- Hardened spool and cage for long life.
- All HyPerformance™ products are tested to the rigorous standards of the NFPA specification T2.6.1.
- All HyPerformance™ valves are tested at a verification level of 90% and an assurance of 99%.

RATINGS

Operating Pressure: 350 bar (5075 psi); 10% cycle life: 420 bar (6090 psi)

Note: All HyPerformance products are tested for 900K cycles at 350 bar and 100K at 420 bar.

Proof Pressure: 690 bar (10000 psi)

Burst Pressure: 1380 bar (20000 psi)

Flow: With PPDI urethane seals up to 265 lpm (70 gpm) with no flow restrictions.

With seal option US (PPDI urethane with sealed spool between ports 1 and 2) up to 246 lpm (65 gpm) with flow restrictions from ports 2-3 and 3-4 up to 114 lpm (30 gpm).

Internal Leakage: Ports 3-4: 328 ml/minute (20 cu. in./minute) at 350 bar (5075 psi)

Ports 3-2: 492 ml/minute (30 cu. in./minute) at 350 bar (5075 psi)

Cycle Life: One million cycles.

Operating Temperature: -54 to 107°C (-65 to 225°F) with PPDI urethane seals

Filtration: See page 9.010.1

Fluids: Mineral-based or synthetics with lubricating properties at viscosities of 7.4 to 420 cSt (50 to 2000 sus); See Temperature and Oil Viscosity, page 9.060.1

Installation: No restrictions; See page 9.020.1

Cavity: HVC42-S5; See page 9.142.1

Cavity Tool: HCT42-5XX; See page 8.600.1

Seal Kit: HSK42-S5U-0000 (Urethane); See page 8.650.1

ISO SYMBOL

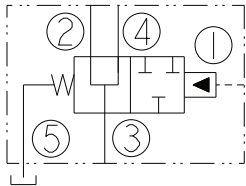

PERFORMANCE (Cartridge Only)

Pressure Drop vs. Flow
Neutral; Cartridge Only
3 to 2 - - - -; 3 to 4 ———
3 to 2 and 4 - - - - -
32 cSt/150 sus oil at 40°C

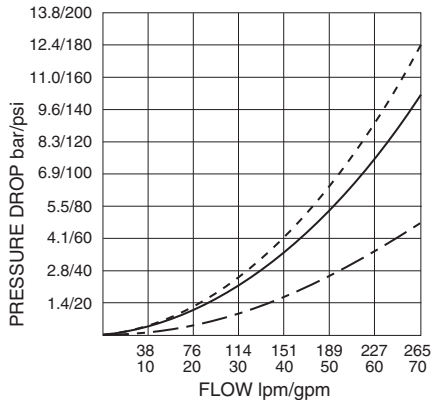

DIMENSIONS

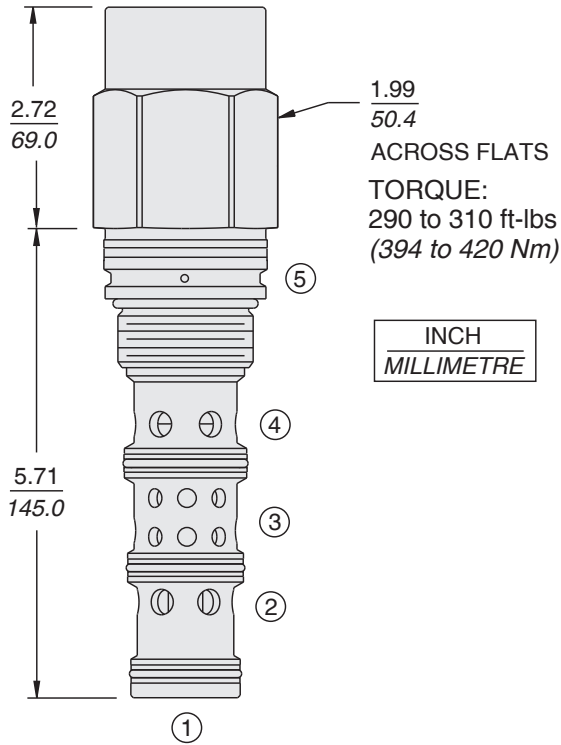

ORIFICE DISC CANNOT BE USED WITH THIS PRODUCT due to HyPerformance™ Cavity.

MATERIALS

Cartridge: Weight: 1.9 kg. (4.2 lbs.)
 Steel with hardened work surfaces.
 Zinc-plated exposed surfaces.
 PPDI Urethane seals and no back-up rings standard.

Ported Body: Weight: 14.0 kg (30.90 lbs)
 HyPerformance™ ductile iron (code 'D') standard. Rated to 345 bar (5000 psi).
 See page 8.042.1.

TO ORDER

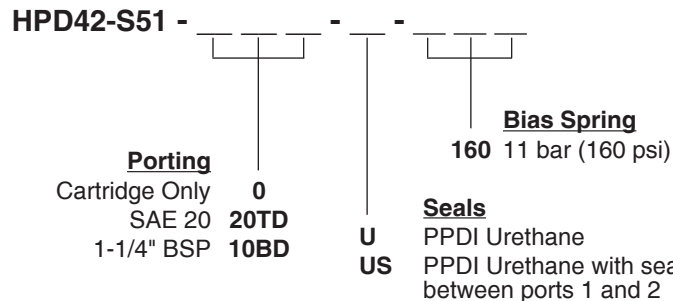

Note: PPDI Urethane seals are recommended for pressures over 241 bar (3500 psi).

Note: Consult factory for additional seal options.