

SP10-21 Poppet, 2-Way, Normally Open

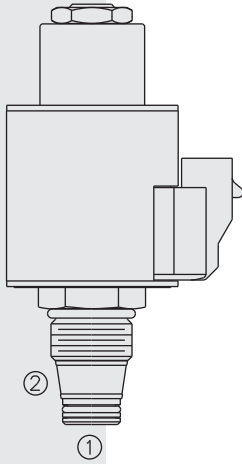

DESCRIPTION

A proportional solenoid-operated, 2-way, poppet-type, normally open, screw-in hydraulic cartridge valve for low-leakage blocking and load-holding applications and for starting or stopping a load or a pump system..

OPERATION

When de-energized, the **SP10-21** allows flow from 2 to 1. When the valve is partially energized, the valve begins to throttle the flow from 2 to 1. When fully energized, the poppet closes on the seat, blocking flow from 2 to 1. Flow from 1 to 2 will occur when hydraulic pressure exceeds the solenoid force.

Note: If low voltage is expected on the machine, 12 or 24 volt systems will require the use of 10 volt or 20 volt coils respectively. See “SP Valves and Coil Operating Parameters,” page 2.002.1.

FEATURES

- Industry-common cavity.
- Efficient wet-armature construction.
- Continuous-duty rated coils.
- Optional waterproof E-Coils rated up to IP69K.

RATINGS

Operating Pressure: 250 bar (3625 psi)

Operating Voltage: See Performance Chart

Minimum Operating Dither/Pulse Frequency: 70 Hz

Flow: 0 to 60.6 lpm (0 to 16 gpm)

Max. Internal Leakage: 5 drops per minute at 207 bar (3000 psi)

Temperature: -40 to 120°C with standard Buna seals

Filtration: See page 9.010.1

Fluids: Mineral-based or synthetics with lubricating properties at viscosities of 7.4 to 420 cSt (50 to 2000 sus); See Temperature and Oil Viscosity, page 9.060.1

Installation: No Restrictions. See page 9.020.1

Cavity: VC10-2; See page 9.110.1; **Cavity Tool:** CT10-2XX; See page 8.600.1

Seal Kit: SK10-2X-T; See page 8.650.1

Coil Nut: Part No. 7004400

SYMBOL

USAS/ISO:

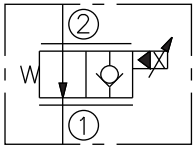

PERFORMANCE

Note: Electronic Controller is required to ramp current.

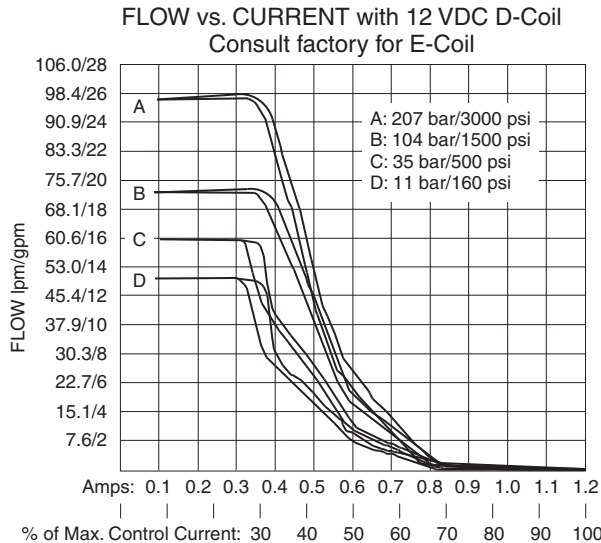
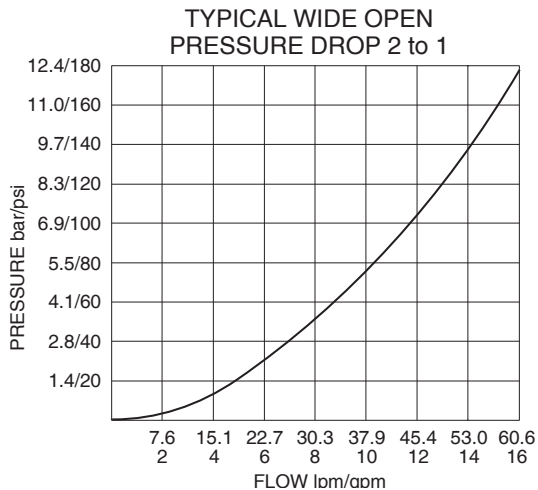

Performance charts continued on next page.

PERFORMANCE (cont'd.)

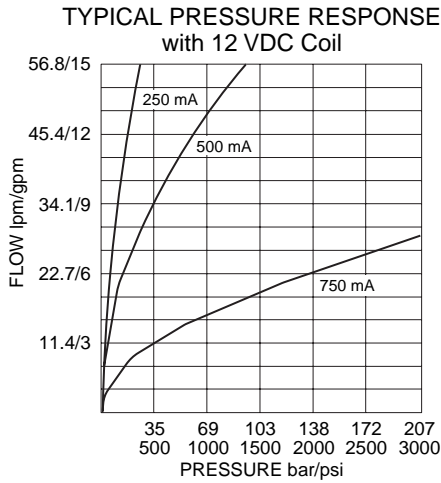

Recommended Electronic Controllers:
See page 2.001.1 or our Electronics catalog.

DIMENSIONS

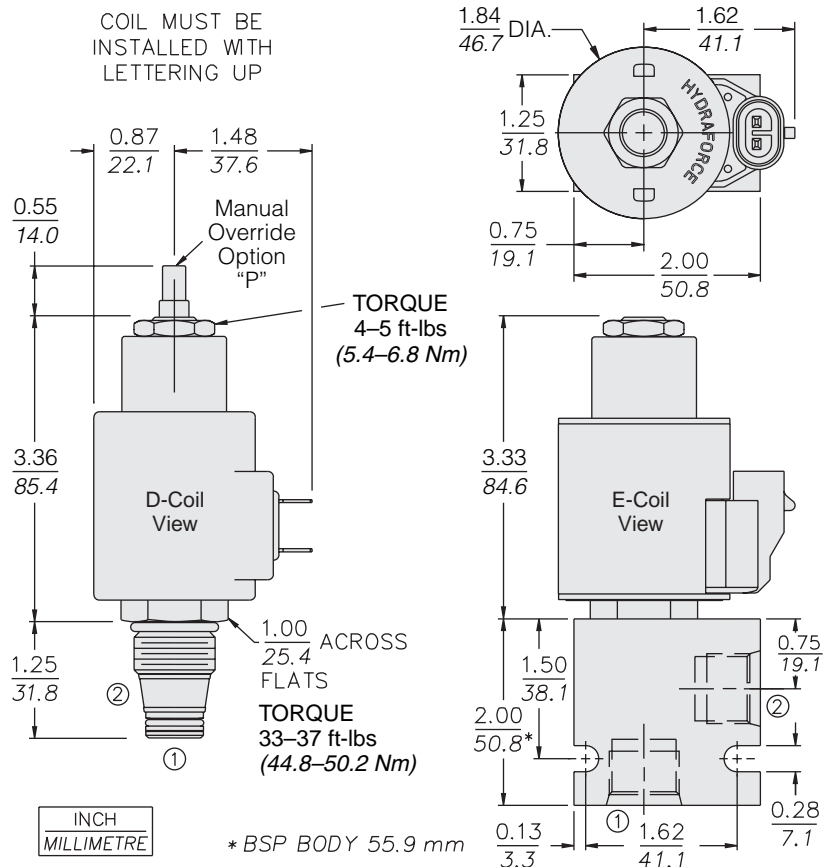

MATERIALS

Cartridge: Weight: 0.17 kg. (0.37 lbs.) Steel with hardened work surfaces. Zinc-plated exposed surfaces Buna N O-rings and back-ups standard.

Standard Ported Body: Weight: 0.16 kg. (0.35 lbs.) Anodized high-strength 6061 T6 aluminum alloy, rated to 207 bar (3000 psi). Ductile iron bodies available; dimensions may differ. See page 8.010.1.

Standard D-Coil: Weight: 0.27 kg. (0.60 lbs.) Unitized thermoplastic encapsulated, Class H high temperature magnetwire. See page 3.200.1

E-Coil: Weight: 0.41 kg. (0.9 lbs.) Perfect wound, fully encapsulated with rugged external metal shell. Rated up to IP69K with integral connectors. See page 3.400.1

TO ORDER

