

SOLENOID VALVES

SV10-47B Spool, 4-Way, 3-Position, Open Center

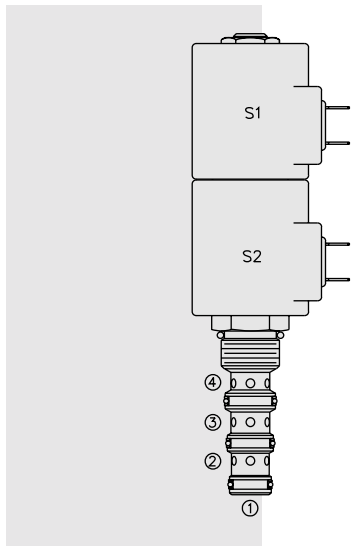

DESCRIPTION

A solenoid-operated, 4-way, 3-position, direct-acting, spool-type, open center, screw-in hydraulic cartridge valve.

OPERATION

When de-energized, **SV10-47B** cylinder ports are open and common to ③ and ①. When coil #1 is energized, flow is allowed from ③ to ④, and from ② to ①. When coil #2 is energized, flow is allowed from ③ to ②, and from ④ to ①.

In circuits where work port flows are unequal due to cylinder ratios, the higher return flow should be directed to port ②.

While ① may be fully pressurized, it is not intended for use as the valve's inlet.

Operation of Manual Override Option: To override, push the knurled button to activate the coil #2 (S2) function, or pull the knob to activate the coil #1 (S1) function.

FEATURES

- Continuous-duty rated solenoid.
- Hardened precision spool and cage for long life.
- Optional coil voltages and terminations.
- Manual override option.
- Optional waterproof E-Coils rated up to IP69K.
- Efficient wet-armature construction.
- All ports may be fully pressurized.
- Cartridges are voltage interchangeable.
- Unitized, molded coil design.
- Industry common cavity.

RATINGS

Operating Pressure: 240 bar (3500 psi)

Proof Pressure: 390 bar (5700 psi)

Flow: 22.7 lpm (6 gpm) max.

Internal Leakage: 328 cc/minute (20 cu. in./minute) max. at 207 bar (3000 psi)

Temperature: -40 to 120°C with standard Buna seals

Coil Duty Rating: Continuous from 85% to 115% of nominal voltage

Response Time: First indication of change of state with 100% voltage supplied at 80% of nominal flow rating: Energized: 30 msec.; De-energized: 10 msec.

Initial Coil Current Draw at 20°C: Standard Coil: 1.67 amps at 12 VDC; 0.18 amps at 115 VAC (full wave rectified). E-Coil: 2.0 amps at 12 VDC; 1.0 amps at 24 VDC

Minimum Pull-in Voltage: 85% of nominal at 207 bar (3000 psi)

Filtration: See page 9.010.1

Fluids: Mineral-based or synthetics with lubricating properties at viscosities of 7.4 to 420 cSt (50 to 2000 ssu)

Installation: No restrictions; See page 9.020.1

Cavity: VC10-4; See page 9.110.1

Cavity Tool: CT10-4XX; See page 8.600.1

Seal Kit: SK10-4X-MMM; See page 8.650.1

Coil Nut: Part No. 7004400; **Manual Override Coil Nut:** Part No. 4528180

Coil Spacer: Part No. 4539700

For E-coils manufactured prior to 1-1-04, see page 3.400.1 for coil nut & spacer info.

SYMBOLS

USASI:

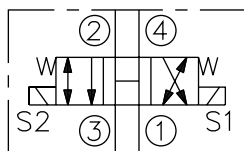

ISO:

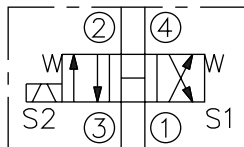

PERFORMANCE (Cartridge Only)

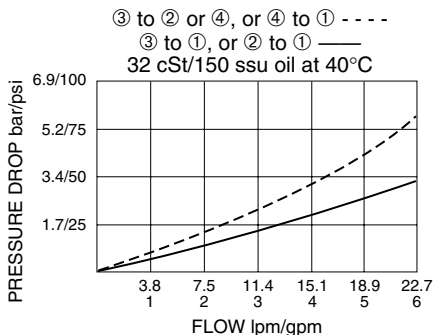

SV10-47B

DIMENSIONS

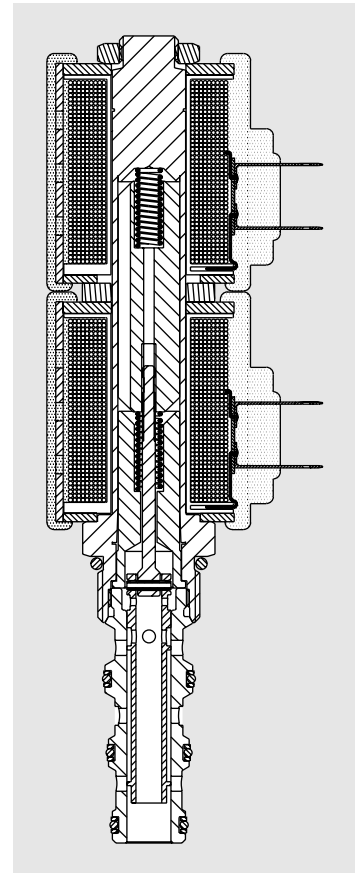
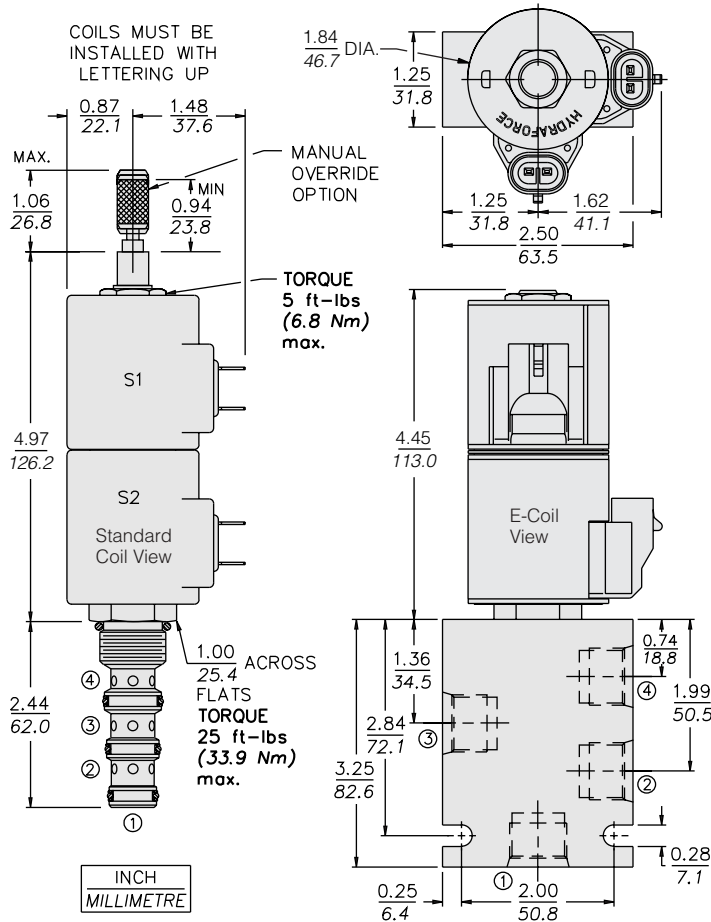

MATERIALS

Cartridge: Weight: 0.30 kg. (0.65 lbs.); Steel with hardened work surfaces. Zinc-plated exposed surfaces. Buna N O-rings and polyester elastomer back-up standard.

Standard Ported Body: Weight: 0.36 kg. (0.80 lbs.); Anodized high-strength 6061 T6 aluminum alloy, rated to 240 bar (3500 psi); See page 8.010.1. Ductile iron and steel bodies available; dimensions may differ; consult factory.

Standard Coils: Weight each: 0.27 kg. (0.60 lbs.); Unitized thermoplastic encapsulated, Class H high temperature magnetwire; See page 3.200.1.

E-Coils: Weight each: 0.41 kg. (0.9 lbs.); Fully encapsulated with rugged external metal shell; Rated up to IP69K with integral connectors; **See page 3.400.1 for E-Coil retrofit applications.**

TO ORDER

SV10-47B

Option	Voltage Std. Coil	Termination (VDC) Std. Coil
None (Blank)	0 Less Coil**	DS Dual Spades
Manual Override M	10 10 VDC [†]	DG DIN 43650
Manual Override T	12 12 VDC	DL Leadwires (2)
For Manual Override options see page 1.001.1	24 24 VDC	DL/W Leads w/Weatherpak® Connectors
	36 36 VDC	DR Deutsch DT04-2P
	48 48 VDC	Termination (VAC) Std. Coil
Porting	24 24 VAC	AG DIN 43650
Cartridge Only 0	115 115 VAC	AP 1/2 in. Conduit
SAE 6 6T	230 230 VAC	Termination (VDC) E-Coil
SAE 8 8T	**Includes coil nut and coil spacer	ER Deutsch DT04-2P (IP69K Rated)
1/4 in. BSP* 2B	[†] DS, DW or DL terminations only	EY Metri-Pack® 150 (IP69K Rated)
3/8 in. BSP* 3B	E-Coil	
*BSP Body; U.K. Mfr. Only	10 10 VDC	
Seals	12 12 VDC	
Buna N (Std.) N	20 20 VDC	
Fluorocarbon V	24 24 VDC	

Coils with internal diode are available. Consult factory.