

# SOLENOID VALVES

## SV08-47A Spool, 4-Way, 3-Position, Tandem Center

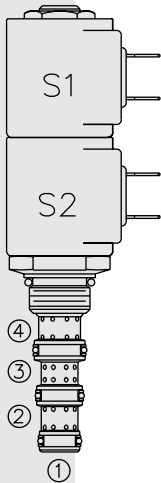

### DESCRIPTION

A solenoid-operated, 4-way, 3-position, direct-acting, spool-type, tandem center, screw-in hydraulic cartridge valve.

### OPERATION

When de-energized, the **SV08-47A** blocks cylinder ports, while allowing flow from ③ to ①. When coil #1 is energized, flow is allowed from ③ to ②, and from ④ to ①. When coil #2 is energized, flow is allowed from ③ to ④, and from ② to ①.

In circuits where work port flows are unequal due to cylinder ratios, the higher return flow should be directed to port ②.

**While ① may be fully pressurized, it is not intended for use as the valve's inlet.**

Operation of Manual Override Option: To override, push the knurled knob to activate the coil #2 (S2) function; pull the knob to activate the coil #1 (S1) function.

### FEATURES

- Continuous-duty rated solenoid.
- Hardened precision spool and cage for long life.
- Optional coil voltages and terminations.
- Efficient wet-armature construction.
- All ports may be fully pressurized.
- Cartridges are voltage interchangeable.
- Unitized, molded coil design.
- Manual override option.
- Optional waterproof E-Coils rated up to IP69K.

### RATINGS

**Operating Pressure:** 210 bar (3000 psi)

**Flow:** 11.4 lpm (3.0 gpm) max.

**Internal Leakage:** 278 cc/minute (17 cu. in./minute) max. at 207 bar (3000 psi)

**Temperature:** -40 to 120°C with standard Buna seals

**Coil Duty Rating:** Continuous from 85% to 115% of nominal voltage

**Initial Coil Current Draw at 20°C:** Standard Coil: 1.2 amps at 12 VDC; 0.13 amps at 115 VAC (full wave rectified). E-Coil: 1.4 amps at 12 VDC; 0.7 amps at 24 VDC

**Minimum Pull-in Voltage:** 85% of nominal at 207 bar (3000 psi)

**Filtration:** See page 9.010.1

**Fluids:** Mineral-based or synthetics with lubricating properties at viscosities of 7.4 to 420 cSt (50 to 2000 ssu). For high viscosity applications, consult factory.

**Installation:** No restrictions; See page 9.020.1

**Cavity:** VC08-4; See page 9.108.1

**Cavity Tool:** CT08-4XX; See page 8.600.1

**Seal Kit:** SK08-4X-MMM; See page 8.650.1

**Coil Nut:** Part No. 7004400; **Manual Override Coil Nut:** Part No. 4528180;

**Coil Spacer:** Part No. 4534720

For E-coils manufactured prior to 1-1-04, see page 3.400.1 for coil nut & spacer info.

### SYMBOLS

#### USASI:

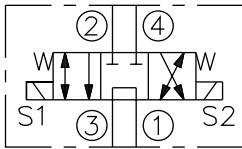

#### ISO:

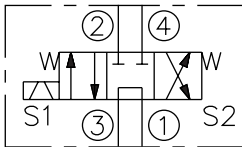

### PERFORMANCE (Cartridge Only)

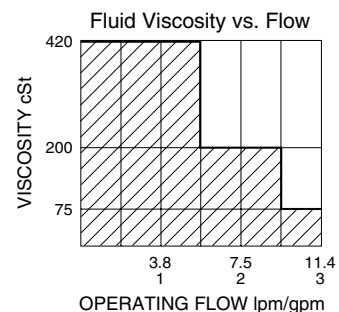
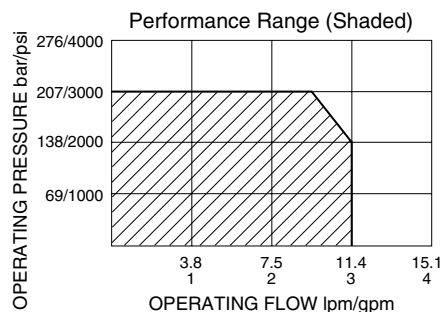
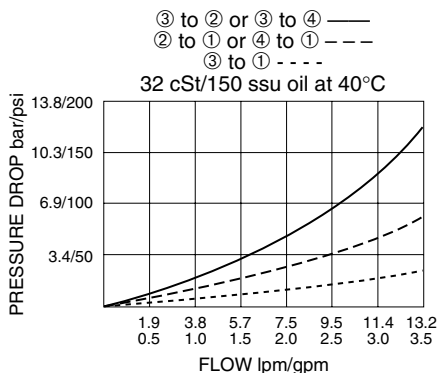

**DIMENSIONS**

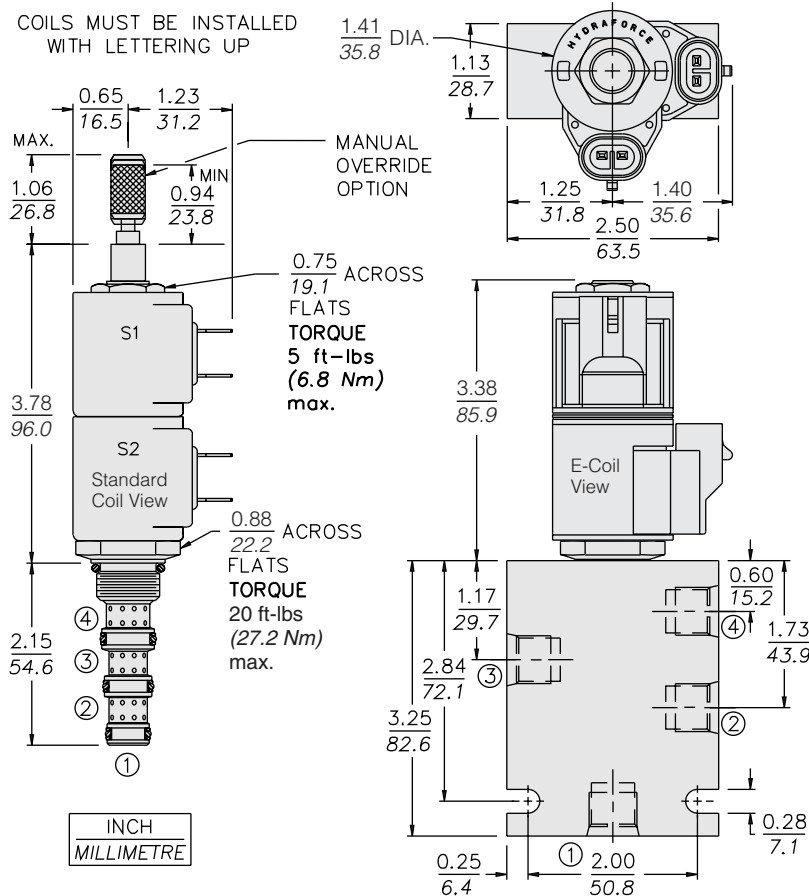

**MATERIALS**

**Cartridge:** Weight: 0.13 kg. (0.28 lbs.); Steel with hardened work surfaces. Zinc-plated exposed surfaces; Buna N O-rings and polyester elastomer back-ups standard.

**Standard Ported Body:** Weight: 0.27 kg. (0.60 lbs.); Anodized high-strength 6061 T6 aluminum alloy, rated to 240 bar (3500 psi); See page 8.008.1. Ductile iron and steel bodies available; dimensions may differ; consult factory.

**Standard Coil:** Weight each: 0.11 kg. (0.25 lbs.); Unitized thermoplastic encapsulated, Class H high temperature magnetwire; See page 3.200.1.

**E-Coil:** Weight each: 0.14 kg. (0.3 lbs.); Fully encapsulated with rugged external metal shell; Rated up to IP69K with integral connectors; **See page 3.400.1 for E-Coil retrofit applications.**

**TO ORDER**

**SV08-47A**

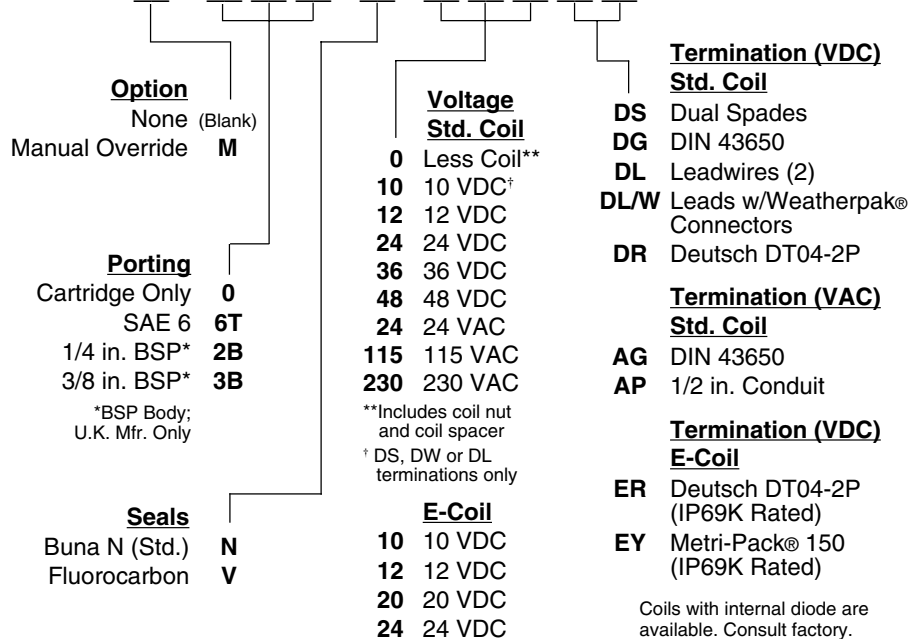

Coils with internal diode are available. Consult factory.