

SOLENOID VALVES

SV12-34 Spool, 3-Way

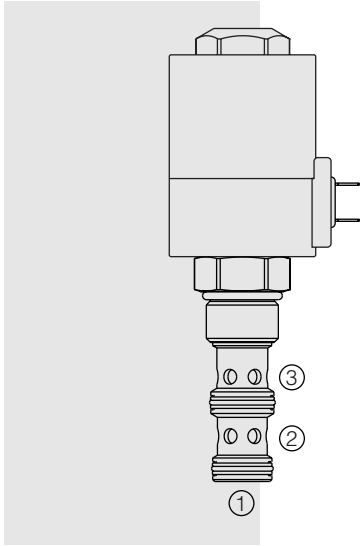

DESCRIPTION

A solenoid-operated, 3-way, direct-acting spool-type, screw-in hydraulic cartridge valve.

OPERATION

When de-energized, the **SV12-34** allows flow between ② and ①, while blocking flow at ③. When energized, the spool shifts to allow flow between ② and ③, while blocking flow at ①.

FEATURES

- Continuous-duty rated solenoid.
- Hardened spool and cage for long life.
- Optional coil voltages and terminations.
- All ports may be fully pressurized.
- Heavy-duty waterproof E-Coils rated up to IP69K.

RATINGS

Operating Pressure: 240 bar (3500 psi) max.

Flow: See Performance Chart

Leakage: 410 cc/minute (25 cu. in./minute) at 240 bar (3500 psi)

Temperature: -40 to 120°C with Buna N seals

Coil Duty Rating: See Chart

Response Time: Pull-In: 100 msec; Drop-Out: 100 msec

Initial Coil Current Draw at 20°C: 2.8 amps at 12 VDC

Filtration: See page 9.010.1

Fluids: Mineral-based or synthetics with lubricating properties at viscosities of 7.4 to 420 cSt (50 to 2000 ssu)

Installation: No restrictions; See page 9.020.1

Cavity: VC12-3; See page 9.112.1

Cavity Tool: CT12-3XX; See page 8.600.1

Seal Kit: SK12-3X-MM; See page 8.650.1

E-Coil Nut: Part No. 7085180

SYMBOLS

USAS/ISO:

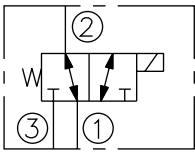

PERFORMANCE (Cartridge Only)

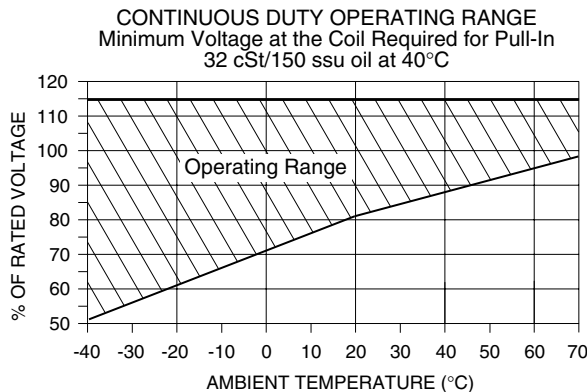
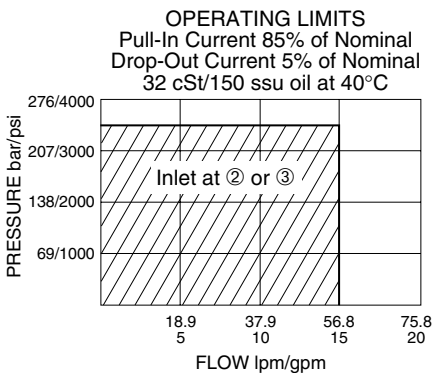
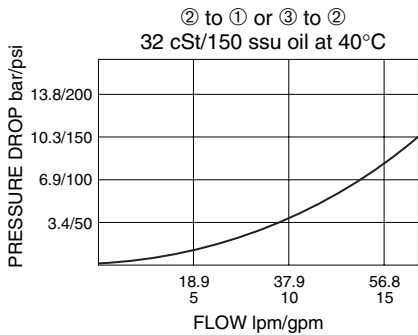

DIMENSIONS

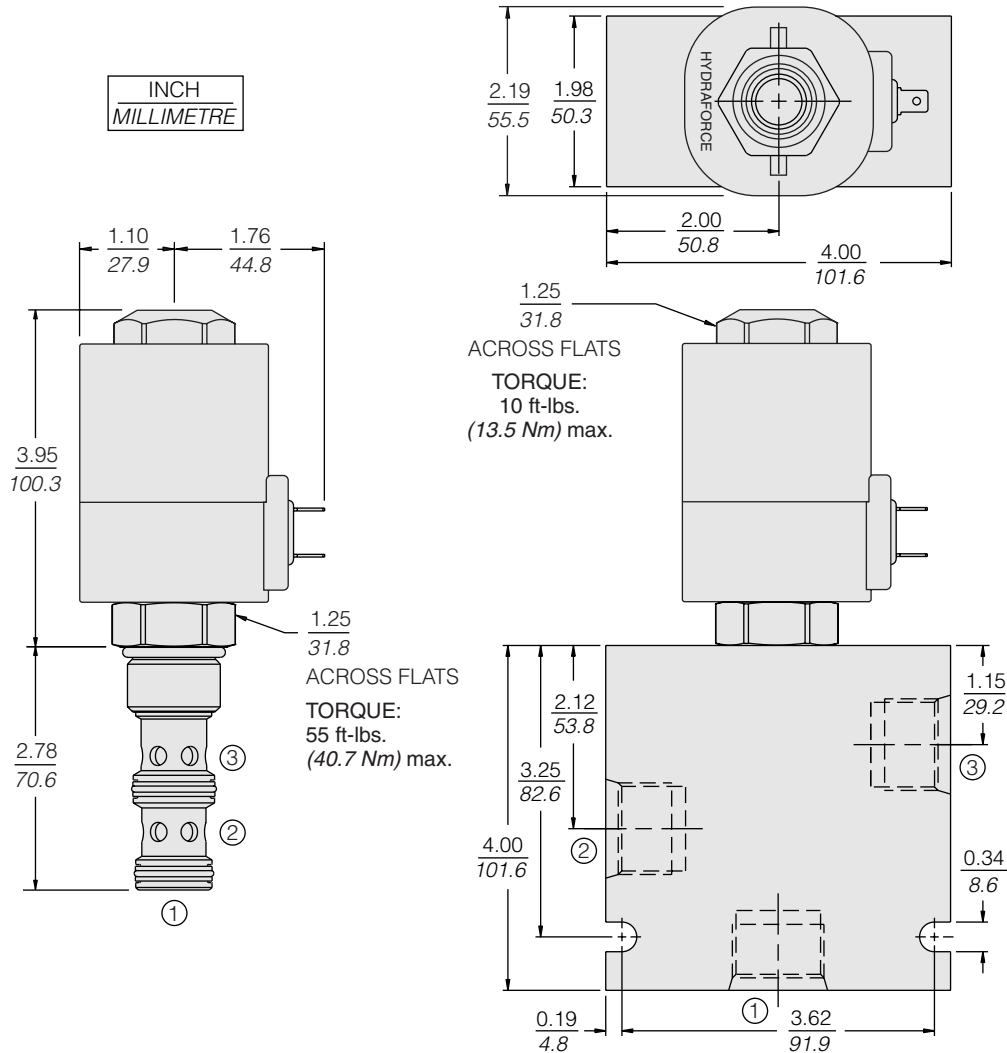

MATERIALS

Cartridge: Weight: 0.29 kg. (0.65 lbs.); Steel with hardened work surfaces. Zinc-plated exposed surfaces; Buna N O-rings and TFE back-ups standard.

Standard Ported Body: Weight: 0.98 kg. (2.15 lbs.); Anodized high-strength 6061 T6 aluminum alloy, rated to 240 bar (3500 psi); See page 8.012.1. Ductile iron and steel bodies available; dimensions may differ; consult factory.

E-Coil: Weight: 1.36 kg. (3.0 lbs.); Fully encapsulated with rugged external metal shell; Rated up to IP69K with integral connectors; See page 3.400.1.

TO ORDER

SV12-34

Option
None (Blank)
Manual Override without Knob **P**
Manual Override with Knob **K**

Porting
Cartridge Only **0**
SAE 8 **8T**
SAE 10 **10T**
SAE 12 **12T**
1/2 in. BSP* **4B**
3/4 in. BSP* **6B**

Voltage
0 Less Coil
12 12 VDC
24 24 VDC
36 36 VDC
48 48 VDC

Seals
N Buna N (Std.)
V Fluorocarbon

Terminations (VDC)
EL Leadwires (2), IP65 Rated
ES Dual Spades, IP65 Rated
EG DIN 43650, IP65 Rated
EW Leads w/Weather-Pack® Connector, IP65 Rated
EY Metri-Pack® 150 Connector, IP69K Rated

Coils with internal diode are available. Consult factory.

Other coil voltages may be available for OEM applications. Consult factory.

*BSP Body; U.K. Mfrs. Only