

# SOLENOID VALVES

## SV08-31 Spool, 3-Way

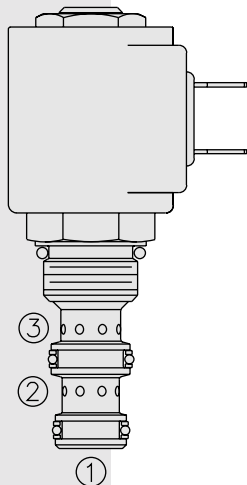

### DESCRIPTION

A solenoid-operated, 3-way, direct-acting, spool-type, screw-in hydraulic cartridge valve.

### OPERATION

When de-energized, the **SV08-31** allows flow from ② to ①, while blocking flow at ③.

When energized, the valve's spool shifts to open from ① to ③, while blocking at ②.

**Operation of Manual Override Option:** To override, push button in and twist counterclockwise 180°. The internal spring will push the button out. In this position, the valve may be only partially shifted. To assure full override shift, pull the button out to its fullest extension and hold it in this position.

To return to normal valve function, push button in, twist clockwise 180° and release. Override will be detented in this position.

### FEATURES

- Continuous-duty rated solenoid.
- Hardened precision spool and cage for long life.
- Optional coil voltages and terminations.
- Efficient wet-armature construction.
- Cartridges are voltage interchangeable.
- All ports may be fully pressurized.
- Manual override option.
- Optional waterproof E-Coils rated up to IP69K.
- Unitized molded coil design.
- Compact size.

### SYMBOLS

#### USAS/ISO:

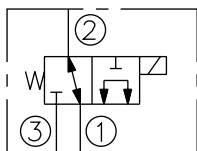

### PERFORMANCE (Cartridge Only)

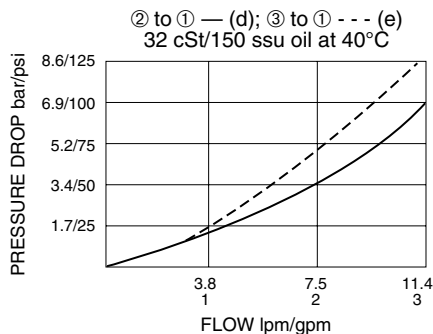

### RATINGS

**Operating Pressure:** 207 bar (3000 psi)

**Flow:** See Performance Chart; Note: Under certain operating conditions this valve may be rated for higher flow. Consult factory.

**Internal Leakage:** 82 cc/minute (5 cu. in./minute) max. at 207 bar (3000 psi)

**Temperature:** -40 to 120°C with standard Buna seals

**Coil Duty Rating:** Continuous from 85% to 115% of nominal voltage

**Response Time:** First indication of change of state with 100% voltage supplied at 80% of nominal flow rating: Energized: 30 msec.; De-energized: 25 msec.

**Initial Coil Current Draw at 20°C:** Standard Coil: 1.2 amps at 12 VDC; 0.13 amps at 115 VAC (full wave rectified). E-Coil: 1.4 amps at 12 VDC; 0.7 amps at 24 VDC

**Minimum Pull-in Voltage:** 85% of nominal at 207 bar (3000 psi)

**Filtration:** See page 9.010.1

**Fluids:** Mineral-based or synthetics with lubricating properties at viscosities of 7.4 to 420 cSt (50 to 2000 ssu)

**Installation:** No restrictions; See page 9.020.1

**Cavity:** VC08-3; See page 9.108.1

**Cavity Tool:** CT08-3XX; See page 8.600.1

**Seal Kit:** SK08-3X-MM; See page 8.650.1

**Coil Nut:** Part No. 7004400;

For E-coils manufactured prior to 1-1-04, see page 3.400.1 for coil nut info.

## DIMENSIONS

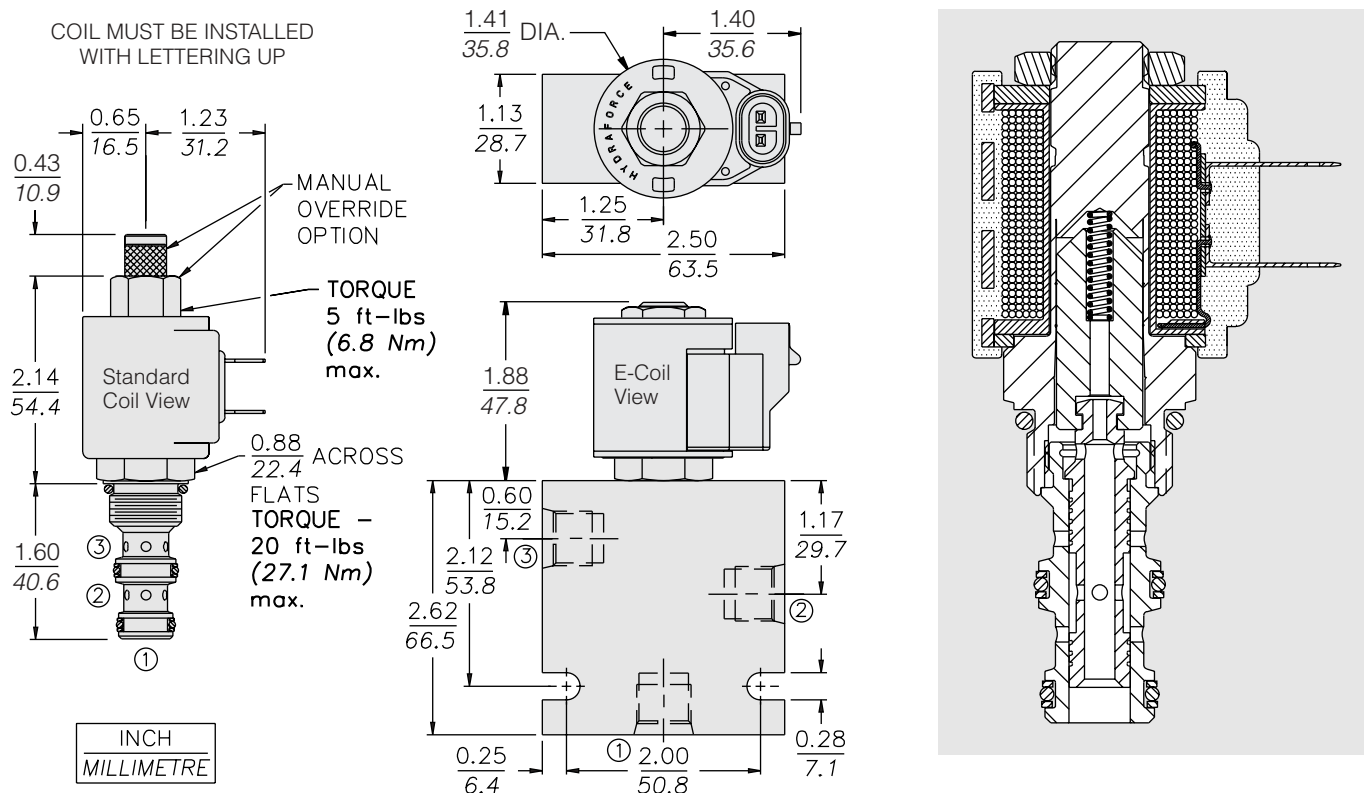

## MATERIALS

**Cartridge:** Weight: 0.13 kg. (0.28 lbs.); Steel with hardened work surfaces. Zinc-plated exposed surfaces; Buna N O-rings and back-ups standard.

**Standard Ported Body:** Weight: 0.27 kg. (0.60 lbs.); Anodized high-strength 6061 T6 aluminum alloy, rated to 240 bar (3500 psi); See page 8.008.1. Ductile iron and steel bodies available; dimensions may differ; consult factory.

**Standard Coil:** Weight: 0.11 kg. (0.25 lbs.); Unitized thermoplastic encapsulated, Class H high temperature magnetwire; See page 3.200.1.

**E-Coil:** Weight: 0.14 kg. (0.3 lbs.); Fully encapsulated with rugged external metal shell; Rated up to IP69K with integral connectors; **Note: See page 3.400.1 for all E-Coil retrofit applications.**

## TO ORDER

<b>SV08-31</b>		-	-	-	-	-	-
<b>Option</b>	None (Blank)						
Manual Override	<b>M</b>						
<b>Porting</b>							
Cartridge Only	<b>0</b>						
SAE 6	<b>6T</b>						
1/4 in. BSP*	<b>2B</b>						
*BSP Body; U.K. Mfr. Only							
<b>Seals</b>							
Buna N (Std.)	<b>N</b>						
Fluorocarbon	<b>V</b>						
<b>Voltage Std. Coil</b>							
	<b>0</b>	Less Coil**					
	<b>10</b>	10 VDC†					
	<b>12</b>	12 VDC					
	<b>24</b>	24 VDC					
	<b>36</b>	36 VDC					
	<b>48</b>	48 VDC					
	<b>24</b>	24 VAC					
	<b>115</b>	115 VAC					
	<b>230</b>	230 VAC					
**Includes Std. Coil Nut							
† DS, DW or DL terminations only							
<b>E-Coil</b>							
	<b>10</b>	10 VDC					
	<b>12</b>	12 VDC					
	<b>20</b>	20 VDC					
	<b>24</b>	24 VDC					
<b>Termination (VDC) Std. Coil</b>							
<b>DS</b>	Dual Spades						
<b>DG</b>	DIN 43650						
<b>DL</b>	Leadwires (2)						
<b>DL/W</b>	Leads w/Weatherpak® Connectors						
<b>DR</b>	Deutsch DT04-2P						
<b>Termination (VAC) Std. Coil</b>							
<b>AG</b>	DIN 43650						
<b>AP</b>	1/2 in. Conduit						
<b>Termination (VDC) E-Coil</b>							
<b>ER</b>	Deutsch DT04-2P (IP69K Rated)						
<b>EY</b>	Metri-Pack® 150 (IP69K Rated)						

Coils with internal diode are available. Consult factory.