

# SOLENOID VALVES

## SV07-31 Spool, 3-Way

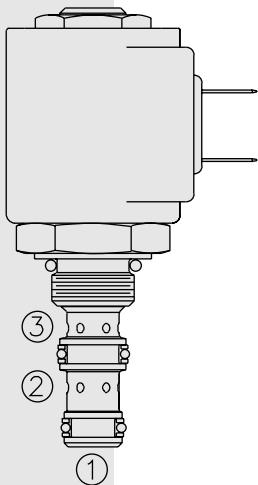

### DESCRIPTION

A solenoid-operated, 3-way, direct-acting, spool-type, screw-in hydraulic cartridge valve.

### OPERATION

When de-energized, the **SV07-31** allows flow from ② to ①, while blocking flow at ③. When energized, the cartridge's spool shifts to open from ① to ③, while blocking at ②.

### FEATURES

- Continuous-duty rated solenoid.
- Hardened precision spool and cage for long life.
- Optional coil voltages and terminations.
- Efficient wet-armature construction.
- Cartridges are voltage interchangeable.
- All ports may be fully pressurized.
- Optional waterproof E-Coils rated up to IP69K.
- Unitized molded coil design.
- Compact size.

### RATINGS

**Operating Pressure:** 207 bar (3000 psi)

**Flow:** See Performance Chart

**Internal Leakage:** 41 cc/minute (2.5 cu. in./minute) max. at 207 bar (3000 psi)

**Temperature:** -40 to 120°C with standard Buna seals

**Coil Duty Rating:** Continuous from 85% to 115% of nominal voltage

**Initial Coil Current Draw at 20°C:** Standard Coil: 1.2 amps at 12 VDC; 0.13 amps at 115 VAC (full wave rectified). E-Coil: 1.4 amps at 12 VDC; 0.7 amps at 24 VDC

**Minimum Pull-in Voltage:** 85% of nominal at 207 bar (3000 psi)

**Filtration:** See page 9.010.1

**Fluids:** Mineral-based or synthetics with lubricating properties at viscosities of 7.4 to 420 cSt (50 to 2000 ssu)

**Installation:** No restrictions; See page 9.020.1

**Cavity:** VC07-3; See page 9.107.1

**Cavity Tool:** CT07-3XX; See page 8.600.1

**Seal Kit:** SK07-3X-MM; See page 8.650.1

**Standard Coil Nut:** Part No. 7004400;

For E-coils manufactured prior to 1-1-04, see page 3.400.1 for coil nut info.

### SYMBOLS

#### USAS/ISO:

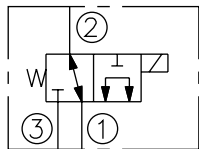

### PERFORMANCE (Cartridge Only)

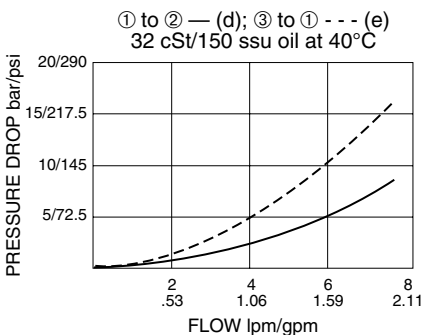

**DIMENSIONS**

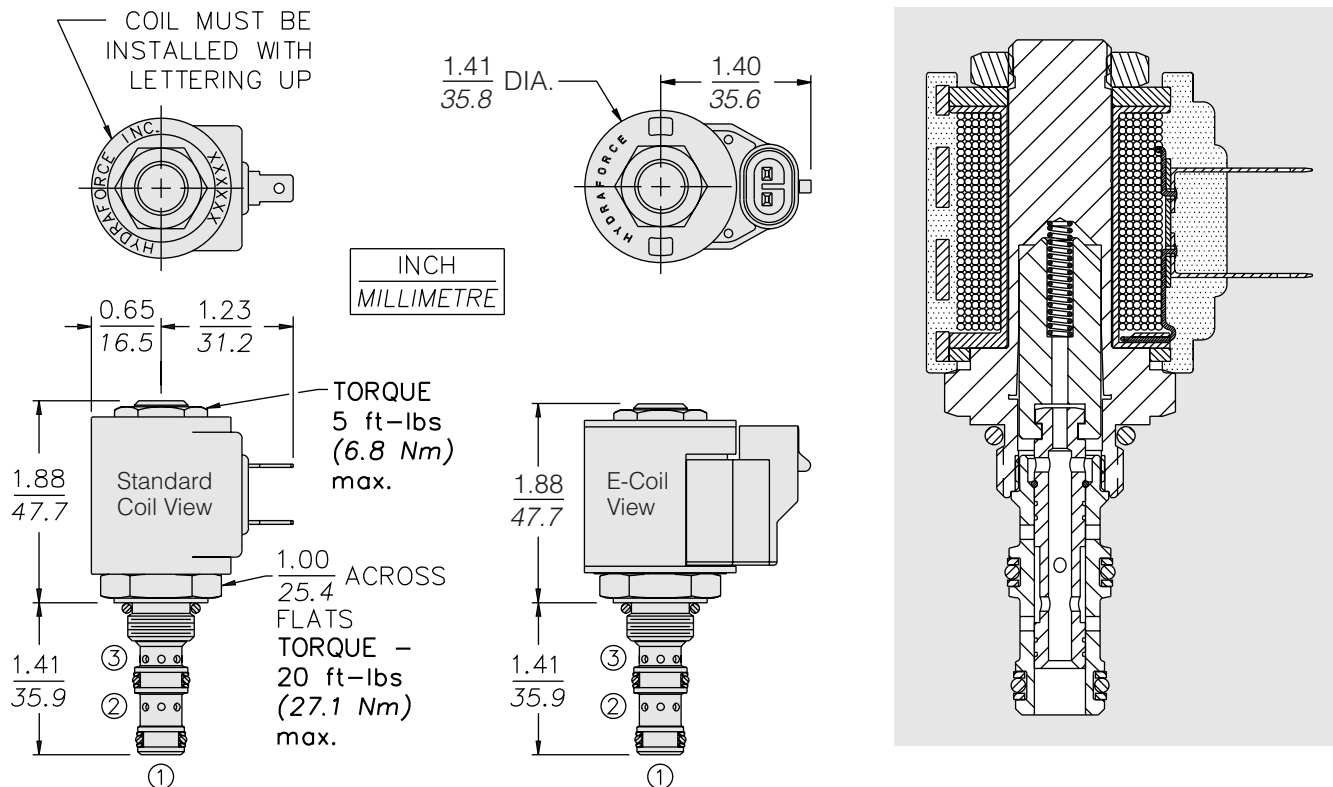

**MATERIALS**

**Cartridge:** Weight: 0.09 kg. (0.20 lbs.); Steel with hardened work surfaces. Zinc-plated exposed surfaces; Buna N O-rings and back-ups standard.

**Standard Coil:** Weight: 0.11 kg. (0.25 lbs.); Unitized thermoplastic encapsulated, Class H high temperature magnetwire; See page 3.200.1.

**E-Coil:** Weight: 0.14 kg. (0.3 lbs.); Fully encapsulated with rugged external metal shell; Rated up to IP69K with integral connectors; **Note: See page 3.400.1 for all E-Coil retrofit applications.**

**TO ORDER**

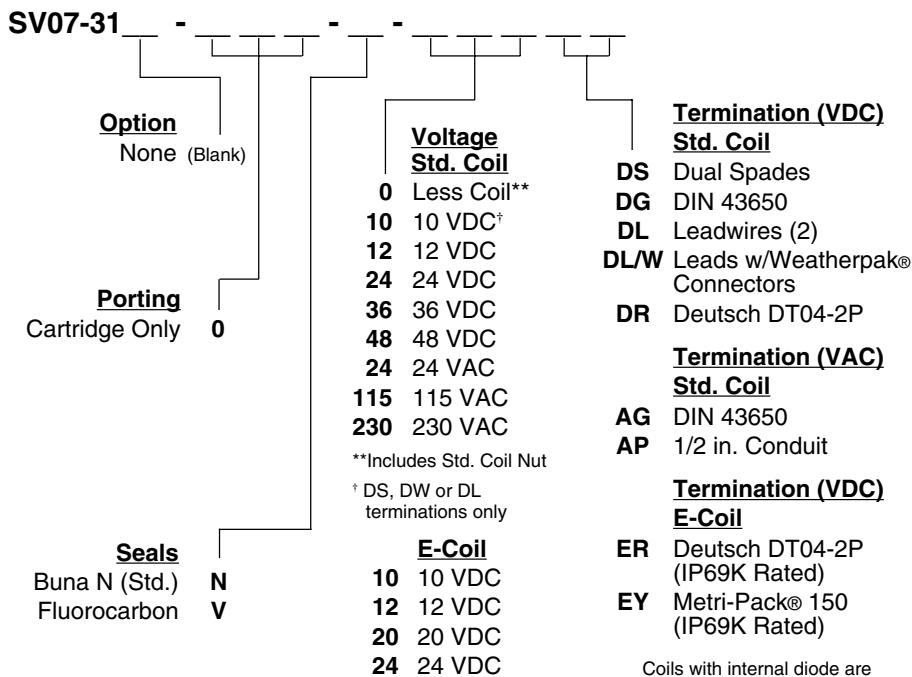

Coils with internal diode are available. Consult factory.