

SOLENOID VALVES

SV12-24 Spool, 2-Way, Normally Closed

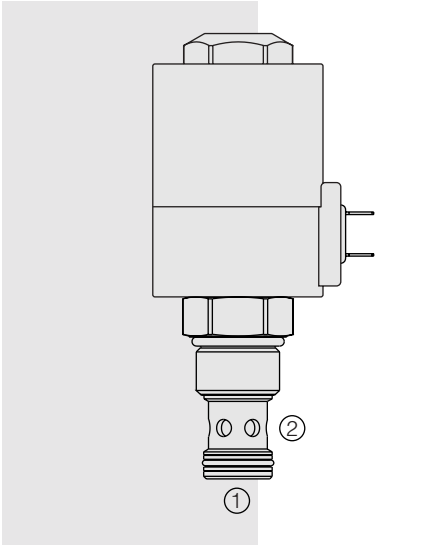

DESCRIPTION

A solenoid-operated, 2-way, normally closed, direct-acting spool-type, screw-in hydraulic cartridge valve, designed to function as a bidirectional blocking valve.

OPERATION

When de-energized, the **SV12-24** blocks flow in both directions. When energized, the valve's spool shifts to allow flow in both directions.

FEATURES

- Continuous-duty rated solenoid.
- Hardened spool and cage for long life.
- Optional coil voltages and terminations.
- All ports may be fully pressurized.
- Heavy-duty water resistant E-Coils rated up to IP69K.

RATINGS

Operating Pressure: 240 bar (3500 psi) max.

Flow: See Performance Chart

Leakage: 410 cc/minute (25 cu. in./minute) at 240 bar (3500 psi)

Temperature: -40 to 120°C with Buna N seals

Coil Duty Rating: See Chart

Response Time: Pull-In: 100 msec; Drop-Out: 100 msec

Initial Coil Current Draw at 20°C: 2.8 amps at 12 VDC

Filtration: See page 9.010.1

Fluids: Mineral-based or synthetics with lubricating properties at viscosities of 7.4 to 420 cSt (50 to 2000 ssu)

Installation: No restrictions; See page 9.020.1

Cavity: VC12-2; See page 9.112.1

Cavity Tool: CT12-2XX; See page 8.600.1

Seal Kit: SK12-2X-M; See page 8.650.1

E-Coil Nut: Part No. 7085180

SYMBOLS

USAS/ISO:

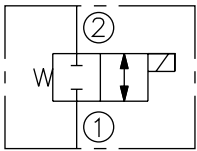

PERFORMANCE (Cartridge Only)

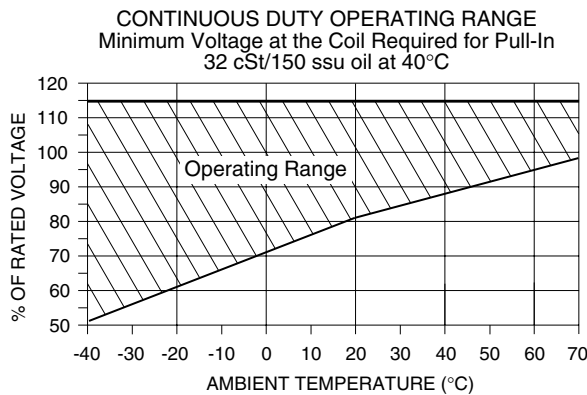
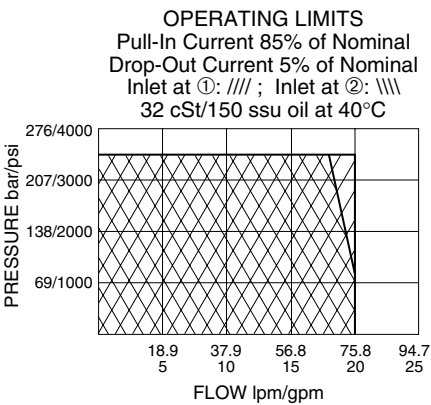
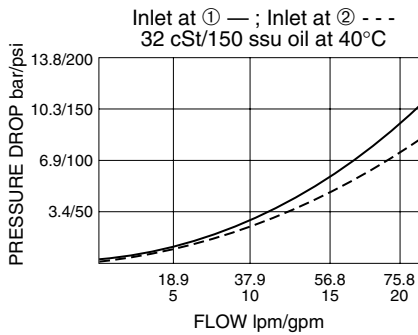

DIMENSIONS

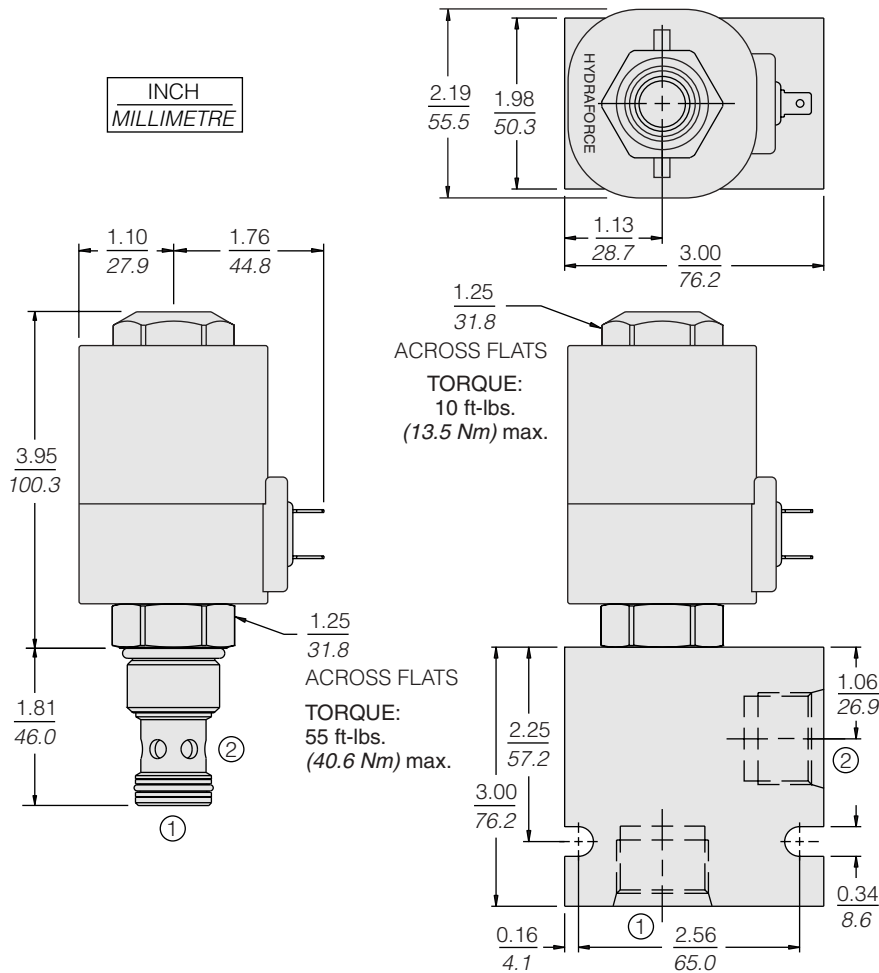

MATERIALS

Cartridge: Weight: 0.25 kg. (0.55 lbs.); Steel with hardened work surfaces. Zinc-plated exposed surfaces; Buna N O-rings and TFE back-ups standard.

Standard Ported Body: Weight: 0.57 kg. (1.25 lbs.); Anodized high-strength 6061 T6 aluminum alloy, rated to 240 bar (3500 psi); See page 8.012.1. Ductile iron and steel bodies available; dimensions may differ; consult factory.

E-Coil: Weight: 1.36 kg. (3.0 lbs.); Fully encapsulated with rugged external metal shell; Rated up to IP69K with integral connectors; See page 3.400.1.

TO ORDER

SV12-24		Terminations (VDC)	
Porting		EL	Leadwires (2), IP65 Rated
Cartridge Only	0	ES	Dual Spades, IP65 Rated
SAE 10	10T	EG	DIN 43650, IP65 Rated
SAE 12	12T	EW	Leads w/Weather-Pack® Connector, IP65 Rated
SAE 16	16T	EY	Metri-Pack® 150 Connector, IP69K Rated
1/2 in. BSP*	4B		
3/4 in. BSP*	6B		
*BSP Body; U.K. Mfrs. Only		Voltage	
		0	Less Coil
		12	12 VDC
		24	24 VDC
		36	36 VDC
		48	48 VDC
Seals			Coils with internal diode are available. Consult factory.
Buna N (Std.)	N		
Fluorocarbon	V		
			Other coil voltages may be available for OEM applications. Consult factory.