

# SOLENOID VALVES

## SV12-22 Poppet, 2-Way, Normally Closed

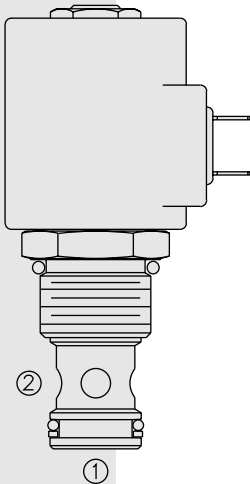

### DESCRIPTION

A solenoid-operated, 2-way, normally closed, poppet-type, screw-in hydraulic cartridge valve, designed to function as a load holding or blocking valve in applications requiring low internal leakage.

### OPERATION

When de-energized, the SV12-22 acts as a check valve, allowing flow to pass from ① to ②, while blocking flow in the reverse direction.

When energized, the poppet lifts to open the ② to ① flow path. In this mode, flow is also allowed from ① to ②.

**Operation of Manual Override Option:** To override, push button in, twist counter-clockwise 180° and release. In this position, the valve will remain open.

To return to normal operation, push button in, twist clockwise 180° and release. Override will be detented in this position.

### FEATURES

- Continuous-duty rated solenoid.
- Hardened seat for long life and low leakage.
- Optional coil voltages and terminations.
- Efficient wet-armature construction.
- Cartridges are voltage interchangeable.
- Unitized, molded coil design.
- Manual override option.
- Optional waterproof E-Coils rated up to IP69K.
- Cost effective cavity.

### RATINGS

**Operating Pressure:** 240 bar (3500 psi)

**Proof Pressure:** 390 bar (5700 psi)

**Flow:** See Performance Chart

**Internal Leakage:** 0.15 cc/minute (3 drops/minute) max. at 240 bar (3500 psi)

**Temperature:** -40 to 120°C with standard Buna seals

**Coil Duty Rating:** Continuous from 85% to 115% of nominal voltage

**Response Time:** First indication of change of state with 100% voltage supplied at 80% of nominal flow rating: Energized: 40 msec.; De-energized: 80 msec.

**Initial Coil Current Draw at 20°C:** Standard Coil: 1.67 amps at 12 VDC; 0.18 amps at 115 VAC (full wave rectified). E-Coil: 2.0 amps at 12 VDC; 1.0 amps at 24 VDC

**Minimum Pull-in Voltage:** 85% of nominal at 207 bar (3000 psi)

**Filtration:** See page 9.010.1

**Fluids:** Mineral-based or synthetics with lubricating properties at viscosities of 7.4 to 420 cSt (50 to 2000 ssu)

**Installation:** No restrictions; See page 9.020.1

**Cavity:** VC12-2; See page 9.112.1

**Cavity Tool:** CT12-2XX; See page 8.600.1

**Seal Kit:** SK12-2X-T; See page 8.650.1

**Coil Nut:** Part No. 7004400;

For E-coils manufactured prior to 1-1-04, see page 3.400.1 for coil nut info.

### SYMBOLS

#### USASI:

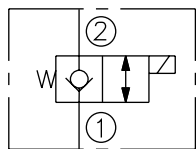

#### ISO:

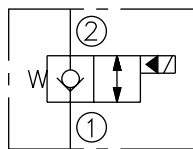

### PERFORMANCE (Cartridge Only)

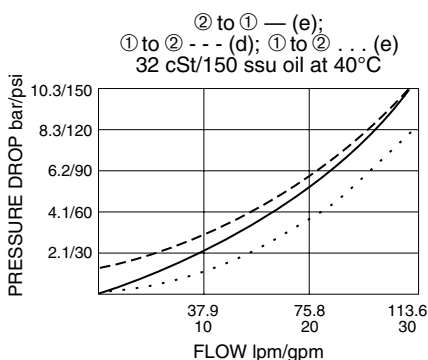

**DIMENSIONS**

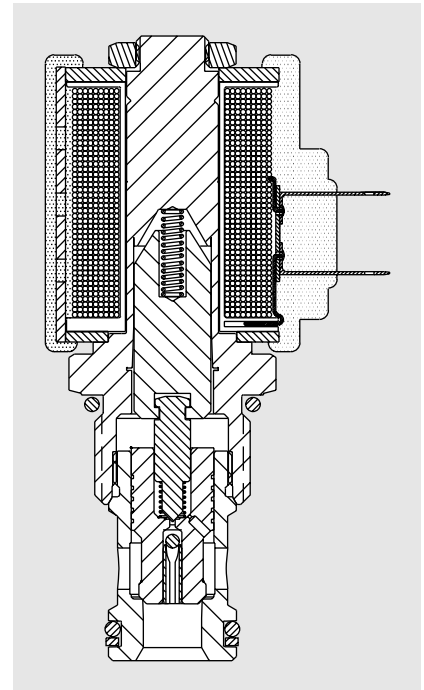
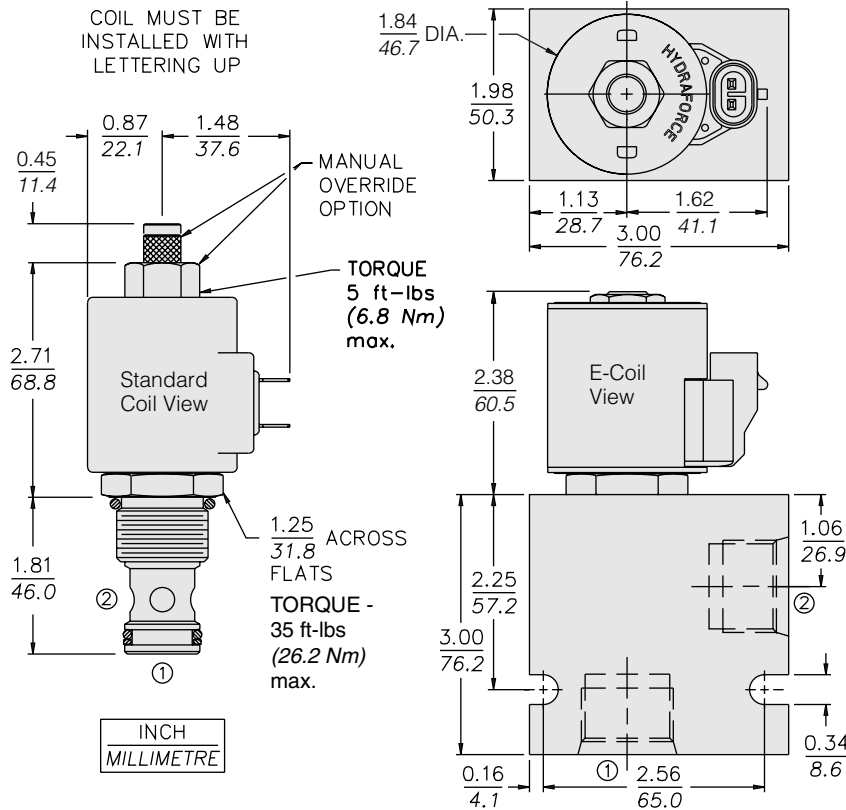

**MATERIALS**

**Cartridge:** Weight: 0.25 kg. (0.55 lbs.); Steel with hardened work surfaces. Zinc-plated exposed surfaces. Buna N O-rings and polyester elastomer back-up standard.

**Standard Ported Body:** Weight: 0.57 kg. (1.25 lbs.); Anodized high-strength 6061 T6 aluminum alloy, rated to 240 bar (3500 psi); See page 8.012.1. Ductile iron and steel bodies available; dimensions may differ; consult factory.

**Standard Coil:** Weight: 0.27 kg. (0.60 lbs.); Unitized thermoplastic encapsulated, Class H high temperature magnetwire; See page 3.200.1.

**E-Coil:** Weight: 0.41 kg. (0.9 lbs.); Fully encapsulated with rugged external metal shell; Rated up to IP69K with integral connectors; **Note: See page 3.400.1 for all E-Coil retrofit applications.**

**TO ORDER**

**SV12-22**

<b>Options</b>		<b>Voltage</b>		<b>Termination (VDC)</b>	
None (Blank)		<b>Std. Coil</b>		<b>Std. Coil</b>	
Manual Override <b>M</b>		<b>0</b> Less Coil**		<b>DS</b> Dual Spades	
Manual Override <b>Y</b>		<b>10</b> 10 VDC†		<b>DG</b> DIN 43650	
Manual Override <b>J</b>		<b>12</b> 12 VDC		<b>DL</b> Leadwires (2)	
For Manual Override options see page 1.001.1		<b>24</b> 24 VDC		<b>DL/W</b> Leads w/Weatherpak® Connectors	
		<b>36</b> 36 VDC		<b>DR</b> Deutsch DT04-2P	
		<b>48</b> 48 VDC			
<b>Porting</b>		<b>24</b> 24 VAC		<b>Termination (VAC)</b>	
Cartridge Only <b>0</b>		<b>115</b> 115 VAC		<b>Std. Coil</b>	
SAE 10 <b>10T</b>		<b>230</b> 230 VAC		<b>AG</b> DIN 43650	
SAE 12 <b>12T</b>		**Includes Std. Coil Nut		<b>AP</b> 1/2 in. Conduit	
SAE 16 <b>16T</b>		† DS, DW or DL terminations only			
3/4 in. BSP* <b>6B</b>				<b>Termination (VDC)</b>	
1 in. BSP* <b>8B</b>				<b>E-Coil</b>	
*BSP Body; U.K. Mfrs. Only		<b>E-Coil</b>		<b>ER</b> Deutsch DT04-2P (IP69K Rated)	
		<b>10</b> 10 VDC		<b>EY</b> Metri-Pack® 150 (IP69K Rated)	
<b>Seals</b>		<b>12</b> 12 VDC			
Buna N (Std.) <b>N</b>		<b>20</b> 20 VDC			
Fluorocarbon <b>V</b>		<b>24</b> 24 VDC			

Coils with internal diode are available. Consult factory.