

# SOLENOID VALVES

## SV10-22 Poppet, 2-Way, Normally Closed

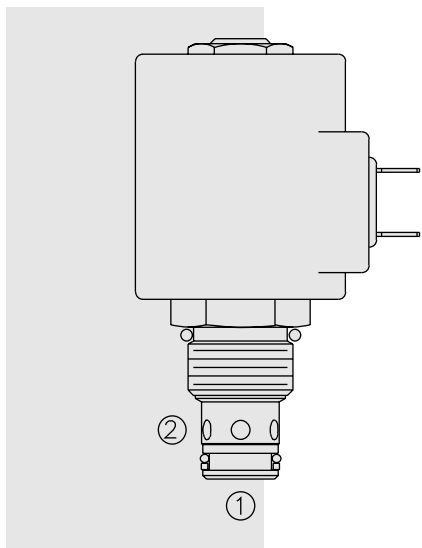

### DESCRIPTION

A solenoid-operated, 2-way, normally closed, poppet-type, screw-in hydraulic cartridge valve, designed for low leakage blocking and load holding applications.

### OPERATION

When de-energized, the **SV10-22** acts as a check valve, allowing flow to pass from ① to ②, while blocking flow from ② to ①.

When energized, the poppet lifts to open the ② to ① flow path. In this mode, flow is also allowed from ① to ②.

**Operation of Manual Override Option:** To override, push button in, twist counter-clockwise 180° and release. In this position, the valve will remain open.

To return to normal operation, push button in, twist clockwise 180° and release. Override will be detented in this position.

### FEATURES

- Continuous-duty rated solenoid.
- Hardened seat for long life and low leakage.
- Optional coil voltages and terminations.
- Efficient wet-armature construction.
- Cartridges are voltage interchangeable.
- Manual override option.
- Optional waterproof E-Coils rated up to IP69K.
- Unitized, molded coil design.
- Industry common cavity.

### SYMBOLS

#### USASI:

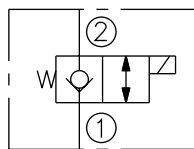

#### ISO:

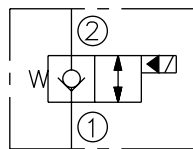

### PERFORMANCE (Cartridge Only)

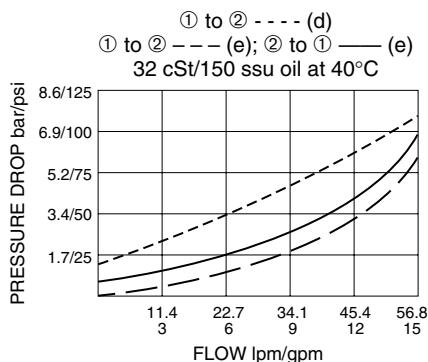

### RATINGS

**Operating Pressure:** 207 bar (3000 psi)

**Proof Pressure:** 350 bar (5075 psi)

**Flow:** See Performance Chart

**Internal Leakage:** 0.15 cc/minute (3 drops/minute) max. at 207 bar (3000 psi)

**Temperature:** -40 to 120°C with standard Buna seals

**Coil Duty Rating:** Continuous from 85% to 115% of nominal voltage

**Response Time:** First indication of change of state with 100% voltage supplied at 80% of nominal flow rating: Energized: 40 msec.; De-energized: 32 msec.

**Initial Coil Current Draw at 20°C:** Standard Coil: 1.67 amps at 12 VDC; 0.18 amps at 115 VAC (full wave rectified). E-Coil: 2.0 amps at 12 VDC; 1.0 amps at 24 VDC

**Minimum Pull-in Voltage:** 85% of nominal at 207 bar (3000 psi)

**Filtration:** See page 9.010.1

**Fluids:** Mineral-based or synthetics with lubricating properties at viscosities of 7.4 to 420 cSt (50 to 2000 ssu)

**Installation:** No restrictions; See page 9.020.1

**Cavity:** VC10-2; See page 9.110.1

**Cavity Tool:** CT10-2XX; See page 8.600.1

**Seal Kit:** SK10-2X-T; See page 8.650.1

**Coil Nut:** Part No. 7004400;

For E-coils manufactured prior to 1-1-04, see page 3.400.1 for coil nut info.

## DIMENSIONS

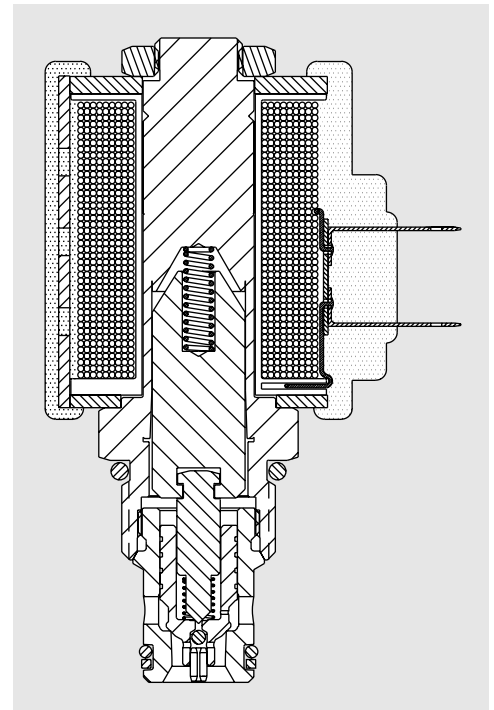
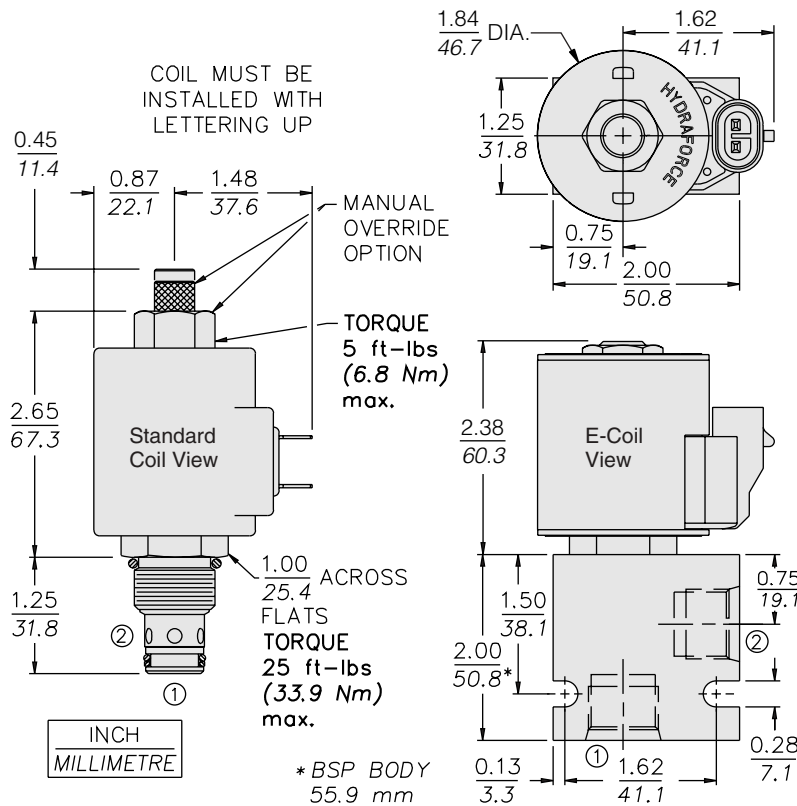

## MATERIALS

**Cartridge:** Weight: 0.16 kg. (0.35 lbs.); Steel with hardened work surfaces. Zinc-plated exposed surfaces. Buna N O-rings and polyester elastomer back-up standard.

**Standard Ported Body:** Weight: 0.16 kg. (0.35 lbs.); Anodized high-strength 6061 T6 aluminum alloy, rated to 240 bar (3500 psi); See page 8.010.1. Ductile iron and steel bodies available; dimensions may differ; consult factory.

**Standard Coil:** Weight: 0.27 kg. (0.60 lbs.); Unitized thermoplastic encapsulated, Class H high temperature magnetwire; See page 3.200.1.

**E-Coil:** Weight: 0.41 kg. (0.9 lbs.); Fully encapsulated with rugged external metal shell; Rated up to IP69K with integral connectors; **Note: See page 3.400.1 for all E-Coil retrofit applications.**

## TO ORDER

### SV10-22

<b>Option</b>	None (Blank)
Manual Override	<b>M</b>
Manual Override	<b>Y</b>
Manual Override	<b>J</b>
For Manual Override options see page 1.001.1	
<b>Porting</b>	
Cartridge Only	<b>0</b>
SAE 6	<b>6T</b>
SAE 8	<b>8T</b>
1/4 in. BSP*	<b>2B</b>
3/8 in. BSP*	<b>3B</b>
1/2 in. BSP*	<b>4B</b>
*BSP Body; U.K. Mfr. Only	

<b>Seals</b>	
Buna N (Std.)	<b>N</b>
Fluorocarbon	<b>V</b>

<b>Voltage Std. Coil</b>	
<b>0</b>	Less Coil**
<b>10</b>	10 VDC†
<b>12</b>	12 VDC
<b>24</b>	24 VDC
<b>36</b>	36 VDC
<b>48</b>	48 VDC
<b>24</b>	24 VAC
<b>115</b>	115 VAC
<b>230</b>	230 VAC

\*\*Includes Std. Coil Nut

† DS, DW or DL terminations only

<b>E-Coil</b>	
<b>10</b>	10 VDC
<b>12</b>	12 VDC
<b>20</b>	20 VDC
<b>24</b>	24 VDC

<b>Termination (VDC) Std. Coil</b>	
<b>DS</b>	Dual Spades
<b>DG</b>	DIN 43650
<b>DL</b>	Leadwires (2)
<b>DL/W</b>	Leads w/Weatherpak® Connectors
<b>DR</b>	Deutsch DT04-2P
<b>Termination (VAC) Std. Coil</b>	
<b>AG</b>	DIN 43650
<b>AP</b>	1/2 in. Conduit
<b>Termination (VDC) E-Coil</b>	
<b>ER</b>	Deutsch DT04-2P (IP69K Rated)
<b>EY</b>	Metri-Pack® 150 (IP69K Rated)

Coils with internal diode are available. Consult factory.