

SOLENOID VALVES

SV12-20 Poppet, 2-Way, Normally Closed

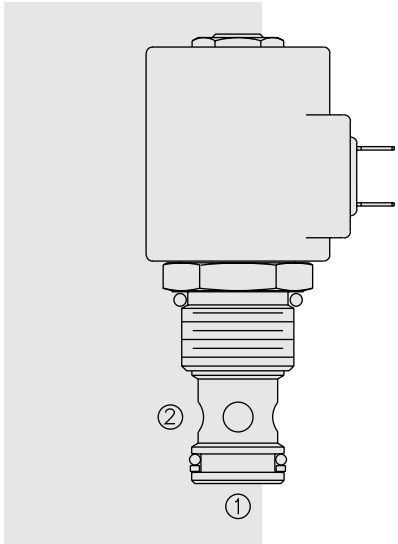

DESCRIPTION

A solenoid-operated, 2-way, normally closed, poppet-type, screw-in hydraulic cartridge valve, designed to function as a load holding or blocking valve in applications requiring low internal leakage.

OPERATION

When de-energized, the **SV12-20** acts as a check valve, allowing flow to pass from ① to ②, while blocking flow in the reverse direction.

When energized, the poppet lifts to open the ② to ① flow path. In this mode, flow from ① to ② is severely restricted. If this path is required, see model SV12-22, page 1.045.1.

Operation of Manual Override Option: To override, push button in, twist counter-clockwise 180° and release. In this position, the valve will remain open.

To return to normal operation, push button in, twist clockwise 180° and release. Override will be detented in this position.

FEATURES

- Continuous-duty rated solenoid.
- Hardened seat for long life and low leakage.
- Optional coil voltages and terminations.
- Efficient wet-armature construction.
- Cartridges are voltage interchangeable.
- Manual override option.
- Optional waterproof E-Coils rated up to IP69K.
- Unitized, molded coil design.
- Cost effective cavity.

SYMBOLS

USASI:

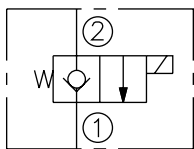

ISO:

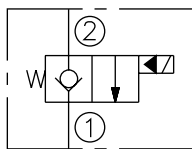

PERFORMANCE (Cartridge Only)

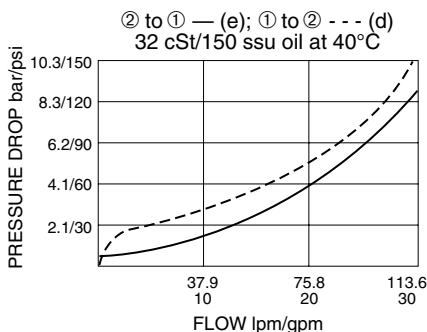

RATINGS

Operating Pressure: 240 bar (3500 psi)

Proof Pressure: 390 bar (5700 psi)

Flow: See Performance Chart

Internal Leakage: 0.15 cc/minute (3 drops/minute) max. at 240 bar (3500 psi)

Temperature: -40 to 120°C with standard Buna seals

Coil Duty Rating: Continuous from 85% to 115% of nominal voltage

Response Time: First indication of change of state with 100% voltage supplied at 80% of nominal flow rating: Energized: 40 msec.; De-energized: 80 msec.

Initial Coil Current Draw at 20°C: Standard Coil: 1.67 amps at 12 VDC; 0.18 amps at 115 VAC (full wave rectified); E-Coil: 2.0 amps at 12 VDC; 1.0 amps at 24 VDC

Minimum Pull-in Voltage: 85% of nominal at 207 bar (3000 psi)

Filtration: See page 9.010.1

Fluids: Mineral-based or synthetics with lubricating properties at viscosities of 7.4 to 420 cSt (50 to 2000 ssu)

Installation: No restrictions; See page 9.020.1

Cavity: VC12-2; See page 9.112.1

Cavity Tool: CT12-2XX; See page 8.600.1

Seal Kit: SK12-2X-T; See page 8.650.1

Coil Nut: Part No: 7004400;

For E-coils manufactured prior to 1-1-04, see page 3.400.1 for coil nut info.

SV12-20

DIMENSIONS

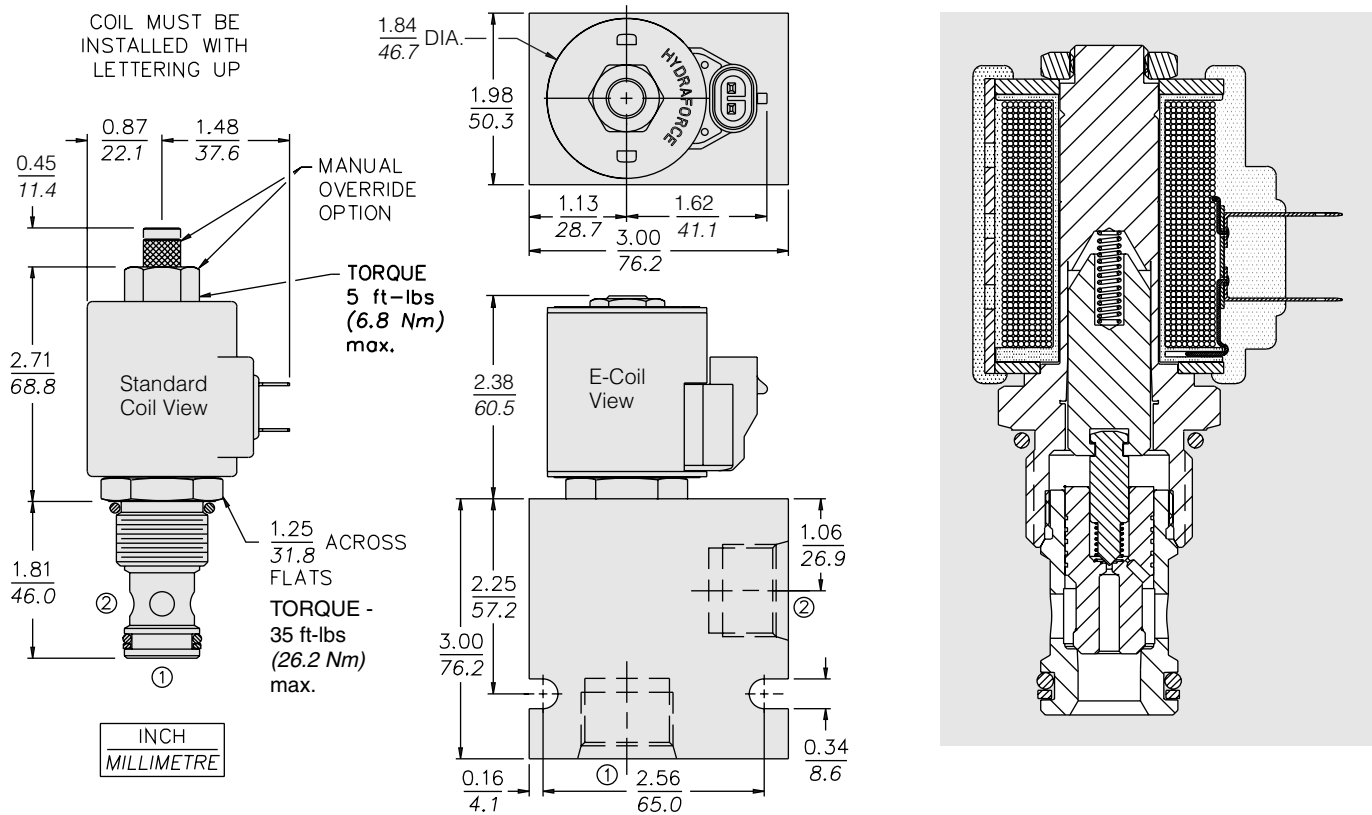

MATERIALS

Cartridge: Weight: 0.25 kg. (0.55 lbs.); Steel with hardened work surfaces. Zinc-plated exposed surfaces. Buna N O-rings and polyester elastomer back-up standard.

Standard Ported Body: Weight: 0.57 kg. (1.25 lbs.); Anodized high-strength 6061 T6 aluminum alloy, rated to 240 bar (3500 psi); See page 8.012.1. Ductile iron and steel bodies available; dimensions may differ; consult factory.

Standard Coil: Weight: 0.27 kg. (0.60 lbs.); Unitized thermoplastic encapsulated, Class H high temperature magnetwire; See page 3.200.1.

E-Coil: Weight: 0.41 kg. (0.9 lbs.); Fully encapsulated with rugged external metal shell; Rated up to IP69K with integral connectors; **Note: See page 3.400.1 for all E-Coil retrofit applications.**

TO ORDER

SV12-20

Options		Voltage Std. Coil		Termination (VDC) Std. Coil	
None (Blank)		0	Less Coil**	DS	Dual Spades
Manual Override	M	10	10 VDC†	DG	DIN 43650
Manual Override	Y	12	12 VDC	DL	Leadwires (2)
Manual Override	J	24	24 VDC	DL/W	Leads w/Weatherpak® Connectors
For Manual Override options see page 1.001.1		36	36 VDC	DR	Deutsch DT04-2P
		48	48 VDC	Termination (VAC) Std. Coil	
		24	24 VAC	AG	DIN 43650
		115	115 VAC	AP	1/2 in. Conduit
		230	230 VAC	Termination (VDC) E-Coil	
		**Includes Std. Coil Nut		ER	Deutsch DT04-2P (IP69K Rated)
		† DS, DW or DL terminations only		EY	Metri-Pack® 150 (IP69K Rated)
				Termination (VDC) E-Coil	
				ER	Deutsch DT04-2P (IP69K Rated)
				EY	Metri-Pack® 150 (IP69K Rated)
				Termination (VDC) E-Coil	
				ER	Deutsch DT04-2P (IP69K Rated)
				EY	Metri-Pack® 150 (IP69K Rated)
				Termination (VDC) E-Coil	
				ER	Deutsch DT04-2P (IP69K Rated)
				EY	Metri-Pack® 150 (IP69K Rated)
				Termination (VDC) E-Coil	
				ER	Deutsch DT04-2P (IP69K Rated)
				EY	Metri-Pack® 150 (IP69K Rated)
				Termination (VDC) E-Coil	
				ER	Deutsch DT04-2P (IP69K Rated)
				EY	Metri-Pack® 150 (IP69K Rated)
				Termination (VDC) E-Coil	
				ER	Deutsch DT04-2P (IP69K Rated)
				EY	Metri-Pack® 150 (IP69K Rated)
				Termination (VDC) E-Coil	
				ER	Deutsch DT04-2P (IP69K Rated)
				EY	Metri-Pack® 150 (IP69K Rated)
				Termination (VDC) E-Coil	
				ER	Deutsch DT04-2P (IP69K Rated)
				EY	Metri-Pack® 150 (IP69K Rated)
				Termination (VDC) E-Coil	
				ER	Deutsch DT04-2P (IP69K Rated)
				EY	Metri-Pack® 150 (IP69K Rated)
				Termination (VDC) E-Coil	
				ER	Deutsch DT04-2P (IP69K Rated)
				EY	Metri-Pack® 150 (IP69K Rated)
				Termination (VDC) E-Coil	
				ER	Deutsch DT04-2P (IP69K Rated)
				EY	Metri-Pack® 150 (IP69K Rated)
				Termination (VDC) E-Coil	
				ER	Deutsch DT04-2P (IP69K Rated)
				EY	Metri-Pack® 150 (IP69K Rated)
				Termination (VDC) E-Coil	
				ER	Deutsch DT04-2P (IP69K Rated)
				EY	Metri-Pack® 150 (IP69K Rated)
				Termination (VDC) E-Coil	
				ER	Deutsch DT04-2P (IP69K Rated)
				EY	Metri-Pack® 150 (IP69K Rated)
				Termination (VDC) E-Coil	
				ER	Deutsch DT04-2P (IP69K Rated)
				EY	Metri-Pack® 150 (IP69K Rated)
				Termination (VDC) E-Coil	
				ER	Deutsch DT04-2P (IP69K Rated)
				EY	Metri-Pack® 150 (IP69K Rated)
				Termination (VDC) E-Coil	
				ER	Deutsch DT04-2P (IP69K Rated)
				EY	Metri-Pack® 150 (IP69K Rated)
				Termination (VDC) E-Coil	
				ER	Deutsch DT04-2P (IP69K Rated)
				EY	Metri-Pack® 150 (IP69K Rated)
				Termination (VDC) E-Coil	
				ER	Deutsch DT04-2P (IP69K Rated)
				EY	Metri-Pack® 150 (IP69K Rated)
				Termination (VDC) E-Coil	
				ER	Deutsch DT04-2P (IP69K Rated)
				EY	Metri-Pack® 150 (IP69K Rated)
				Termination (VDC) E-Coil	
				ER	Deutsch DT04-2P (IP69K Rated)
				EY	Metri-Pack® 150 (IP69K Rated)
				Termination (VDC) E-Coil	
				ER	Deutsch DT04-2P (IP69K Rated)
				EY	Metri-Pack® 150 (IP69K Rated)
				Termination (VDC) E-Coil	
				ER	Deutsch DT04-2P (IP69K Rated)
				EY	Metri-Pack® 150 (IP69K Rated)
				Termination (VDC) E-Coil	
				ER	Deutsch DT04-2P (IP69K Rated)
				EY	Metri-Pack® 150 (IP69K Rated)
				Termination (VDC) E-Coil	
				ER	Deutsch DT04-2P (IP69K Rated)
				EY	Metri-Pack® 150 (IP69K Rated)
				Termination (VDC) E-Coil	
				ER	Deutsch DT04-2P (IP69K Rated)
				EY	Metri-Pack® 150 (IP69K Rated)
				Termination (VDC) E-Coil	
				ER	Deutsch DT04-2P (IP69K Rated)
				EY	Metri-Pack® 150 (IP69K Rated)
				Termination (VDC) E-Coil	
				ER	Deutsch DT04-2P (IP69K Rated)
				EY	Metri-Pack® 150 (IP69K Rated)
				Termination (VDC) E-Coil	
				ER	Deutsch DT04-2P (IP69K Rated)
				EY	Metri-Pack® 150 (IP69K Rated)
				Termination (VDC) E-Coil	
				ER	Deutsch DT04-2P (IP69K Rated)
				EY	Metri-Pack® 150 (IP69K Rated)
				Termination (VDC) E-Coil	
				ER	Deutsch DT04-2P (IP69K Rated)
				EY	Metri-Pack® 150 (IP69K Rated)
				Termination (VDC) E-Coil	
				ER	Deutsch DT04-2P (IP69K Rated)
				EY	Metri-Pack® 150 (IP69K Rated)
				Termination (VDC) E-Coil	
				ER	Deutsch DT04-2P (IP69K Rated)
				EY	Metri-Pack® 150 (IP69K Rated)
				Termination (VDC) E-Coil	
				ER	Deutsch DT04-2P (IP69K Rated)
				EY	Metri-Pack® 150 (IP69K Rated)
				Termination (VDC) E-Coil	
				ER	Deutsch DT04-2P (IP69K Rated)
				EY	Metri-Pack® 150 (IP69K Rated)
				Termination (VDC) E-Coil	
				ER	Deutsch DT04-2P (IP69K Rated)
				EY	Metri-Pack® 150 (IP69K Rated)
				Termination (VDC) E-Coil	
				ER	Deutsch DT04-2P (IP69K Rated)
				EY	Metri-Pack® 150 (IP69K Rated)
				Termination (VDC) E-Coil	
				ER	Deutsch DT04-2P (IP69K Rated)
				EY	Metri-Pack® 150 (IP69K Rated)
				Termination (VDC) E-Coil	
				ER	Deutsch DT04-2P (IP69K Rated)
				EY	Metri-Pack® 150 (IP69K Rated)
				Termination (VDC) E-Coil	
				ER	Deutsch DT04-2P (IP69K Rated)
				EY	Metri-Pack® 150 (IP69K Rated)
				Termination (VDC) E-Coil	
				ER	Deutsch DT04-2P (IP69K Rated)
				EY	Metri-Pack® 150 (IP69K Rated)
				Termination (VDC) E-Coil	
				ER	Deutsch DT04-2P (IP69K Rated)
				EY	Metri-Pack® 150 (IP69K Rated)
				Termination (VDC) E-Coil	
				ER	Deutsch DT04-2P (IP69K Rated)
				EY	Metri-Pack® 150 (IP69K Rated)
				Termination (VDC) E-Coil	
				ER	Deutsch DT04-2P (IP69K Rated)
				EY	Metri-Pack® 150 (IP69K Rated)
				Termination (VDC) E-Coil	
				ER	Deutsch DT04-2P (IP69K Rated)
				EY	Metri-Pack® 150 (IP69K Rated)
				Termination (VDC) E-Coil	
				ER	Deutsch DT04-2P (IP69K Rated)
				EY	Metri-Pack® 150 (IP69K Rated)
				Termination (VDC) E-Coil	
				ER	Deutsch DT04-2P (IP69K Rated)
				EY	Metri-Pack® 150 (IP69K Rated)
				Termination (VDC) E-Coil	
				ER	Deutsch DT04-2P (IP69K Rated)
				EY	Metri-Pack® 150 (IP69K Rated)
				Termination (VDC) E-Coil	
				ER	Deutsch DT04-2P (IP69K Rated)
				EY	Metri-Pack® 150 (IP69K Rated)
				Termination (VDC) E-Coil	
				ER	Deutsch DT04-2P (IP69K Rated)
				EY	Metri-Pack® 150 (IP69K Rated)
				Termination (VDC) E-Coil	
				ER	Deutsch DT04-2P (IP69K Rated)
				EY	Metri-Pack® 150 (IP69K Rated)
				Termination (VDC) E-Coil	
				ER	Deutsch DT04-2P (IP69K Rated)
				EY	Metri-Pack® 150 (IP69K Rated)
				Termination (VDC) E-Coil	
				ER	Deutsch DT04-2P (IP69K Rated)
				EY	Metri-Pack® 150 (IP69K Rated)
				Termination (VDC) E-Coil	
				ER	Deutsch DT04-2P (IP69K Rated)
				EY	Metri-Pack® 150 (IP69K Rated)
				Termination (VDC) E-Coil	
				ER	Deutsch DT04-2P (IP69K Rated)
				EY	Metri-Pack® 150 (IP69K Rated)
				Termination (VDC) E-Coil	
				ER	Deutsch DT04-2P (IP69K Rated)
				EY	Metri-Pack® 150 (IP69K Rated)
				Termination (VDC) E-Coil	
				ER	Deutsch DT04-2P (IP69K Rated)
				EY	Metri-Pack® 150 (IP69K Rated)
				Termination (VDC) E-Coil	
				ER	Deutsch DT04-2P (IP69K Rated)
				EY	Metri-Pack® 150 (IP69K Rated)
				Termination (VDC) E-Coil	
				ER	Deutsch DT04-2P (IP69K Rated)
				EY	Metri-Pack® 150 (IP69K Rated)
				Termination (VDC) E-Coil	
				ER	Deutsch DT04-2P (IP69K Rated)
				EY	Metri-Pack® 150 (IP69K Rated)
				Termination (VDC) E-Coil	
				ER	Deutsch DT04-2P (IP69K Rated)
				EY	Metri-Pack® 150 (IP69K Rated)
				Termination (VDC) E-Coil	
				ER	Deutsch DT04-2P (IP69K Rated)
				EY	Metri-Pack® 150 (IP69K Rated)
				Termination (VDC) E-Coil	
				ER	Deutsch DT04-2P (IP69K Rated)
				EY	Metri-Pack® 150 (IP69K Rated)
				Termination (VDC) E-Coil	
				ER	Deutsch DT04-2P (IP69K Rated)
				EY	Metri-Pack® 150 (IP69K Rated)
				Termination (VDC) E-Coil	
				ER	Deutsch DT04-2P (IP69K Rated)
				EY	Metri-Pack® 150 (IP69K Rated)
				Termination (VDC) E-Coil	
				ER	Deutsch DT04-2P (IP69K Rated)
				EY	Metri-Pack® 150 (IP69K Rated)
				Termination (VDC) E-Coil	
				ER	Deutsch DT04-2P (IP69K Rated)
				EY	Metri-Pack® 150 (IP69K Rated)
				Termination (VDC) E-Coil	
				ER	Deutsch DT04-2P (IP69K Rated)
				EY	Metri-Pack® 150 (IP69K Rated)
				Termination (VDC) E-Coil	
				ER	Deutsch DT04-2P (IP69K Rated)
				EY	Metri-Pack® 150 (IP69K Rated)
				Termination (VDC) E-Coil	
				ER	Deutsch DT04-2P (IP69K Rated)
				EY	Metri-Pack® 150 (IP69K Rated)
				Termination (VDC) E-Coil	
				ER	Deutsch DT04-2P (IP69K Rated)
				EY	Metri-Pack® 150 (IP69K Rated)
				Termination (VDC) E-Coil	
				ER	Deutsch DT04-2P (IP69K Rated)
				EY	Metri-Pack® 150 (IP69K Rated)
				Termination (VDC) E-Coil	
				ER	Deutsch DT04-2P (IP69K Rated)
				EY	Metri-Pack® 150 (IP69K Rated)
				Termination (VDC) E-Coil	
				ER	Deutsch DT04-2P (IP69K Rated)
				EY	Metri-Pack® 150 (IP69K Rated)
				Termination (VDC) E-Coil	
				ER	Deutsch DT04-2P (IP69K Rated)
				EY	Metri-Pack® 150 (IP69K Rated)