

SOLENOID VALVES

SF08-20 Poppet, 2-Way, N.C., High Pressure

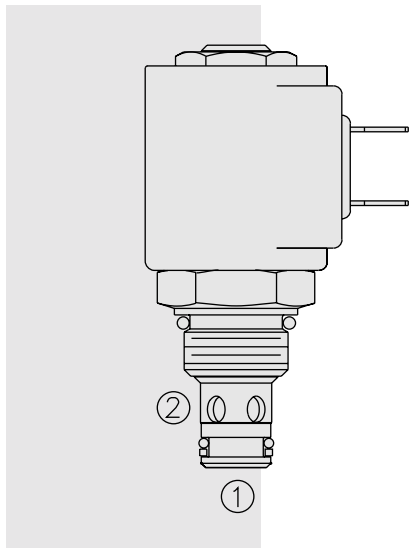

DESCRIPTION

A solenoid-operated, 2-way, normally closed, piloted poppet-type, screw-in hydraulic cartridge valve, intended to act as a blocking or load-holding device for low flow circuits.

OPERATION

When de-energized, the SF08-20 acts as a check valve, allowing flow from ① to ②, while blocking flow from ② to ①.

When energized, the cartridge's poppet lifts to open the ② to ① flow path. In this mode, flow from ① to ② is severely restricted. If this path is required, see model SF08-22, page 1.042.1.

FEATURES

- Continuous-duty rated coil.
- Hardened seat for long life and low leakage.
- Optional coil voltages and terminations.
- Cartridges are voltage interchangeable.
- Unitized, molded coil design.
- Optional waterproof E-Coils rated up to IP69K.
- Industry common cavity.
- Compact size.

SYMBOLS

USASI:

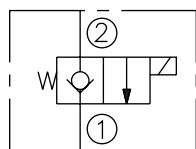

ISO:

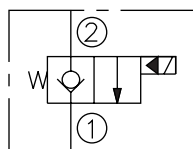

PERFORMANCE (Cartridge Only)

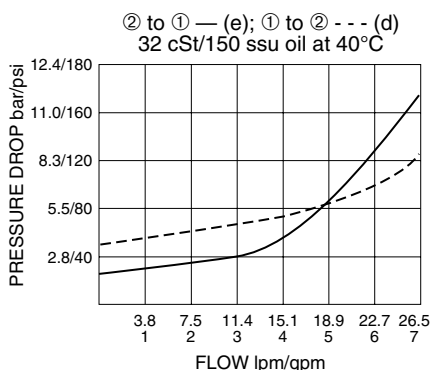

RATINGS

Operating Pressure: 345 bar (5000 psi)

Flow: See Performance Chart

Internal Leakage: 0.15 cc/minute (3 drops/minute) max. at 345 bar (5000 psi)

Temperature: -40 to 120°C with standard polyurethane seals

Coil Duty Rating: Continuous from 85% to 115% of nominal voltage

Initial Coil Current Draw at 20°C: Standard Coil: 1.2 amps at 12 VDC; 0.13 amps at 115 VAC (full wave rectified); E-Coil: 1.4 amps at 12 VDC; 0.7 amps at 24 VDC

Minimum Pull-in Voltage: 85% of nominal at 345 bar (5000 psi)

Filtration: See page 9.010.1

Fluids: Mineral-based or synthetics with lubricating properties at viscosities of 7.4 to 420 cSt (50 to 2000 ssu)

Installation: No restrictions; See page 9.020.1

Cavity: VC08-2; See page 9.108.1

Cavity Tool: CT08-2XX; See page 8.600.1

Seal Kit: SK08-2P-T; See page 8.650.1

Coil Nut: Part No. 7004400;

For E-coils manufactured prior to 1-1-04, see page 3.400.1 for coil nut info.

