

Sandwich Valve Labels & Symbols

The letters A and B stamped on the manifold indicate the side of the manifold which serves as port A and port B, relative to the valve symbol and the ISO/CETOP mounting surface.

Numbers ① and ② stamped on the manifold indicate the surface to be positioned toward the sub-base manifold surface vs. the four-way valve surface.

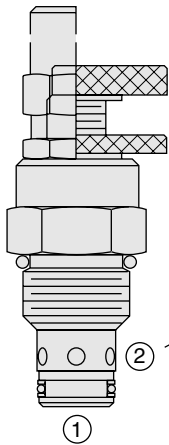
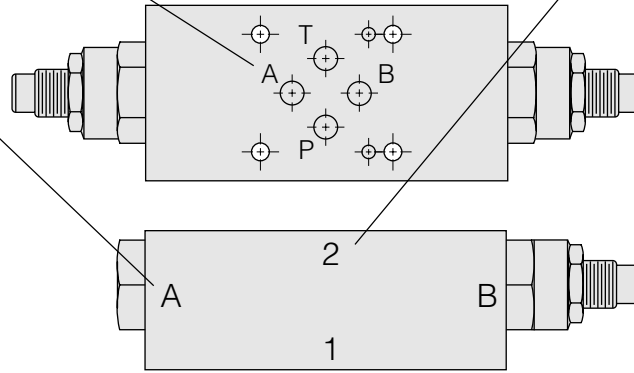
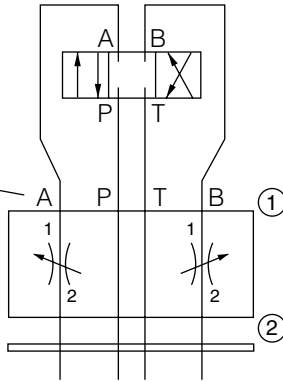

Small uncircled numbers in the valve symbol indicate the port logic of the cavity used. Individual cartridge product pages explain this port logic and labeling.

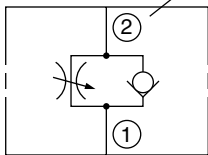
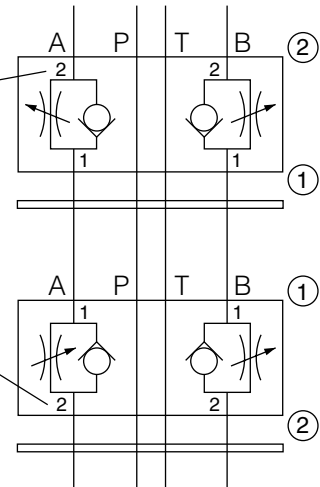

Reversible & Non-Reversible Sandwich Valves

REVERSIBLE SANDWICHES

Some sandwich valves may be flipped to reverse function direction. These require the installation of a seal plate, as no O-ring counterbores are provided on the sandwich body. When sandwich valves are ordered complete, required seal plates are automatically provided. These are indicated in the description adjacent to the symbol.

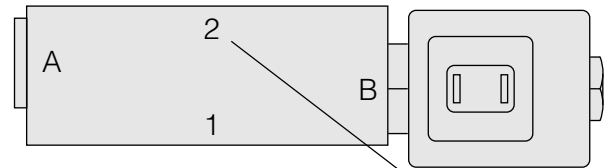

EXAMPLES:

Blocking on B, Normally Closed

Side Up: 2 Plug: 6103010
Block No.: 7170820 Plug Side: A

Model No. SV10-22-S03B-x-xx

Seal Plate: Yes
Catalog Ref.: 1.044.1

Load Holding on B, Normally Closed

Side Up: 1 Plug: 6103010
Block No.: 7170820 Plug Side: A

Model No. SV10-22-S03B-x-xx

Seal Plate: Yes
Catalog Ref.: 1.044.1

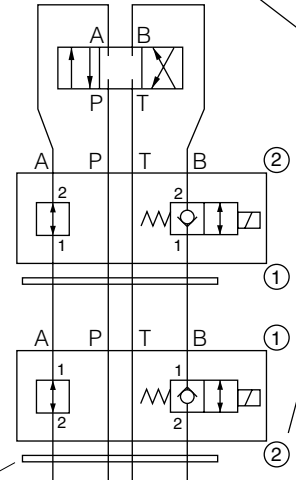

Seal plate indicated under symbol

NON-REVERSIBLE SANDWICHES

Other sandwich valves include counterbores for O-ring seals and do not require seal plates. These are indicated on the symbol and description.

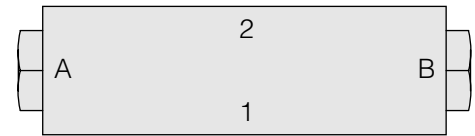

EXAMPLE:

Flow Checked Out, A Freeflow from B

Side Up: 2 Plug: CP10-20-x
Block No.: 7170810 Plug Side: B

Model No. CV10-20-S03E-x-xx

Seal Plate: No
Catalog Ref.: 4.011.1

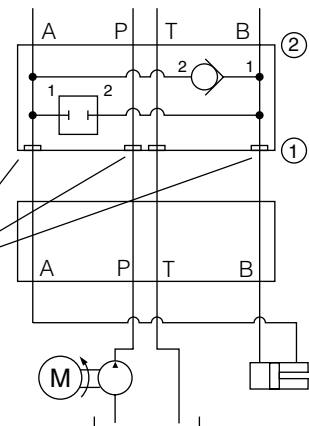

O-ring counterbores in sandwich indicated on symbol

D03 (NG6) SANDWICH VALVES

Sandwich Valve Ordering Information

TO ORDER SANDWICH VALVES COMPLETE

First, review the products available on the forthcoming pages and select the BASE MODEL NUMBER as indicated in the examples below. Note that the sandwich body code substitutes for the standard in-line body code in the same model field.

Blocking on B, Normally Closed

Side Up: 2 Plug: 6103010
Block No.: 7170820 Plug Side: A

Model No. SV10-22-S03B-x-xx

Seal Plate: Yes
Catalog Ref.: 1.044.1

Base Model No.

Catalog Ref. No.

Normally Open, Block B to A

Side Up: 2 Plug: CP10-20-x
Block No.: 7170810 Plug Side: B

Model No. SV10-23-S03F-x-xx

Seal Plate: No
Catalog Ref.: 1.053.1

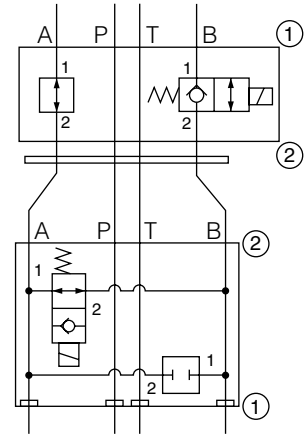

Second, once you know your BASE MODEL NO., go to the CATALOG REF. page indicated to complete the balance of the model number. Note that all fields indicated by the lower case x's must be filled in.

TO ORDER

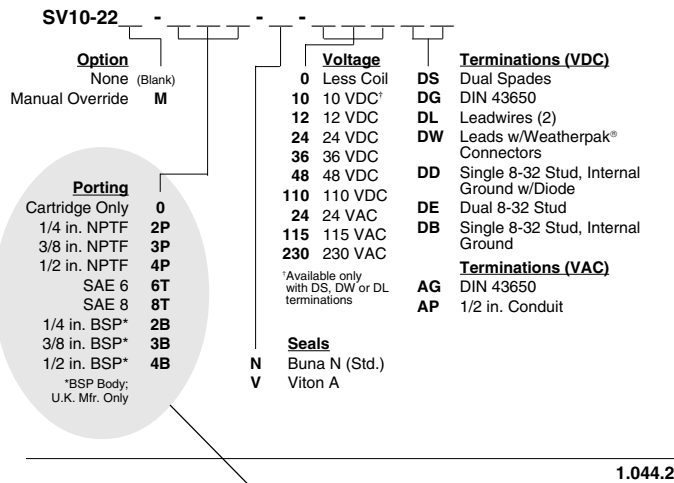

TO ORDER

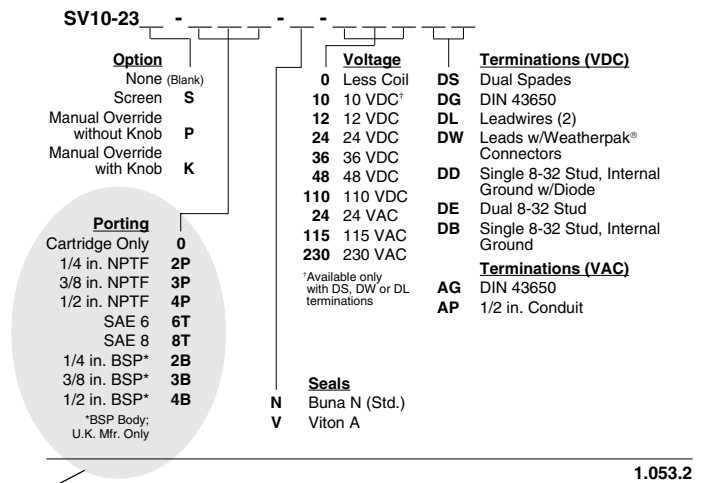

Sandwich Valve Body Code Substitutes for Porting Field

Ordering Examples (Complete Valve):

- SV10-22-S03B-N-115AG
- SV10-23-S03F-V-230AP
- CV10-20-S03E-N-5
- FC10-20A-S03A-N
- RV10-22H-S03C-NC-25/14

Sandwich Valve Ordering Information

TO ORDER SANDWICH VALVE PARTS

Standard HydraForce sandwich valves may be ordered in parts format. The base model tables indicate the parts required to complete a unit.

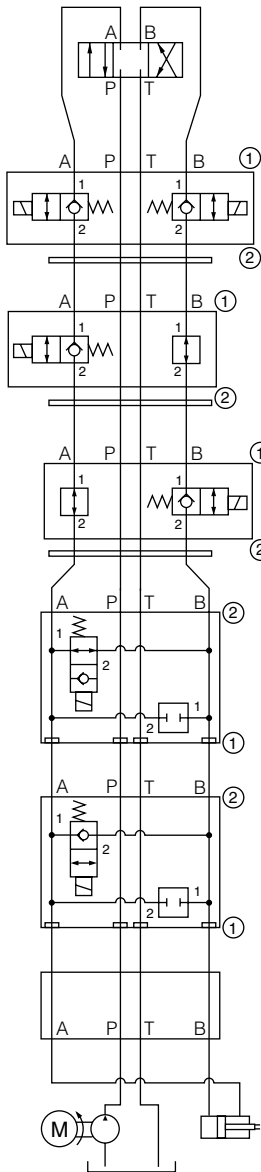

Dual Load Holding, Normally Closed

Side Up: 1 Plug: None
 Block No.: 7170820 Plug Side: n/a

Model No. SV10-22-S03D-x-xx

Seal Plate: Yes Catalog Ref.: 1.044.1

Load Holding on A, Normally Closed

Side Up: 1 Plug: 6103010
 Block No.: 7170820 Plug Side: B

Model No. SV10-22-S03A-x-xx

Seal Plate: Yes Catalog Ref.: 1.044.1

Load Holding on B, Normally Closed

Side Up: 1 Plug: 6103010
 Block No.: 7170820 Plug Side: A

Model No. SV10-22-S03B-x-xx

Seal Plate: Yes Catalog Ref.: 1.044.1

Normally Open, Block B to A Model No. SV10-23-S03F-x-xx

Side Up: 2 Plug: CP10-20-x
 Block No.: 7170810 Plug Side: B

Seal Plate: No Catalog Ref.: 1.053.1

Normally Closed, Block B to A Model No. SV10-22-S03F-x-xx

Side Up: 2 Plug: CP10-20-x
 Block No.: 7170810 Plug Side: B

Seal Plate: No Catalog Ref.: 1.044.1

The (plain) **BLOCK NO.** is referenced on each table. Note that no seals, plugs, etc. are included.

Any **PLUG** required in the block to yield the function is indicated. These might be simple SAE hex plugs (see Manifold Accessories, page 8.500.1), cavity plugs (see page 8.450.1), or special closure plugs as indicated. These plugs are offered with Buna or Fluorocarbon O-rings.

SEAL PLATES may be required. See table on page 7.800.1. If seal plates are not used, an **O-RING KIT** must be ordered. See table below.

O-RING SERVICE KITS		
Kit Part No.	O-Ring Part No.	Qty.
6299001	6001012 (Buna)	4
6299003	6003012 (Fluorocarbon)	4