

# ELECTRO-PROPORTIONAL VALVES—FLOW CONTROLS

## PFR70-33x-F Proportional Priority Flow Regulator, N.C.,

### SYMBOLS

#### USASI/ISO:

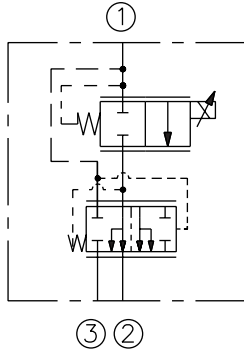

#### Attention Manifold Designers:

To obtain these high flow capabilities using proportional flow controls and compensators, optimized cavity drillings are required. Please consult factory.

### PERFORMANCE CURVES

24 Volt coil used; 130 Hz dither; PWM controller

Priority Port Flow Rate Loss Under Load  
PV70-33B with EC10-40 Typical  
11 bar/160 psi compensator —  
5.5 bar/80 psi compensator - - -  
2.8 bar/40 psi compensator •••

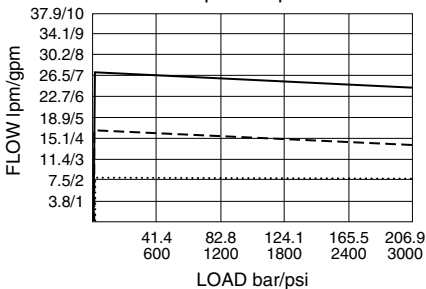

### DESCRIPTION

A pressure-compensated electrically-variable three-port flow regulator that is a priority (bypass) type control. This combination valve uses a PV70-33x proportional cartridge and an EC10-40 compensator.

### OPERATION

The PFR70-33x-F series will bypass all flow out port ③ when de-energized at the pressure compensator spring value. When energized, this proportional valve/compensator package will increase and regulate flow out of port ②, regardless of system working pressure, with an increasing current applied to the solenoid.

### FEATURES

- Excellent linearity and hysteresis characteristics.
- Optional control orifice sizes.
- Hardened spool and cage for long life.
- Optional coil voltages and terminations.
- Efficient wet armature construction.
- Cartridges voltage interchangeable.
- Unitized, molded coil design.
- Coil waterproofing standard.
- Screw-in manual override option.

### RATINGS

**Operating Pressure:** 207 bar (3000 psi)

**Pressure Rise:** Pressure at ① begins to rise higher than the compensating pressure differential when bypass flow exceeds 26.5 lpm (7 gpm).

**Internal Leakage:** 410 cc/min. (25 cu. in./min.) fully closed at 207 bar (3000 psi) out port ②.

**Electrical:** 2 standard voltage ratings

Coil Voltage	Threshold Current (mA)		Max. Control Current (mA)	
	A & B Range	C Range	A & B Range	C Range
12 VDC	300 ± 70	360 ± 70	1500 ± 200	1400 ± 200
24 VDC	150 ± 35	180 ± 35	750 ± 100	700 ± 100

#### Operation of Manual Override:

To Engage: Turn clockwise approximately 1 turn to reach start point. Continue another approximately 5 turns to full shift.

To Disengage: Turn counterclockwise approximately 6 turns until positive stop is found.

**Filtration:** See page 9.010.1

**Fluids:** Mineral-based or synthetics with lubricating properties at viscosities of 7.4 to 420 cSt (50 to 2000 ssu)

**Installation:** No restrictions; See page 9.020.1

### Priority Port Flow Delivered Out Port ②:

For 12 volt coils, double the current (amp) values shown.

Flow vs. Current (207 bar/3000 psi Load)  
PV70-33A with EC10-40  
11 bar/160 psi spring —  
5.5 bar/80 psi spring - - -  
2.8 bar/40 psi spring •••••  
100 Hz Dither

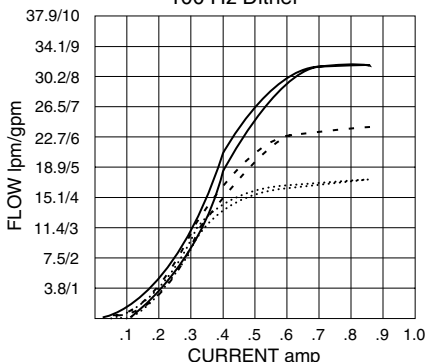

Flow vs. Current (207 bar/3000 psi Load)  
PV70-33B with EC10-40  
11 bar/160 psi spring —  
5.5 bar/80 psi spring - - -  
2.8 bar/40 psi spring •••••  
100 Hz Dither

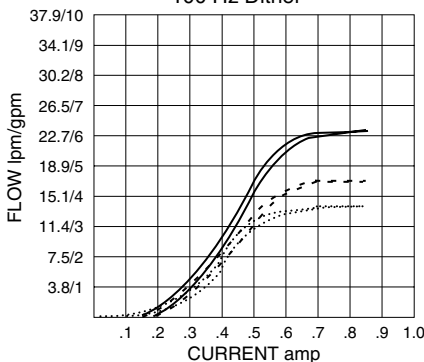

Flow vs. Current (207 bar/3000 psi Load)  
PV70-33C with EC10-40  
11 bar/160 psi spring —  
5.5 bar/80 psi spring - - -  
2.8 bar/40 psi spring •••••  
100 Hz Dither

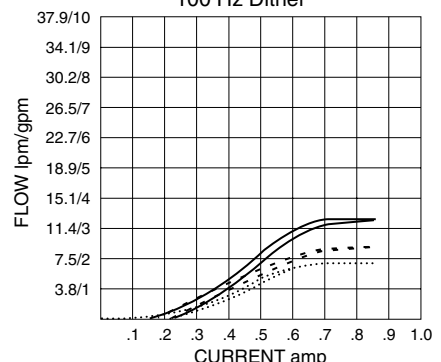

# 3-Port, Pressure Compensated

# PFR70-33x-F

## DIMENSIONS

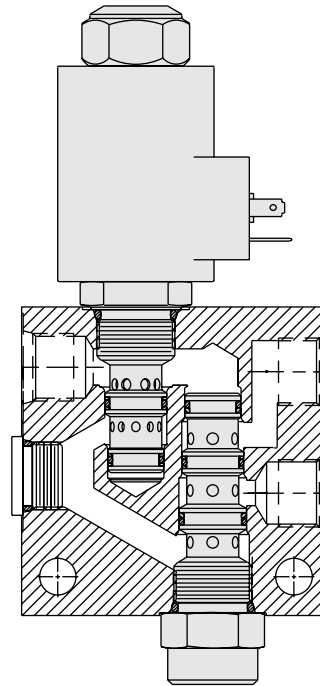
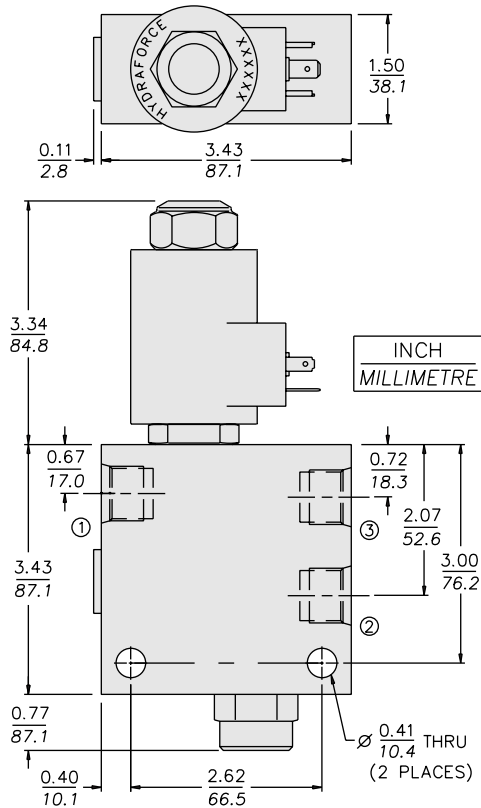

**NOTE:** The N.O. PV70-35 may not be substituted in this manifold due to port logic factors.

## MATERIALS

**Cartridge:** Steel with hardened work surfaces. Zinc-plated exposed surfaces. Buna N O-rings and back-ups standard.

**Standard Ported Body:** Anodized high-strength 6061 T6 aluminum alloy, rated to 240 bar (3500 psi). Ductile iron and steel bodies available; dimensions may differ; consult factory.

**Coil:** Unitized thermoplastic encapsulated, Class H high temperature magnetwire; See page 3.200.1.

**Package Weight:** 2.27 kg. (5 lbs.).

**Seal Kit:** SK10-3X-MM (PV); SK10-4X-TMB (EC)

## TO ORDER

PFR70-33 - F - 8T - - - - -

### \*PV Orifice Range

Orifice Range **A**  
Orifice Range **B**  
Orifice Range **C**

### Override Option

(Blank) None  
**M** Screw Type

### \*Compensator Spring

2.76 bar (40 psi) **40**  
5.52 bar (80 psi) **80**  
11.03 bar (160 psi) **160**

### Terminations

**DS** Dual Spades  
**DG** DIN 43650  
**DL** Leadwires (2)  
**DL/W** Leads w/Weatherpak® Connectors  
**DR** Deutsch DT04-2P

### Seals

Buna N (Std.) **N**  
Fluorocarbon **V**

### Voltage

**0** Less Coil  
**12** 12 VDC  
**24** 24 VDC

\*Select Orifice Range and Compensator Spring by referring to the Performance Curves on the preceding page.

Coils with internal diode are available. Consult factory.