

ELECTRO-PROPORTIONAL VALVES—FLOW CONTROLS

PV76-31 Proportional Flow Control Cartridge,

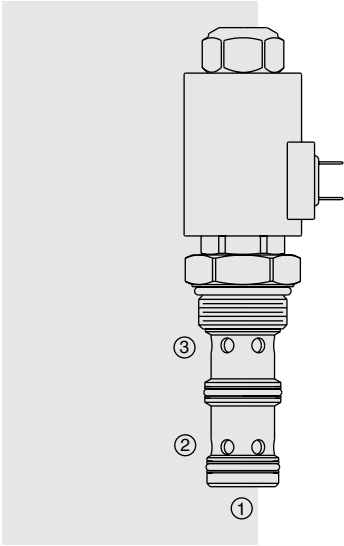

DESCRIPTION

A solenoid-operated, electrically-variable, three-port, pressure-compensated, spool-type, normally open when de-energized, proportional flow control valve. It can be used as a priority-type flow regulator with pressure-compensated, regulated and bypass flow. It can also be used as a restrictive-type 2-way, pressure-compensated flow regulator when the bypass line (port ②) is blocked.

OPERATION

The PV76-31 will regulate flow out of port ③ regardless of system working pressure. With an increasing current applied to the solenoid, output flow will decrease.

Note: When used as a bypass flow control in applications where the priority flow port will be blocked by external valving, bypass pressure drop will increase unless a small amount of leakage is provided for the priority port. Consult factory.

Operation of Manual Override: To Engage: Turn clockwise approximately 1 turn to reach start point. Continue another approximately 5 turns to full shift. To Disengage: Turn counterclockwise approximately 6 turns to positive stop.

FEATURES

- Excellent linearity and hysteresis characteristics.
- Hardened spool and cage for long life.
- Optional coil voltages and terminations.
- Efficient wet armature construction.

SYMBOLS

USASI/ISO:

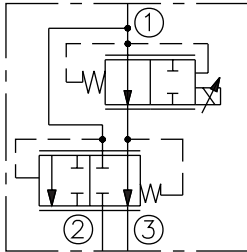

RATINGS

Operating Pressure: Inlet: 240 bar (3500 psi); Ports ② and ③: 207 bar (3000 psi)

Regulated Flow Rate: 3-Ported: 75.7 lpm (20.0 gpm)
2-Ported: 79.5 lpm (21.0 gpm)

Maximum Input Flow: Bypass Open, 3-Ported: 151.4 lpm (40.0 gpm)

Internal Leakage: 0.38 lpm (0.10 gpm) at maximum current

Electrical: 2 standard voltage ratings

Coil Voltage	Threshold Current	Max. Control Current
12 VDC	100 ± 50 mA	1500 ± 100 mA
24 VDC	50 ± 25 mA	750 ± 50 mA

Filtration: See page 9.010.1

Fluids: Mineral-based or synthetics with lubricating properties at viscosities of 7.4 to 420 cSt (50 to 2000 ssu)

Installation: No restrictions; See page 9.020.1.

Cavity: VC16-3; See page 9.116.1; **Cavity Tool:** CT16-3X-XX; See page 8.600.1

Seal Kit: SK16-3X-MM; See page 8.650.1

PERFORMANCE

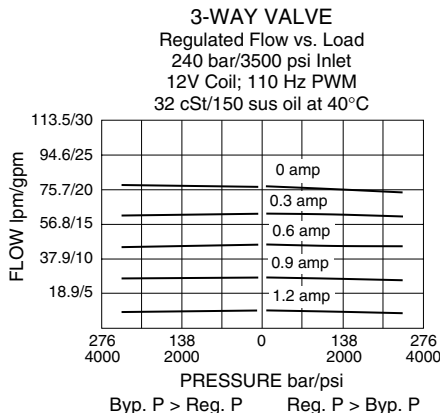
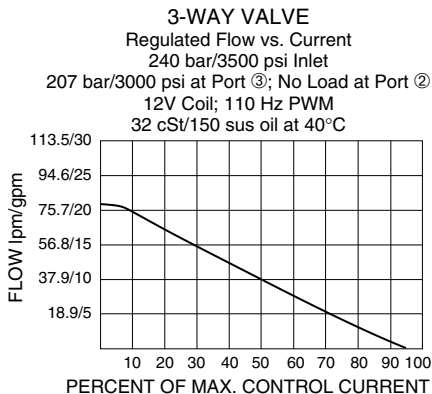

Recommended Controllers (See Section 3)

Input Sig. w/12V Coil	DIN Coil Mount	PCB Board	Metal Box	DIN Rail Mount
0-5 VDC	7114950	4000046	4000049	4000136
0-10 VDC	4000070	4000141	4000124	4000137
4-20 mA PWM	4000123	4000143	4000130	4000139
	—	4000144	4000133	4000140
w/24V Coil				
0-5 VDC	4000161	4000194	4000174	4000136
0-10 VDC	4000165	4000141	4000182	4000137
4-20 mA PWM	4000169	4000143	4000186	4000139
	—	4000144	4000133	4000140

Normally Open

PV76-31

PERFORMANCE (continued)

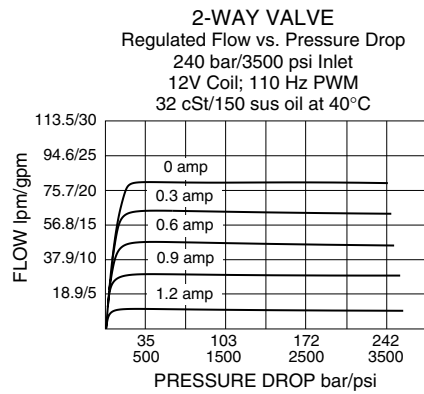
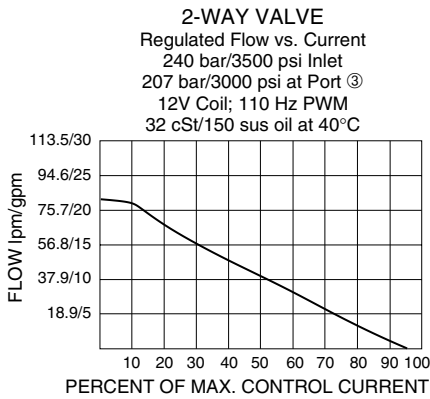

DIMENSIONS

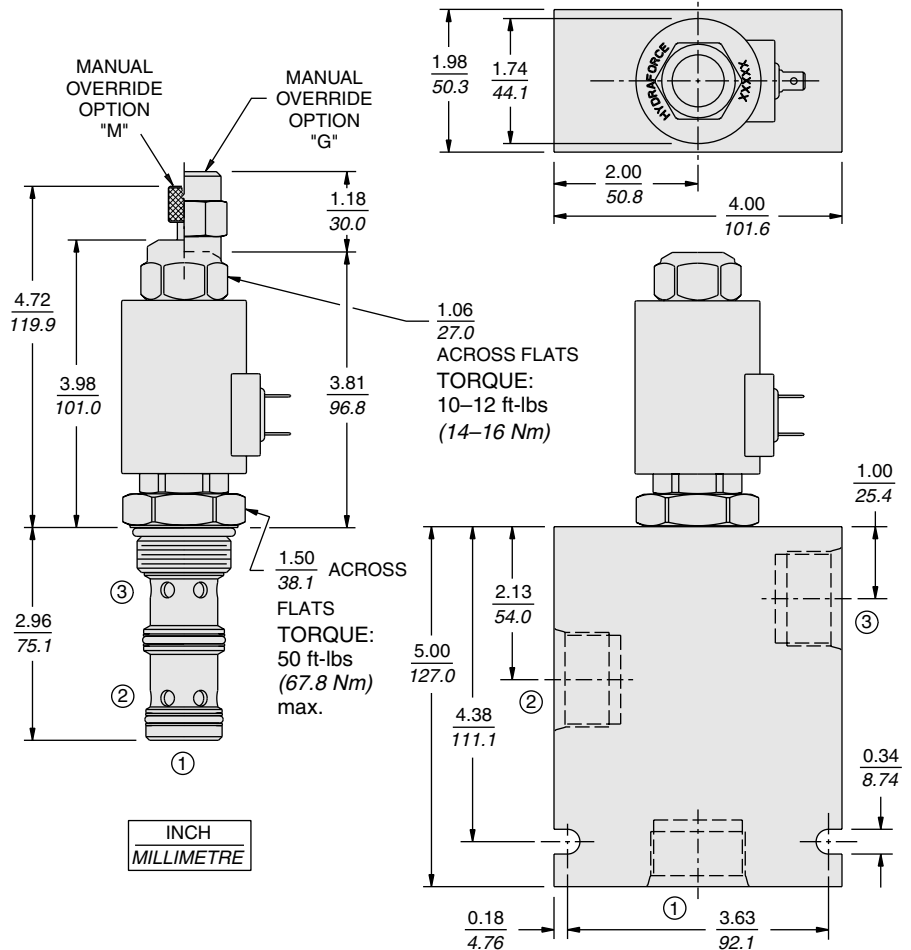

MATERIALS

Cartridge: Weight: 0.54 kg. (1.19 lbs.); Steel with hardened work surfaces. Zinc-plated exposed surfaces. Buna N O-rings and polyester elastomer back-ups standard.

Standard Ported Body: Weight: 1.6 kg. (3.35 lbs.); Anodized high-strength 6061 T6 aluminum alloy, rated to 240 bar (3500 psi); See page 8.016.1. Steel and Ductile Iron bodies available; dimensions may differ; consult factory.

PV70 Series Coil: Weight: 0.32 kg. (0.7 lbs.); Unitized thermoplastic encapsulated, Class H high temperature magnet-wire; See page 3.200.7.

TO ORDER

