

ELECTRO-PROPORTIONAL VALVES—DIRECTIONAL CONTROL

SP08-21 Poppet, 2-Way, Normally Open

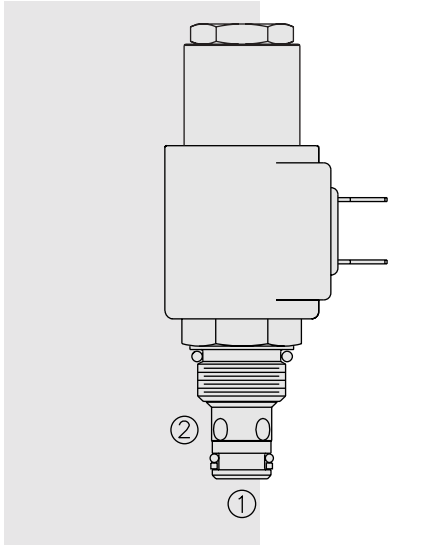

DESCRIPTION

A proportional solenoid-operated, 2-way, poppet-type, normally open, screw-in hydraulic cartridge valve for low-leakage load-holding applications and for starting or stopping a load or a pump system..

OPERATION

When de-energized, the **SP08-21** allows flow from ② to ①. When the valve is partially energized, the valve begins to throttle the flow from ② to ①. When fully energized, the poppet closes on the seat, blocking flow from ② to ①. Flow from ① to ② will occur when hydraulic pressure exceeds the solenoid force.

Note: If low voltage is expected on the machine, 12 or 24 volt systems will require the use of 10 volt or 20 volt coils respectively. See “SP Valves and Coil Operating Parameters,” page 2.002.1.

FEATURES

- Industry-common cavity.
- Efficient wet-armature construction.
- Continuous-duty rated coils.
- Optional waterproof E-Coils rated up to IP69K.

RATINGS

Operating Pressure: 207 bar (3000 psi)

Operating Voltage: See Performance Chart

Flow: 0 to 22.7 lpm (0 to 6 gpm)

Max. Internal Leakage: 5 drops per minute at 207 bar (3000 psi)

Temperature: -40 to 120°C with standard Buna seals

Filtration: See page 9.010.1

Fluids: Mineral-based or synthetics with lubricating properties at viscosities of 7.4 to 420 cSt (50 to 2000 sus)

Installation: No Restrictions. See page 9.020.1

Cavity: VC08-2; See page 9.108.1; **Cavity Tool:** CT08-2XX; See page 8.600.1

Seal Kit: SK08-2X-T; See page 8.650.1

Coil Nut: Part No. 7004400;

For E-coils manufactured prior to 1-1-04, see page 3.400.1 for coil nut info.

SYMBOLS

USASI/ISO:

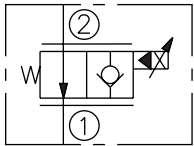

PERFORMANCE

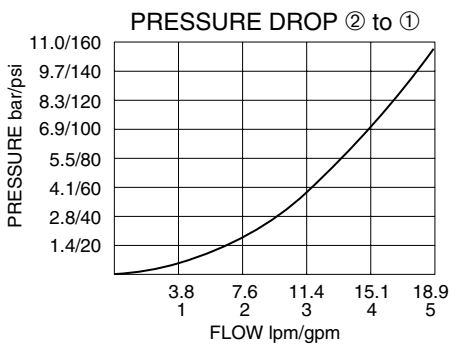

Recommended Controllers (See Section 3)

Input Sig. w/12V Coil	DIN Coil Mount	PCB Board	Metal Box	DIN Rail Mount
0-5 VDC	7114950	4000046	4000049	4000136
0-10 VDC	4000070	4000141	4000124	4000137
4-20 mA	4000123	4000143	4000130	4000139
PWM	—	4000144	4000133	4000140
w/24V Coil				
0-5 VDC	4000161	4000194	4000174	4000136
0-10 VDC	4000165	4000141	4000182	4000137
4-20 mA	4000169	4000143	4000186	4000139
PWM	—	4000144	4000133	4000140

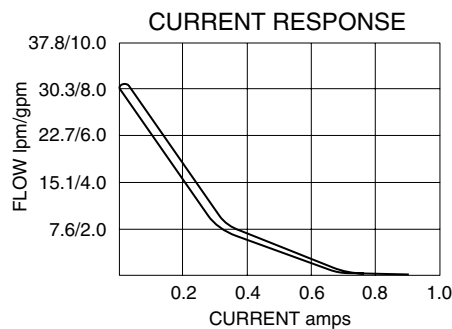
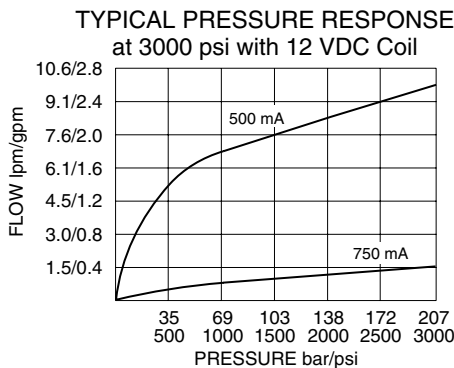

Note: Electronic Controller is required to ramp current.

DIMENSIONS

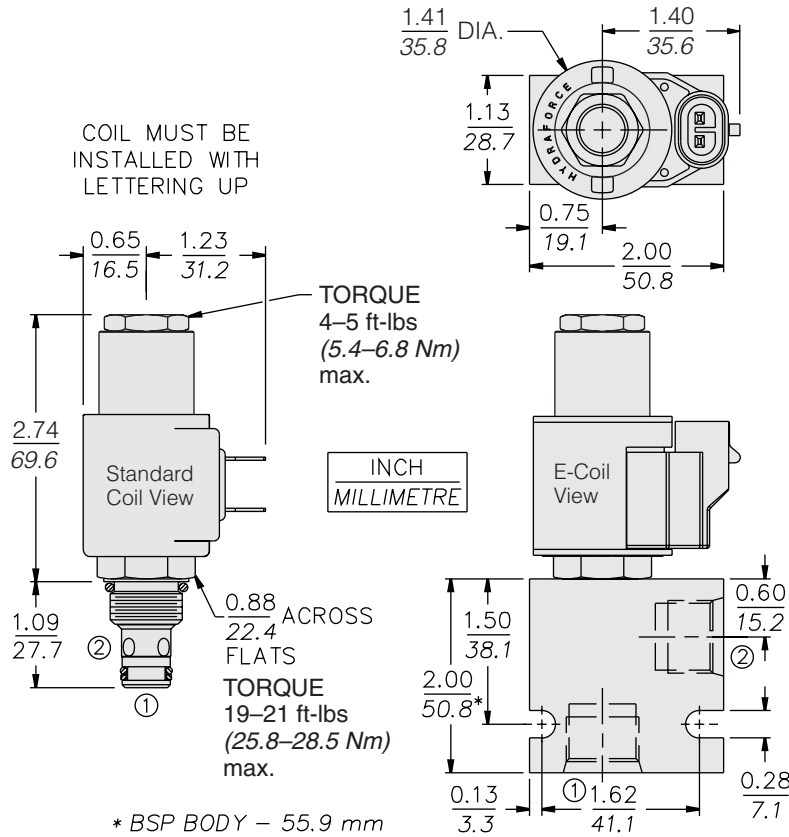

MATERIALS

Cartridge: Weight: 0.11 kg. (0.25 lbs.); Steel with hardened work surfaces. Zinc-plated exposed surfaces; Buna N O-rings and back-ups standard.

Standard Ported Body: Weight: 0.16 kg. (0.35 lbs.); Anodized high-strength 6061 T6 aluminum alloy, rated to 240 bar (3500 psi); See page 8.008.1. Ductile iron and steel bodies available; dimensions may differ; consult factory.

Standard Coil: Weight: 0.11 kg. (0.25 lbs.); Unitized thermoplastic encapsulated, Class H high temperature magnetwire; See page 3.200.1.

E-Coil: Weight: 0.14 kg. (0.3 lbs.); Perfect wound, fully encapsulated with rugged external metal shell; Rated up to IP69K with integral connectors.

TO ORDER

