

# PRESSURE CONTROLS

## PS10-34 Sequence, Internal Pilot & Drain

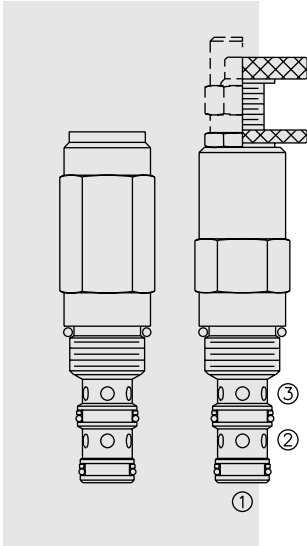

### DESCRIPTION

A screw-in, cartridge-style, direct-acting, spool-type, hydraulic sequence valve with internal pilot and spring chamber drain.

### OPERATION

In its steady state, the **PS10-34** blocks flow from ① to ②, with the spring chamber drained at ③.

On attainment of a predetermined pressure at ①, the cartridge shifts to open ① to ②.

Note that back-pressure on ③ adds to the spring setting value.

### FEATURES

- Adjustments cannot be backed out of the valve.
- Adjustments prohibit springs from going solid.
- Optional spring ranges to 117.2 bar (1700 psi).
- Hardened spool and cage for long life.
- Industry common cavity.

### RATINGS

**Operating Pressure:** to 207 bar (3000 psi)

**Sequence Pressure Max.:** to 117 bar (1700 psi)

**Flow:** See Performance Chart

**Internal Leakage:** 82 cc/minute (5 cu. in./minute) max. to 85% of nominal setting

**Standard Spring Ranges:**

6.9 to 48.3 bar (100 to 700 psi);

20.7 to 117.2 bar (300 to 1700 psi)

**Temperature:** -40 to 120°C with standard Buna seals

**Filtration:** See page 9.010.1

**Fluids:** Mineral-based or synthetics with lubricating properties at viscosities of 7.4 to 420 cSt (50 to 2000 ssu)

**Installation:** No restrictions; See page 9.020.1

**Cavity:** VC10-3; See page 9.110.1

**Cavity Tool:** CT10-3XX; See page 8.600.1

**Seal Kit:** SK10-3X-BM; See page 8.650.1

### SYMBOLS

#### USASI/ISO:

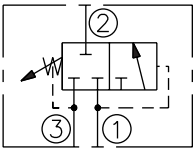

### PERFORMANCE (Cartridge Only)

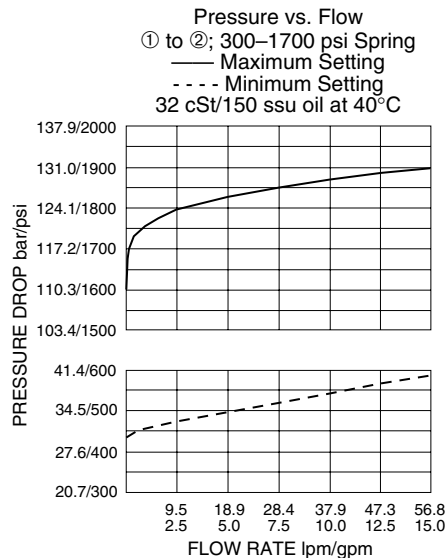
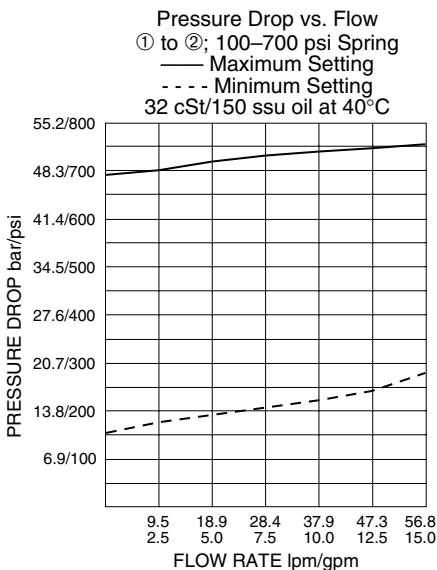

# PS10-34

## DIMENSIONS

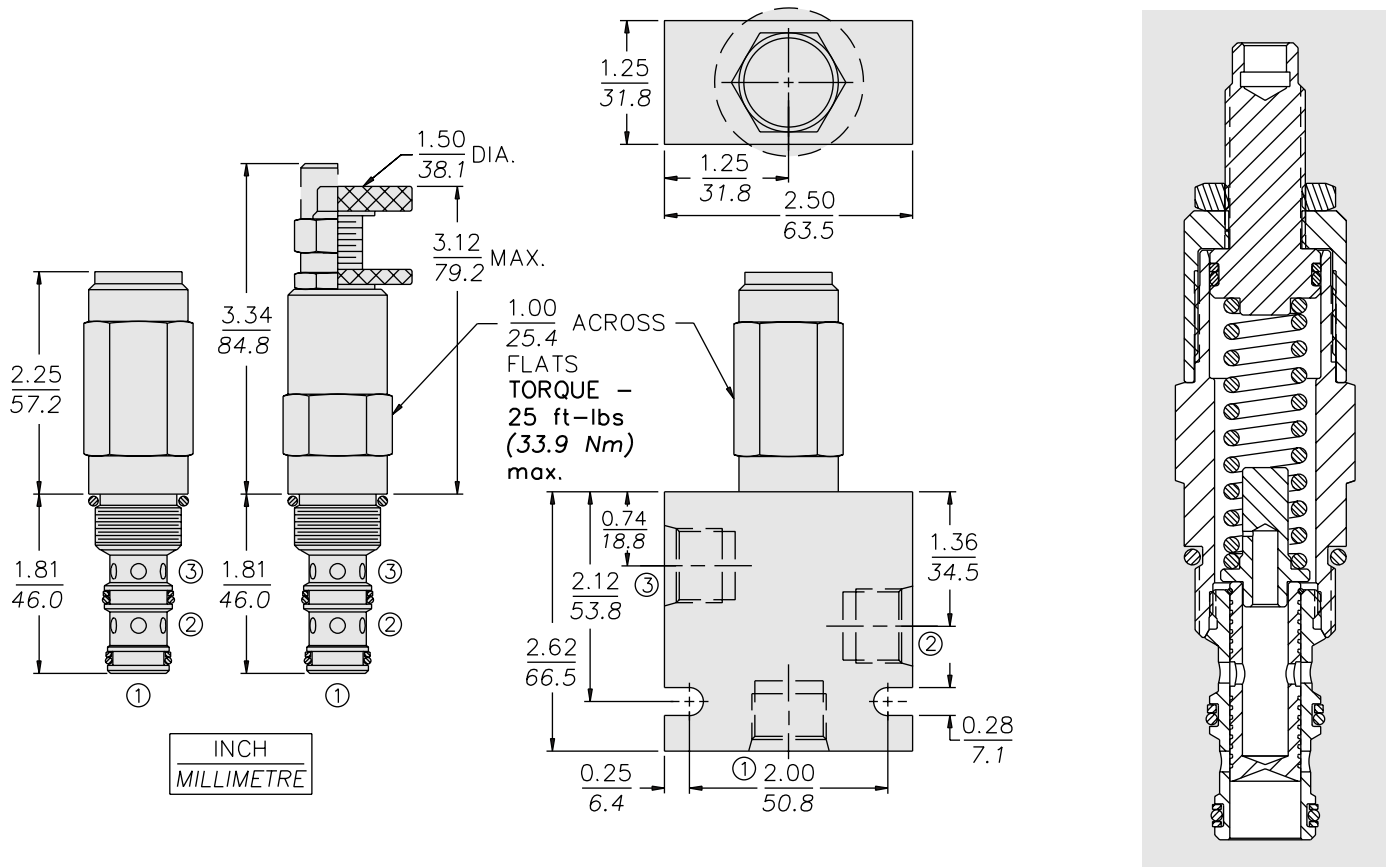

## MATERIALS

**Cartridge:** Weight: 0.27 kg. (0.60 lbs.); Steel with hardened work surfaces. Zinc-plated exposed surfaces. Buna N O-rings and polyester elastomer back-ups standard. Anodized aluminum knobs and caps.

**Standard Ported Body:** Weight: 0.36 kg. (0.80 lbs.); Anodized high-strength 6061 T6 aluminum alloy, rated to 240 bar (3500 psi); See page 8.010.1. Ductile iron and steel bodies available; dimensions may differ; consult factory.

## TO ORDER

### PS10-34

#### Adjustment Option

- 1/4 in. Hex Allen Head **A**
- 1-1/2 in. Dia. Alum Knob **B**
- Option A w/Cover Cap **C**
- Factory Preset Non-Adj. **F**
- Factory Preset Hidden Adj. **H**
- Option C w/ Lockwire Holes **L**

#### Porting

- Cartridge Only **0**
- SAE 6 **6T**
- SAE 8 **8T**
- 1/4 in. BSP\* **2B**
- 3/8 in. BSP\* **3B**

\*BSP Body; U.K. Mfr. Only

#### Seals

- Buna N (Std.) **N**
- Fluorocarbon **V**

#### Setting in bars<sup>†</sup>

- (Blank) for Adjustable, or Specify, for example:
- M25** 25 bar
- M100** 100 bar

#### Setting in psi<sup>†</sup>

- (Blank) for Adjustable, or Specify, for example:
- 9.0** 900 psi
- 16.0** 1600 psi

#### Spring Range

- 7** 6.9 to 48.3 bar (100 to 700 psi)
- 17** 20.7 to 117.2 bar (300 to 1700 psi)

<sup>†</sup>Adjustable valves will be preset to approx. 50% of spring max. potential.