

PRESSURE CONTROLS

PS08-30 Sequence, Internal Pilot & Drain

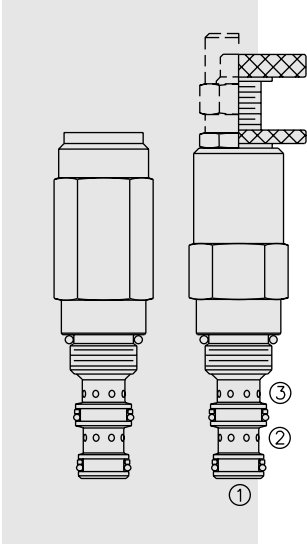

DESCRIPTION

A screw-in, cartridge-style, direct-acting, spool-type, hydraulic sequence valve with internal pilot and spring chamber drain, designed to direct oil to a secondary circuit once a pre-determined pressure level is attained in the primary circuit.

OPERATION

In its steady state, the **PS08-30** blocks flow at ①, while allowing flow to pass from ② to ③.

On attainment of a pre-determined pressure at ①, the cartridge shifts to open ① to ②.

FEATURES

- Adjustments cannot be backed out of the valve.
- Adjustments prohibit springs from going solid.
- Optional spring ranges to 165.5 bar (2400 psi).
- Hardened spool and cage for long life.
- Compact size.

RATINGS

Operating Pressure: 240 bar (3500 psi)

Flow: See Performance Chart

Internal Leakage: 82 cc/minute (5 cu. in./minute) max. to 90% of nominal setting

Standard Spring Ranges:

- 3.4 to 20.7 bar (50 to 300 psi);
- 6.9 to 41.4 bar (100 to 600 psi);
- 10.3 to 89.7 bar (150 to 1300 psi);
- 31.0 to 165.5 bar (450 to 2400 psi)

Temperature: -40 to 120°C with standard Buna seals

Filtration: See page 9.010.1

Fluids: Mineral-based or synthetics with lubricating properties at viscosities of 7.4 to 420 cSt (50 to 2000 ssu)

Installation: No restrictions; See page 9.020.1

Cavity: VC08-3; See page 9.108.1

Cavity Tool: CT08-3XX; See page 8.600.1

Seal Kit: SK08-3X-BB; See page 8.650.1

SYMBOLS

USASI/ISO:

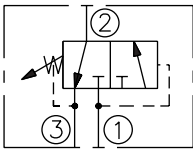

PERFORMANCE (Cartridge Only)

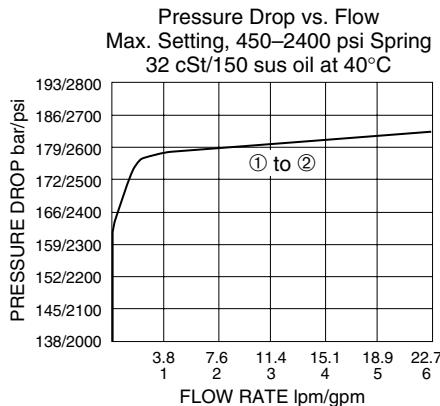
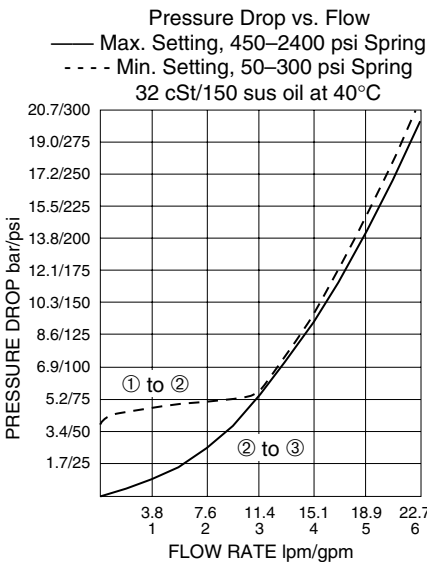

DIMENSIONS

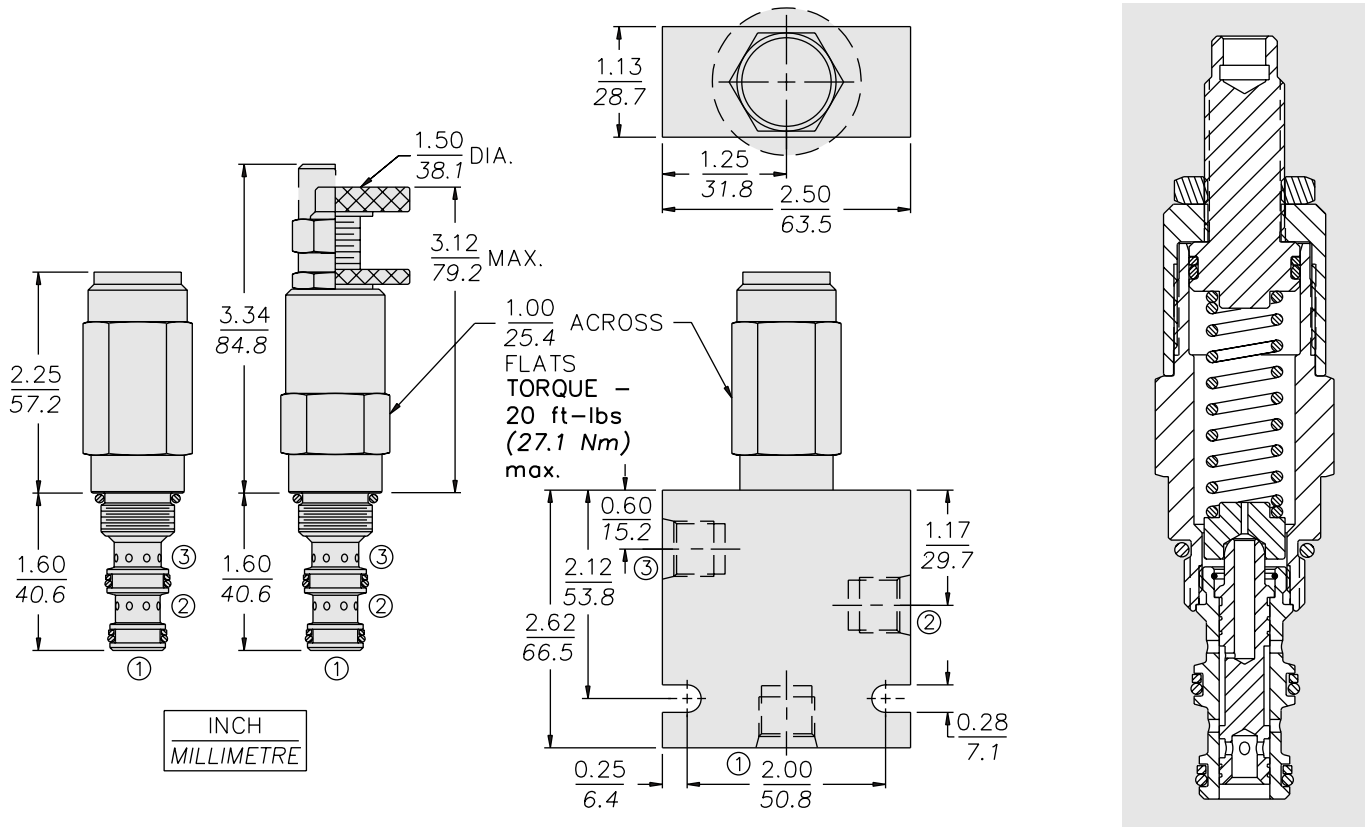

MATERIALS

Cartridge: Weight: 0.25 kg. (0.55 lbs.); Steel with hardened work surfaces. Zinc-plated exposed surfaces. Buna N O-rings and back-ups standard. Anodized aluminum knobs.

Standard Ported Body: Weight: 0.27 kg. (0.60 lbs.); Anodized high-strength 6061 T6 aluminum alloy, rated to 240 bar (3500 psi); see page 8.008.1. Ductile iron and steel bodies available; dimensions may differ; consult factory.

TO ORDER

PS08-30 - - - /

Adjustment Option

- 1/4 in. Hex Allen Head **A**
- 1-1/2 in. Dia. Alum Knob **B**
- Option A w/Cover Cap **C**
- Factory Preset Non-Adj. **F**
- Factory Preset Hidden Adj. **H**
- (See page 6.003.1)
- Option C w/ Lockwire Holes **L**

Porting

- Cartridge Only **0**
- SAE 4 **4T**
- SAE 6 **6T**
- 3/8 in. BSP* **3B**

*BSP Body; U.K. Mfr. Only

Seals

- Buna N (Std.) **N**
- Fluorocarbon **V**

Setting in bar[†]

- (Blank) for Adjustable, or Specify, for example:
- M25** 25 bar
- M100** 100 bar
- Setting in psi[†]**
- (Blank) for Adjustable, or Specify, for example:
- 9.0** 900 psi
- 23.5** 2350 psi

Spring Range

- 3** 3.4 to 20.7 bar (50 to 300 psi)
- 6** 6.9 to 41.4 bar (100 to 600 psi)
- 13** 10.3 to 89.7 bar (150 to 1300 psi)
- 24** 31.0 to 165.5 bar (450 to 2400 psi)

[†]Adjustable valves will be preset to approx. 50% of spring max. potential.