

PRESSURE CONTROLS

ER10-S30 Pressure Reducing Spool Logic Element

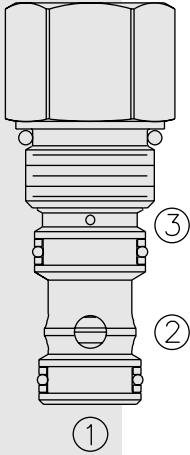

DESCRIPTION

A screw-in, cartridge-style, spring biased, pressure reducing logic element.

OPERATION

In its steady state, the **ER10-S30** allows flow from ② to ① with the spring chamber constantly drained at ③. On attainment of a pre-determined pressure at ①, set by a (remote) pilot relief valve connected to port ③, the spool shifts to restrict input flow at ②, thereby regulating pressure at ①.

FEATURES

- Adjustments cannot be backed out of the valve.
- Adjustments prohibit springs from going solid.
- Optional spring ranges to 207 bar (3000 psi).
- Hardened spool and cage for long life.
- Industry common cavity.

RATINGS

Operating Pressure: 350 bar (5000 psi); Polyurethane seals are recommended for 5000 psi operation; Aluminum bodies for this product are rated at 3500 psi

Proof Pressure: 390 bar (5700 psi)

Flow: See Performance Chart

Maximum Pilot Flow: 5.3 lpm (1.4 gpm)

Bias Spring: 5.5 bar (80 psi)

Temperature: -40 to 120°C with standard Buna seals

Filtration: See page 9.010.1

Fluids: Mineral-based or synthetics with lubricating properties at viscosities of 7.4 to 420 cSt (50 to 2000 ssu)

Installation: No restrictions; See page 9.020.1

Cavity: VC10-S3; See page 9.110.1

Cavity Tool: CT10-S3XX; See page 8.600.1

Seal Kit: SK10-3X-BM; See page 8.650.1

SYMBOLS

USASI/ISO:

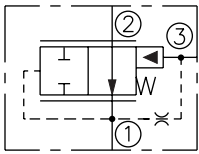

PERFORMANCE (Cartridge Only)

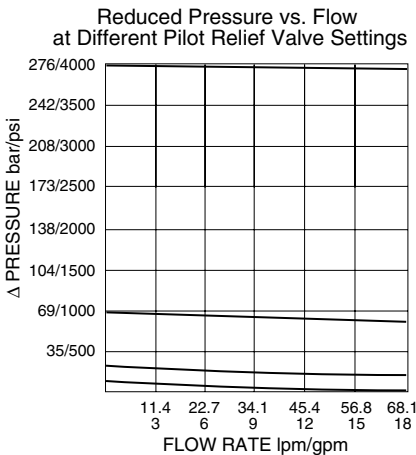
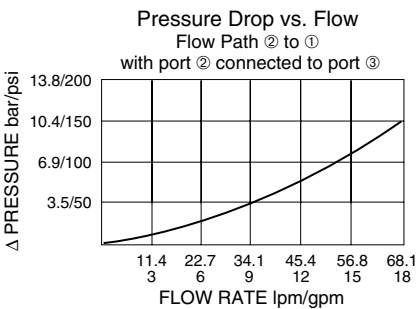

ER10-S30

DIMENSIONS

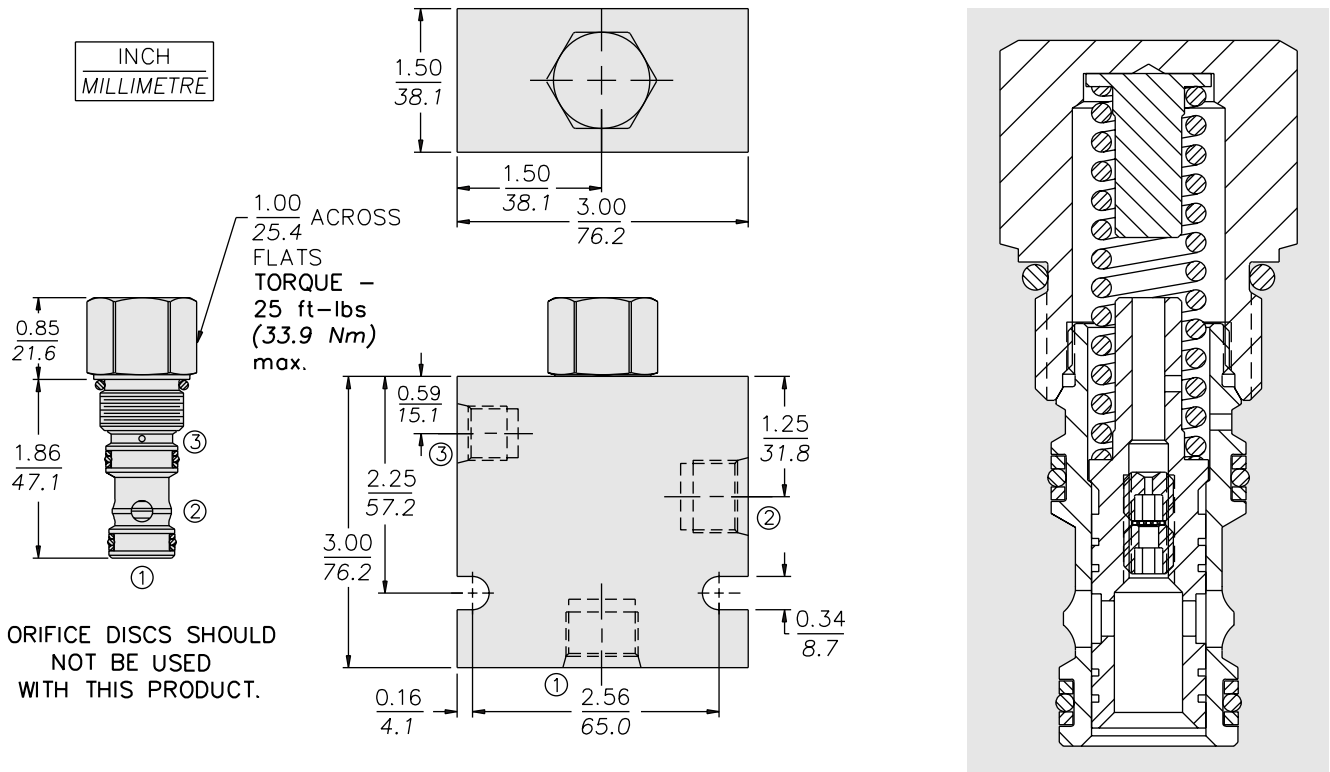

MATERIALS

Cartridge: Weight: 0.27 kg. (0.60 lbs.); Steel with hardened work surfaces. Zinc-plated exposed surfaces. Buna N O-rings and polyester elastomer back-ups standard.

Standard Ported Body: Weight: 0.36 kg. (0.80 lbs.); Anodized high-strength 6061 T6 aluminum alloy, rated to 240 bar (3500 psi); see page 8.010.1. Ductile iron and steel bodies available; dimensions may differ; consult factory.

TO ORDER

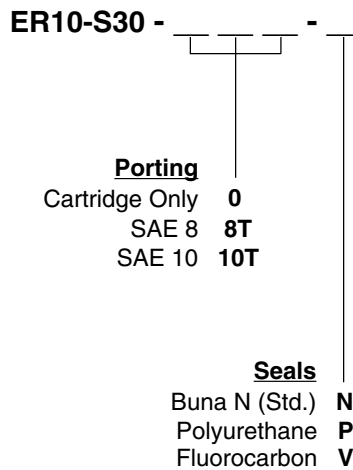

Note: Polyurethane seals are recommended for operation over 241 bar (3500 psi)