

PR10-32 Pressure Reducing/Relieving

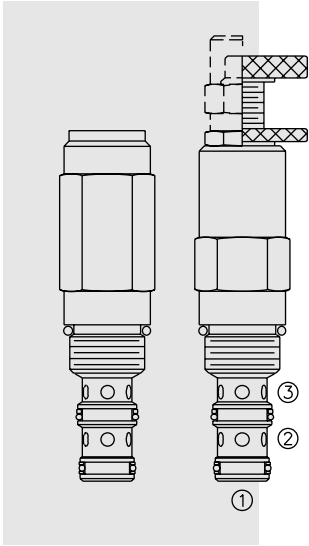

DESCRIPTION

A screw-in, cartridge-style, direct-acting, spool-type, hydraulic pressure reducing/relieving valve with internal pilot and internal spring chamber drain, designed to act as a pressure-regulating device for secondary circuits. It is intended for use in stable input flow circuits.

OPERATION

In its steady state, the **PR10-32** allows flow to pass bidirectionally from ② to ①, with the spring chamber constantly drained at ③.

On attainment of a pre-determined pressure at ①, the cartridge shifts to restrict input flow at ②, thereby regulating pressure at ①. In this mode, the valve will also relieve ① to ③ at approximately 10 bar (150 psi) over the reducing setting.

Note: Direct-acting PR series valves may not be suitable for some static load applications. Consult factory.

FEATURES

- Adjustments cannot be backed out of the valve.
- Adjustments prohibit springs from going solid.
- Optional spring ranges to 145 bar (2100 psi).
- Hardened spool and cage for long life.
- Industry common cavity.

SYMBOLS

USASI/ISO:

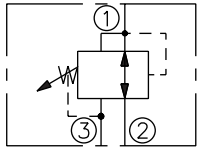

RATINGS

Operating Pressure: 207 bar (3000 psi)

Flow: See Performance Chart

Internal Leakage ② to ③: 82 cc/minute (5 cu. in/minute) max. at ΔP 207 bar (3000 psi)

Standard Spring Ranges (Reducing Function):

- 5.5 to 27.6 bar (80 to 400 psi)
- 13.8 to 55.2 bar (200 to 800 psi)
- 20.7 to 103 bar (300 to 1500 psi)
- 27.6 to 145 bar (400 to 2100 psi)

Temperature: -40 to 120°C with standard Buna seals

Filtration: See page 9.010.1

Fluids: Mineral-based or synthetics with lubricating properties at viscosities of 7.4 to 420 cSt (50 to 2000 ssu)

Installation: No restrictions; See page 9.020.1

Cavity: VC10-3; See page 9.110.1

Cavity Tool: CT10-3XX; See page 8.600.1

Seal Kit: SK10-3X-BM; See page 8.650.1

PERFORMANCE (Cartridge Only)

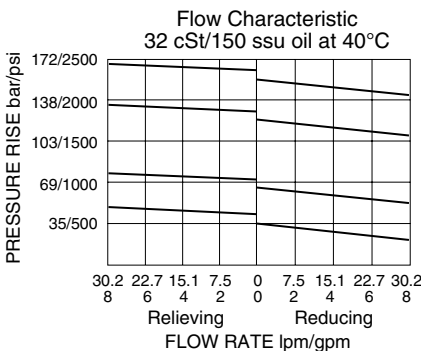

DIMENSIONS

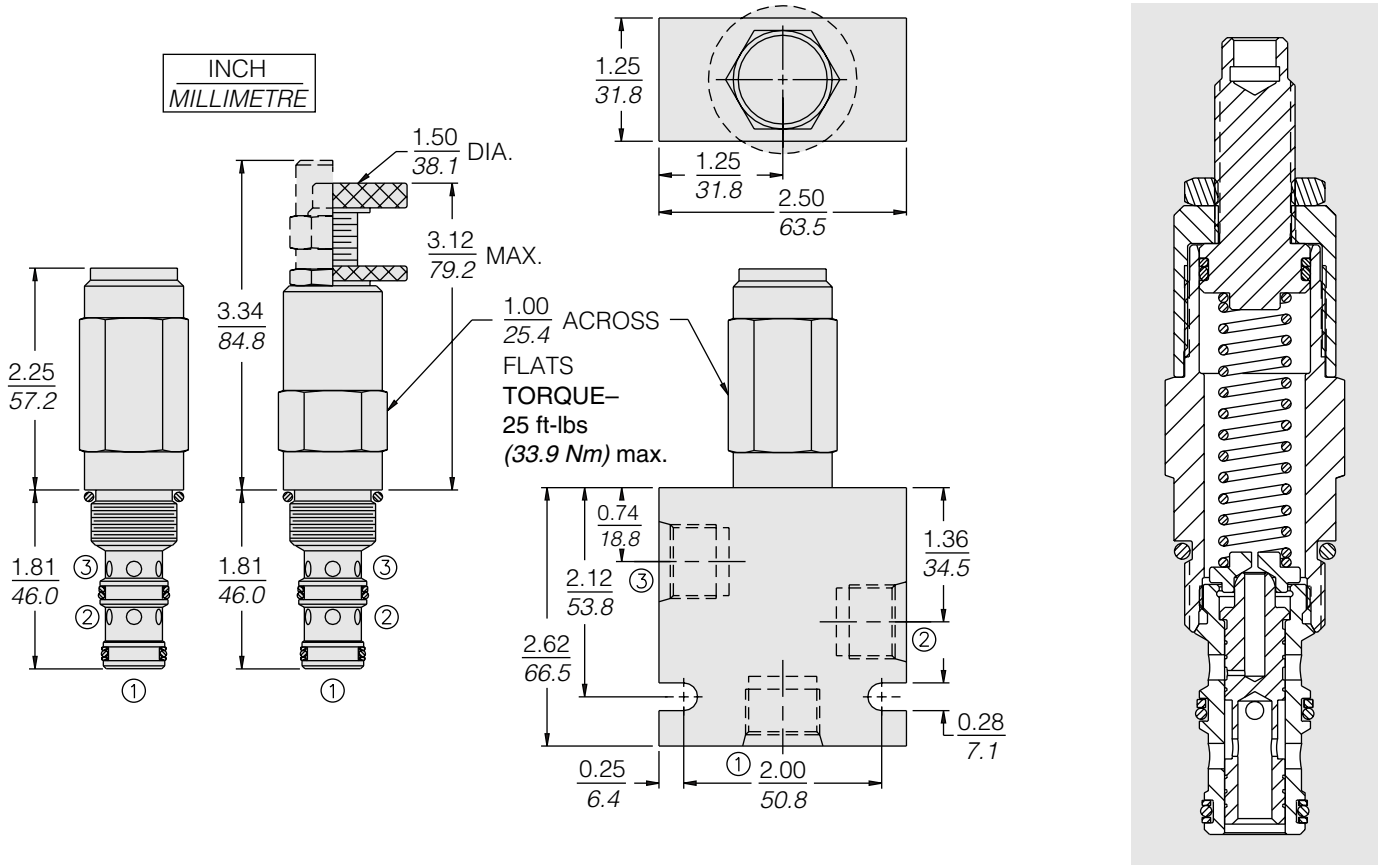

MATERIALS

Cartridge: Weight: 0.27 kg. (0.60 lbs.); Steel with hardened work surfaces. Zinc-plated exposed surfaces. Buna N O-rings and polyester elastomer back-ups standard. Anodized aluminum knobs and caps.

Standard Ported Body: Weight: 0.36 kg. (0.80 lbs.); Anodized high-strength 6061 T6 aluminum alloy, rated to 240 bar (3500 psi); see page 8.010.1. Ductile iron and steel bodies available; dimensions may differ; consult factory.

TO ORDER

PR10-32

- Adjustment Option**
 1/4 in. Hex Allen Head **A**
 1-1/2 in. Dia. Alum. Knob **B**
 Option A w/Cover Cap **C**
 Factory Preset Non-Adj. **F**
 Factory Preset Hidden **H**
 Adjust. (See page 6.003.1)
 Option C w/ Lockwire Holes **L**

- Porting**
 Cartridge Only **0**
 SAE 6 **6T**
 SAE 8 **8T**
 1/4 in. BSP* **2B**
 3/8 in. BSP* **3B**

*BSP Body; U.K. Mfr Only

- Seals**
 Buna N (Std.) **N**
 Fluorocarbon **V**

- Setting in bar[†]**
 (Blank) for Adjustable, or Specify, for example:
M25 25 bar
M100 100 bar
Setting in psi[†]
 (Blank) for Adjustable, or Specify, for example:
9.0 900 psi
21.0 2100 psi

- Spring Range**
4 5.5 to 27.6 bar (80 to 400 psi)
8 13.8 to 55.2 bar (200 to 800 psi)
15 20.7 to 103 bar (300 to 1500 psi)
21 27.6 to 145 bar (400 to 2100 psi)

[†]Adjustable valves will be preset to approx. 50% of spring max. potential.