

FD10-41 Flow Divider/Combiner, Cylinder Synch.

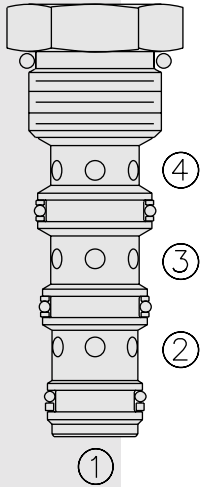

DESCRIPTION

A screw-in, cartridge-style, spool-type flow divider/combiner. Optional flow dividing/combining ratios are maintained regardless of system operating pressure conditions.

OPERATION

In the dividing mode, the **FD10-41** will divert input flow from port ③ to ports ② and ④, based on the ratio specified, regardless of operating pressure.

The cartridge will combine input flows from ports ② and ④.

The FD10-41 is designed to allow synchronizing flow to the opposite cylinder once a cylinder has “bottomed” in the combining mode.

FEATURES

- Hardened parts for long life.
- Quiet, modulated response.
- Industry common cavity.

RATINGS

Operating Pressure: 240 bar (3500 psi)

Flow: 45.4 lpm (12 gpm) input max.

Flow Options:

- Input Flow: 7.6 lpm (2 gpm); Ratio: 50:50; Model Code: 11
 - Input Flow: 15.1 lpm (4 gpm); Ratio: 50:50; Model Code: 22
 - Input Flow: 22.7 lpm (6 gpm); Ratio: 50:50; Model Code: 33
 - Input Flow: 30.3 lpm (8 gpm); Ratio: 50:50; Model Code: 44
 - Input Flow: 37.9 lpm (10 gpm); Ratio: 50:50; Model Code: 55
 - Input Flow: 45.4 lpm (12 gpm); Ratio: 50:50; Model Code: 66
- Other ratio options available; consult factory.

Standard Compensator Bias Spring: 2.07 bar (30 psid)

Flow Accuracy: 10% from 30–100% of rated flow

Temperature: -40 to 120°C

Filtration: See page 9.010.1

Fluids: Mineral-based or synthetics with lubricating properties at viscosities of 7.4 to 420 cSt (50 to 2000 ssu)

Installation: No restrictions; See page 9.020.1. Note: Standard 10 size 4-way bodies should not be used with this product. See page 8.010.1 for special flow divider bodies.

Cavity: VC10-4 (Variation “A”); See page 9.110.1

Cavity Tool: CT10-4XX; See page 8.600.1

Seal Kit: SK10-4X-MMT; See page 8.650.1

SYMBOLS

USAS/ISO:

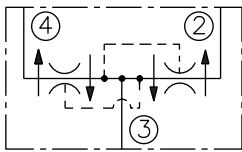

PERFORMANCE (Cartridge Only)

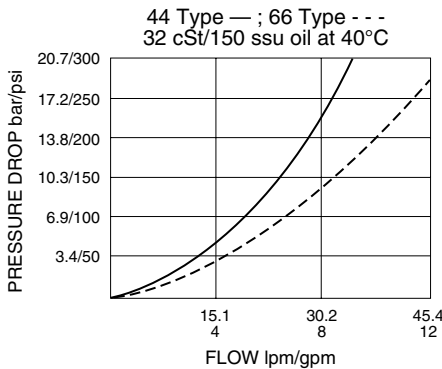

Note: This model will be superseded by the new FDxx-45 models, which incorporate the features of the FDxx-40, FDxx-41 and FDxx-42 series valves in one product. OEM's are encouraged to consider the newer, more robust and versatile FDxx-45 models for new applications:

- FD10-45; see page 5.632.1
- FD12-45; see page 5.634.1
- FD16-45; see page 5.636.1

DIMENSIONS

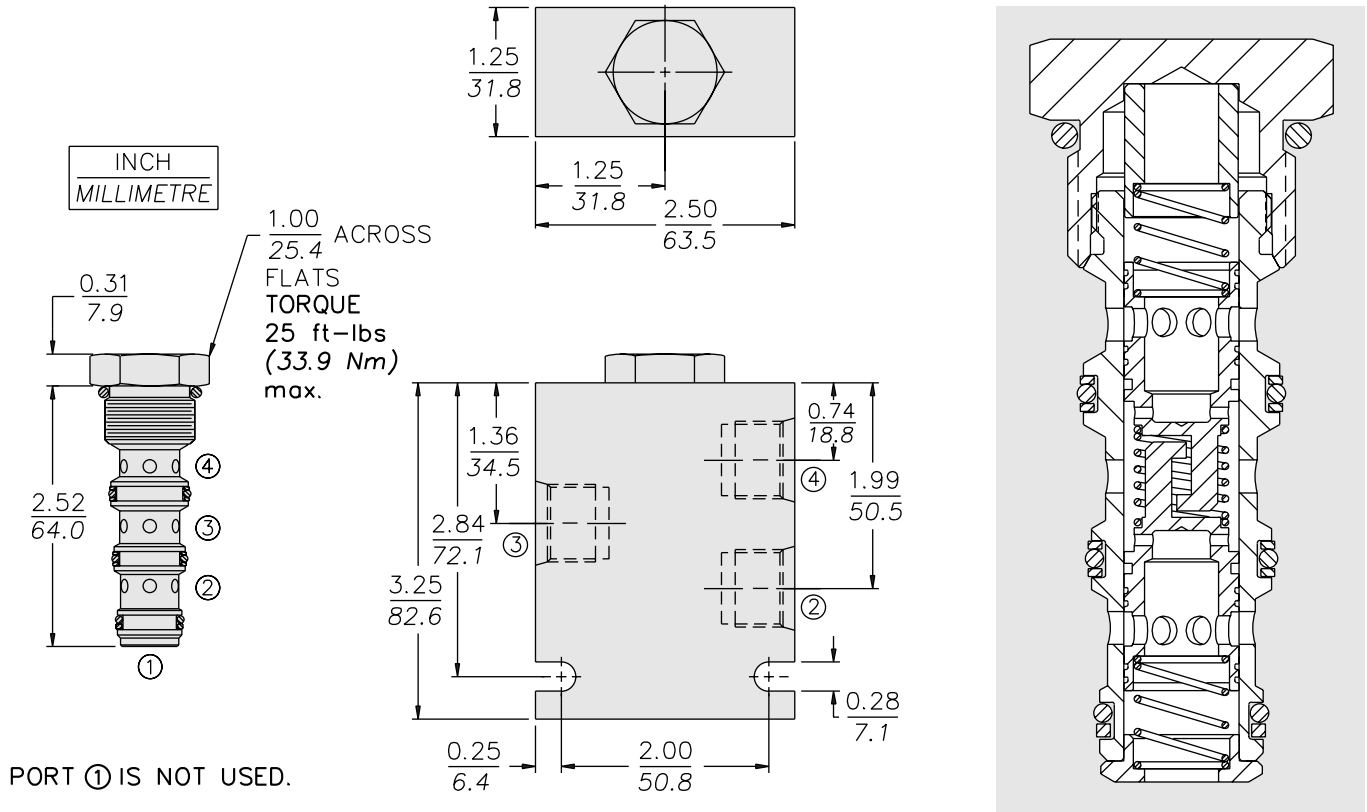

PORT ① IS NOT USED.

MATERIALS

Cartridge: Weight: 0.10 kg. (0.23 lbs.); Steel with hardened work surfaces. Zinc-plated exposed surfaces. Buna N O-rings and polyester elastomer back-ups standard.

Special Ported Body: Weight: 0.34 kg. (0.75 lbs.); Anodized high-strength 6061 T6 aluminum alloy, rated to 240 bar (3500 psi); See page 8.010.1. Ductile iron and steel bodies available; dimensions may differ; consult factory.

TO ORDER

FD10-41 -

Special Ported Bodies

- Cartridge Only **0**
- SAE 6 (All Ports) **6T**
- SAE 8 ③; **8D**
- SAE 6 ② & ④
- 1/4 in. BSP* (All Ports) **2B**
- 3/8 in. BSP* (All Ports) **3B**
- 1/2 in. BSP* ③;
- 3/8 in. BSP* ② & ④ **5B**

*BSP Body; U.K. Mfr. Only

Dividing/Combining Ratio

- 11** 50:50 rated @ 7.6 lpm (2 gpm) input
- 22** 50:50 rated @ 15.1 lpm (4 gpm) input
- 33** 50:50 rated @ 22.7 lpm (6 gpm) input
- 44** 50:50 rated @ 30.3 lpm (8 gpm) input
- 55** 50:50 rated @ 37.9 lpm (10 gpm) input
- 66** 50:50 rated @ 45.4 lpm (12 gpm) input

Seals

- N** Buna N (Std.)
- V** Fluorocarbon

NOTE: Standard 10-size 4-way bodies should not be used for flow dividers. See special flow divider bodies, page 8.010.1.

NOTE: Additional ratios and/or input flow sizings available for OEM applications. Consult factory.