

EC42-M40 Pressure Compensator

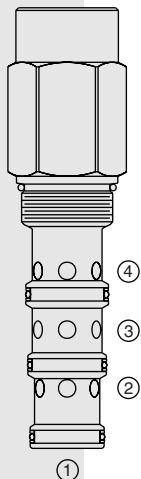

DESCRIPTION

A screw-in, cartridge-style pressure-compensating element intended for use with a remote fixed or variable orifice to yield a three-port (bypass-type), pressure-compensated, flow regulating hydraulic valve.

OPERATION

The **EC42-M40** maintains a constant flow rate from ③ regardless of load pressure changes in the circuit downstream of ③.

The cartridge maintains a constant differential pressure from circuit point "P" to port ③ (see symbol), thereby regulating the hydraulic flow rate between the two points in the circuit. The EC42-M40 is a priority type regulator, delivering pump flow first to ③, then bypassing excess to ②. All ports may be fully pressurized.

FEATURES

- Hardened parts for long life.
- Quiet, modulated response.
- Industry common cavity.

RATINGS

Operating Pressure: Inlet: 240 bar (3500 psi)

Maximum Inlet Flow: 302.8 lpm (80.0 gpm)

Maximum Regulated Flow: 151.1 lpm (40.0 gpm) with 5.5 bar (80 psi) compensating spring; 208.2 lpm (55.0 gpm) with 10.3 bar (150 psi) compensating spring

Maximum Bypass Flow: 170.3 lpm (45.0 gpm) with 5.5 bar (80 psi) compensating spring; 208.2 lpm (55.0 gpm) with 10.3 bar (150 psi) compensating spring

Flow Maintenance: see performance chart

Temperature: -40 to 120°C with Buna N seals

Filtration: See page 9.010.1

Fluids: Mineral-based or synthetics with lubricating properties at viscosities of 7.4 to 420 cSt (50 to 2000 ssu)

Installation: No restrictions; See page 9.020.1

Cavity: VC42-M4; See page 9.142.1

Cavity Tool: CT42-M4XX; See page 8.600.1

Seal Kit: SK42-4X-MMM; See page 8.650.1

SYMBOLS

USASI/ISO:

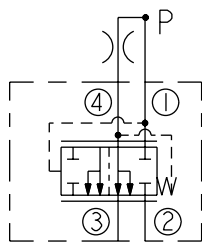

PERFORMANCE (Cartridge Only)

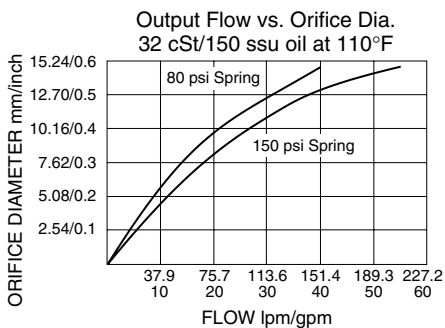

DIMENSIONS

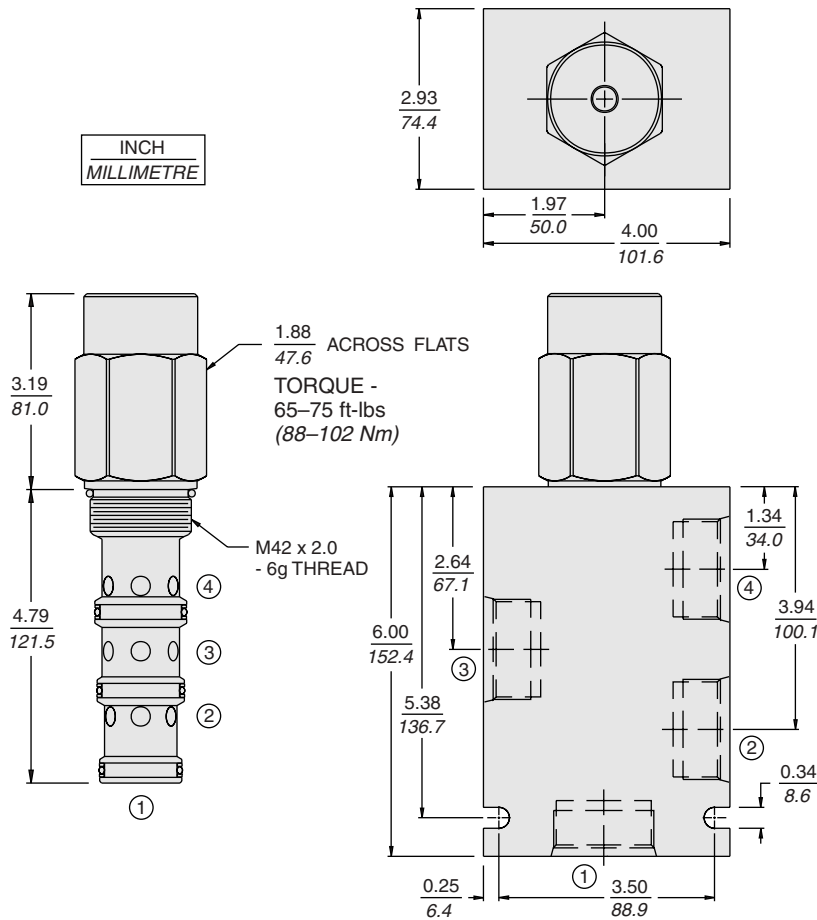

MATERIALS

Cartridge: Weight: 1.56 kg. (3.44 lbs.); Steel with hardened work surfaces. Zinc-plated exposed surfaces. Buna N O-rings and polyester elastomer back-ups standard.

Standard Ported Body: Weight: 0.34 kg. (0.75 lbs.); Anodized high-strength 6061 T6 aluminum alloy, rated to 240 bar (3500 psi); see page 8.042.1. Ductile iron and steel bodies available; dimensions may differ; consult factory.

TO ORDER

