

EC12-40 Pressure Compensator

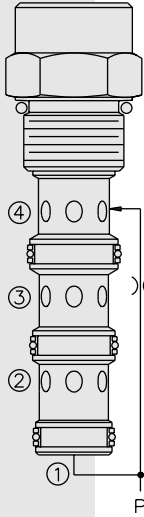

DESCRIPTION

A screw-in, cartridge-style pressure-compensating element, intended for use with a remote fixed or variable orifice to yield a three-port (bypass-type), pressure-compensated, flow regulating hydraulic valve.

OPERATION

The **EC12-40** maintains a constant flow rate from ③ regardless of load pressure changes in the circuit downstream of ③.

The cartridge maintains a constant differential pressure from circuit point P to port ③ (see USASI Symbol), thereby regulating the hydraulic flow rate between the two points in the circuit. The EC12-40 is a priority type regulator, delivering pump flow first to ③, then bypassing excess to ②. All ports may be fully pressurized.

FEATURES

- Hardened parts for long life.
- Quiet, modulated response.
- Cost effective cavity.

RATINGS

Operating Pressure: 240 bar (3500 psi)

Flow Rate: 80 lpm (21 gpm) max. regulated; 120 lpm (32 gpm) max. input; 68 lpm (18 gpm) bypass

Standard Compensator Bias Spring: 6.9 bar (100 psid) (See note on Ordering Table.)

Flow Maintenance: 7.57 to 75.7 lpm (2 to 20 gpm) settings $\pm 10\%$

Temperature: -40 to 120°C

Filtration: See page 9.010.1

Fluids: Mineral-based or synthetics with lubricating properties at viscosities of 7.4 to 420 cSt (50 to 2000 ssu)

Installation: No restrictions; See page 9.020.1

Cavity: VC12-4; See page 9.112.1

Cavity Tool: CT12-4XX; See page 8.600.1

Seal Kit: SK12-4X-MMM; See page 8.650.1

SYMBOLS

USASI/ISO:

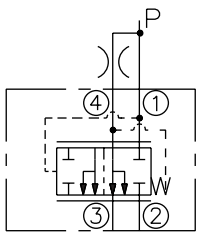

PERFORMANCE (Cartridge Only)

Output Flow vs. Orifice Dia.
with 100 psid Spring
32 cSt/150 ssu oil at 40°C

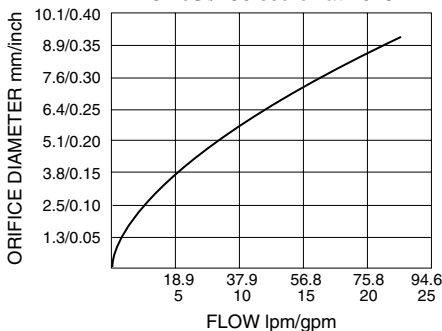

DIMENSIONS

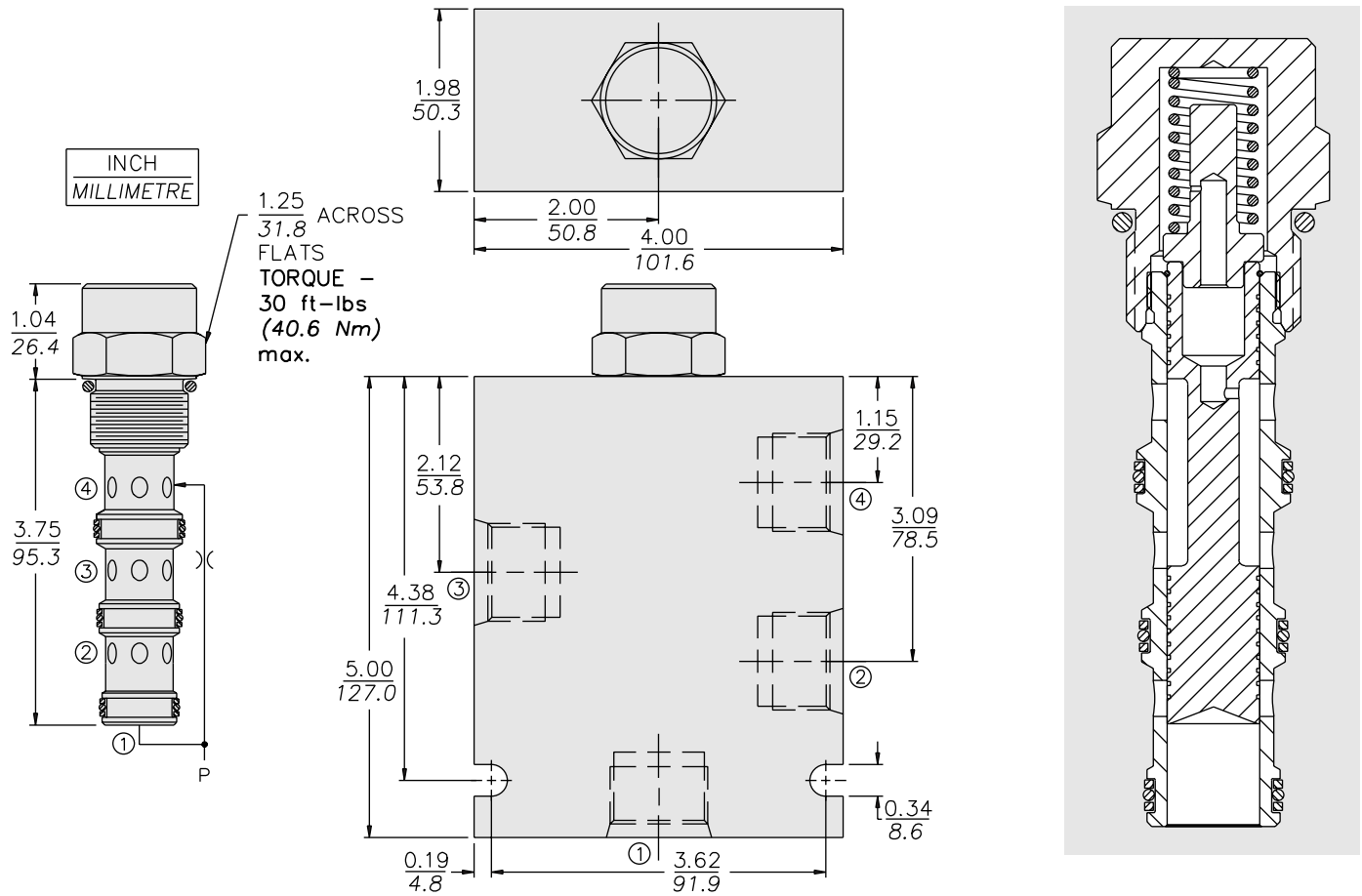

MATERIALS

Cartridge: Weight: 0.28 kg. (0.61 lbs.);
Steel with hardened work surfaces.
Zinc-plated exposed surfaces.
Buna N O-rings and polyester elastomer back-ups standard.

Standard Ported Body: Weight:
1.50 kg. (3.30 lbs.); Anodized high-strength 6061 T6 aluminum alloy, rated to 240 bar (3500 psi); see page 8.012.1. Ductile iron and steel bodies available; dimensions may differ; consult factory.

TO ORDER

EC12-40 - - -

Porting		Compensator Spring
Cartridge Only	0	100 6.9 bar (100 psid) standard
SAE 10	10T	160 11.0 bar (160 psid)
SAE 12	12T	
		Seals
		N Buna N (Std.)
		V Fluorocarbon