

EC12-34 Pressure Compensator, Load Holding

Patent Pending

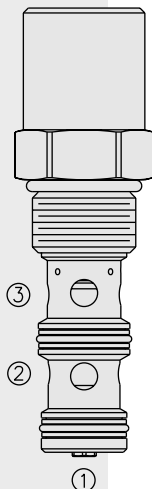

DESCRIPTION

A screw-in, cartridge-style, load sense, flow-on-demand pressure-compensator with built-in damping and load-holding features for use in gravity-lowering circuits.

OPERATION

The EC12-34 is designed to be used in combination with a flow control valve for lowering and holding a load. With inlet flow at port ②, port ③ will deliver required flow regardless of load pressure at ②. Port ① of the compensator must be connected to the outlet of a flow control valve that is connected to the tank.

FEATURES

- Hardened parts for long life.
- Hardened seat for low-leakage load-holding capability.
- Quiet, modulated response.
- Industry common cavity.

RATINGS

Operating Pressure: Inlet: 241 bar (3500 psi)

Maximum Regulated Flow: 83 lpm (22 gpm) with 200 psi compensating spring

Flow Maintenance: See performance chart

Leakage: ① to ② at 241 bar (3500 psi): 5 drops per minute when external metering orifice is closed; 160 ml (10 cu. in.) per minute when external metering orifice is open.

Temperature: -40 to 120°C with Buna N seals

Filtration: See page 9.010.1

Fluids: Mineral-based or synthetics with lubricating properties at viscosities of 7.4 to 420 cSt (50 to 2000 ssu)

Installation: No restrictions; See page 9.020.1

Cavity: VC12-3; See page 9.112.1

Cavity Tool: CT12-3XX; See page 8.600.1

Seal Kit: SK12-3X-MM; See page 8.650.1

SYMBOL

USASI/ISO:

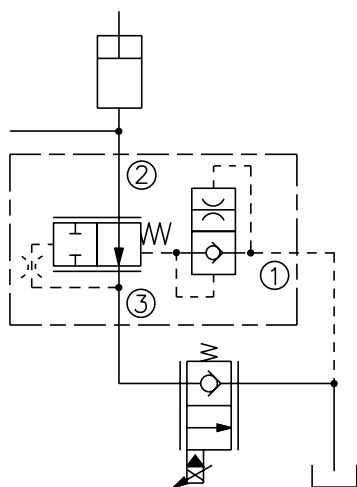

PERFORMANCE (Cartridge Only)

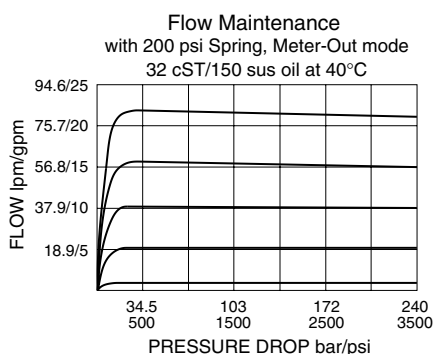

DIMENSIONS

Patent Pending

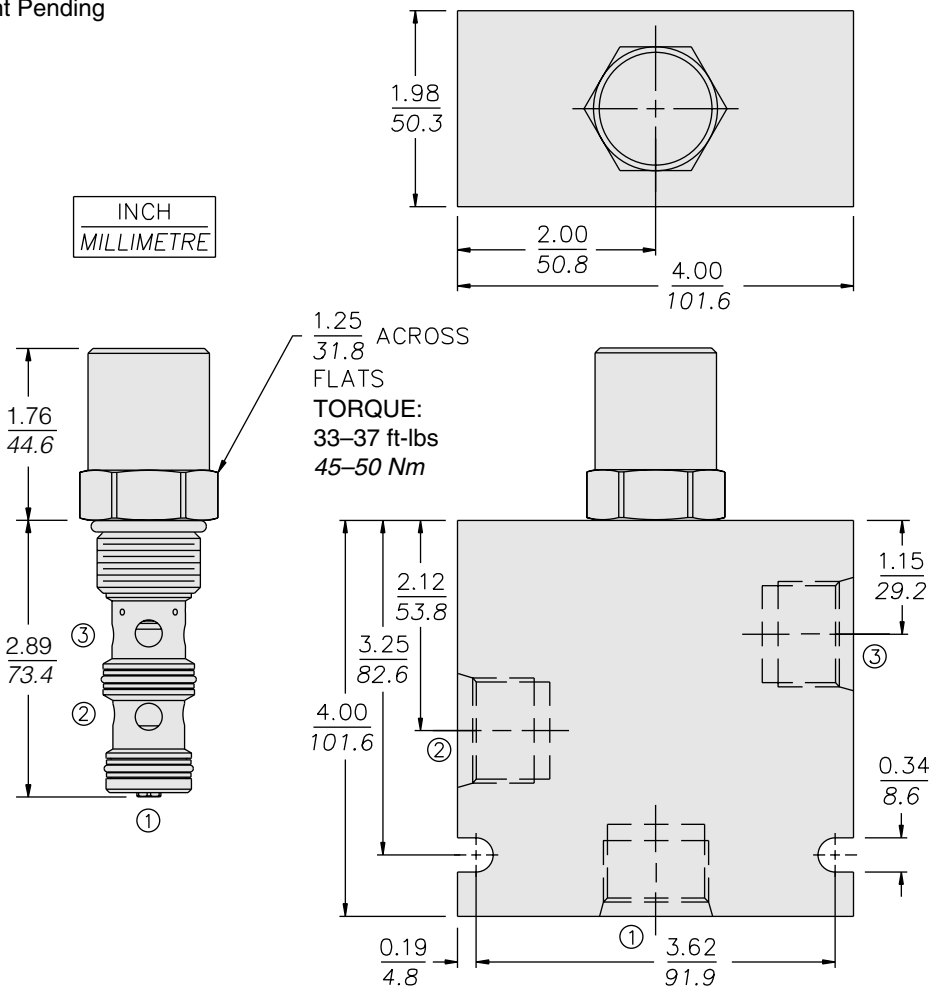

MATERIALS

Cartridge: Weight: 0.43 kg. (0.95 lbs.); Steel with hardened work surfaces. Zinc-plated exposed surfaces. Buna N O-rings and polyester elastomer back-ups standard.

Standard Ported Body: Weight: 1.13 kg. (2.5 lbs.); Anodized high-strength 6061 T6 aluminum alloy, rated to 240 bar (3500 psi); see page 8.012.1. Steel and Ductile iron bodies available, dimensions may differ; consult factory.

TO ORDER

EC12-34 - - - 200

Porting
Cartridge Only **0**
SAE 8 **8T**
SAE 10 **10T**
SAE 12 **12T**
1/2 in. BSP* **4B**
3/4 in. BSP* **6B**

*BSP Body;
U.K. Mfr. Only

Compensator Spring
200 13.8 bar (200 psid)

Seals
N Buna N (Std.)
V Fluorocarbon