

EC10-32 Pressure Compensator

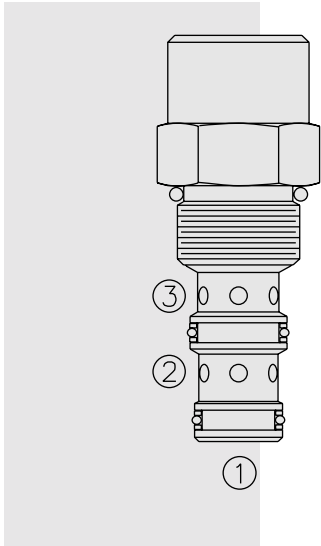

DESCRIPTION

A screw-in, cartridge-style, load sense, flow-on-demand pressure-compensator.

OPERATION

With inlet flow at ②, the **EC10-32** will deliver required flow at ③, in response to load differential pressure sensed at ①.

FEATURES

- Hardened parts for long life.
- Quiet, modulated response.
- Industry common cavity.

RATINGS

Operating Pressure: Inlet: 207 bar (3000 psi)

Maximum Regulated Flow: 38.1 lpm (10.0 gpm) with 150 psi compensating spring;
28.0 lpm (7.5 gpm) with 80 psi compensating spring.

Flow Maintenance: See performance chart

Temperature: -40 to 120°C with Buna N seals

Filtration: See page 9.010.1

Fluids: Mineral-based or synthetics with lubricating properties at viscosities of 7.4 to 420 cSt (50 to 2000 ssu)

Installation: No restrictions; See page 9.020.1

Cavity: VC10-3; See page 9.110.1

Cavity Tool: CT10-3XX; See page 8.600.1

Seal Kit: SK10-3X-TB; See page 8.650.1

SYMBOLS

USASI/ISO:

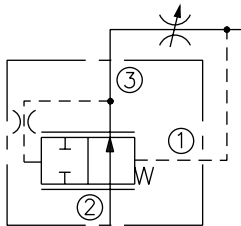

PERFORMANCE (Cartridge Only)

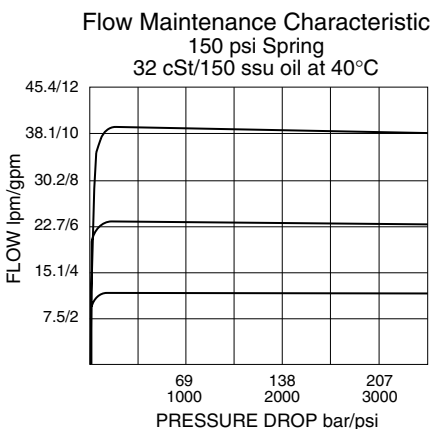

DIMENSIONS

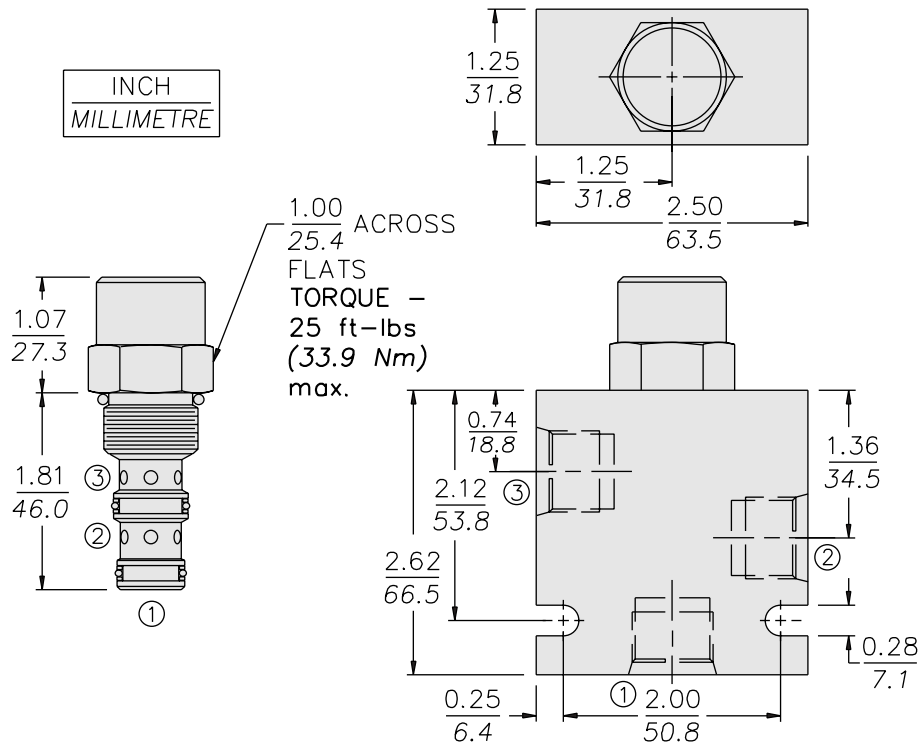

MATERIALS

Cartridge: Weight: 0.11 kg. (0.25 lbs.); Steel with hardened work surfaces. Zinc-plated exposed surfaces. Buna N O-rings and polyester elastomer back-ups standard.

Standard Ported Body: Weight: 0.36 kg. (0.80 lbs.); Anodized high-strength 6061 T6 aluminum alloy, rated to 240 bar (3500 psi); see page 8.010.1. Ductile iron and steel bodies available; dimensions may differ; consult factory.

TO ORDER

EC10-32 -

Porting
Cartridge Only **0**
SAE 6 **6T**
SAE 8 **8T**
1/4 in. BSP* **2B**
3/8 in. BSP* **3B**

*BSP Body;
U.K. Mfr. Only

Compensator Spring

80 5.5 bar (80 psid)
150 10.3 bar (150 psid)

Seals

N Buna N (Std.)
V Fluorocarbon