

FR10-30A Regulator, Pressure-Compensated

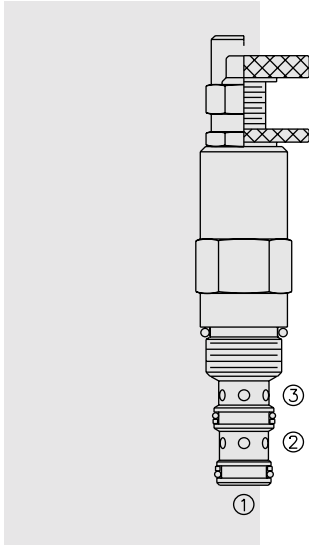

DESCRIPTION

A screw-in, cartridge-style, fixed orifice, pressure-compensated, bypass-type hydraulic flow regulating valve, with limited range adjustment from a pre-determined nominal setting.

OPERATION

The **FR10-30A** maintains a constant flow rate from ③ regardless of load pressure changes in the system downstream of ③, or in the bypass leg at ②.

The valve will pressure-compensate once a minimum pressure drop (determined by spring adjustment setting) is achieved from ① to ③. This value will range from approximately 4.8 to 13.8 bar (70 to 200 psid).

The cartridge may be adjusted to $\pm 25\%$ of nominal setting. At nominal setting, pressure drop is approximately 9 bar (130 psid).

Flow out of priority port ③ may vary based on input flow amount, particularly with lower temperatures and increased fluid viscosities. Settings may need to be established through correlation study. Consult factory.

FEATURES

- Bypass port ② may be fully pressurized.
- Hardened steel parts for long life.
- Quiet, modulated response.
- Industry common cavity.

SYMBOLS

USASI:

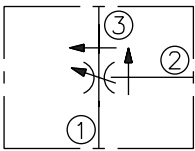

ISO:

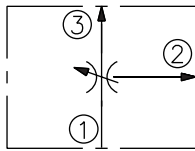

PERFORMANCE (Cartridge Only)

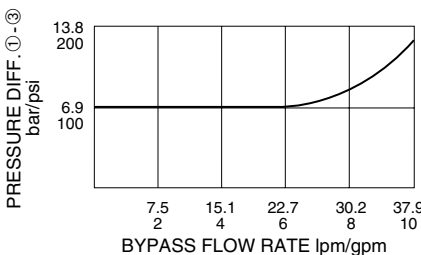
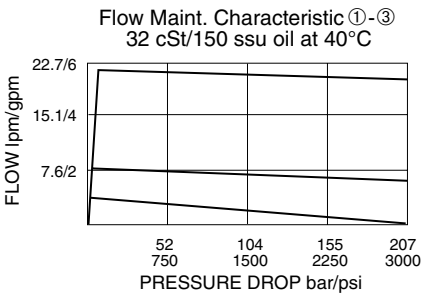

RATINGS

Operating Pressure: 207 bar (3000 psi)

Customer-Specified Standard Flow Setting:

Low Range: 1.9 to 9.5 lpm (0.5 to 2.5 gpm); Specify in 1.9 lpm (0.5 gpm) increments

High Range: 11.4 to 22.7 lpm (3.0 to 6.0 gpm); Specify in 3.8 lpm (1 gpm) increments

See ordering table on facing page.

Pressure at ① begins to rise higher than compensating pressure differential when bypass flow exceeds 23 lpm (6 gpm).

Temperature: -40 to 120°C

Filtration: See page 9.010.1

Fluids: Mineral-based or synthetics with lubricating properties at viscosities of 7.4 to 420 cSt (50 to 2000 ssu)

Installation: No restrictions; See page 9.020.1

Cavity: VC10-3; See page 9.110.1

Cavity Tool: CT10-3XX; See page 8.600.1

Seal Kit: SK10-3X-TB; See page 8.650.1

NOTE: For certain applications with substantial dynamic load changes, particularly in cases where there is high differential pressure, we recommend the use of the FR10-33 (page 5.372.1) or the FR10-39 (page 5.382.1) in place of this valve.

FR10-30A

DIMENSIONS

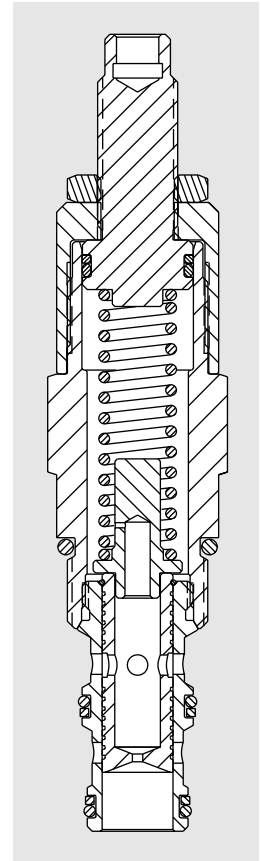
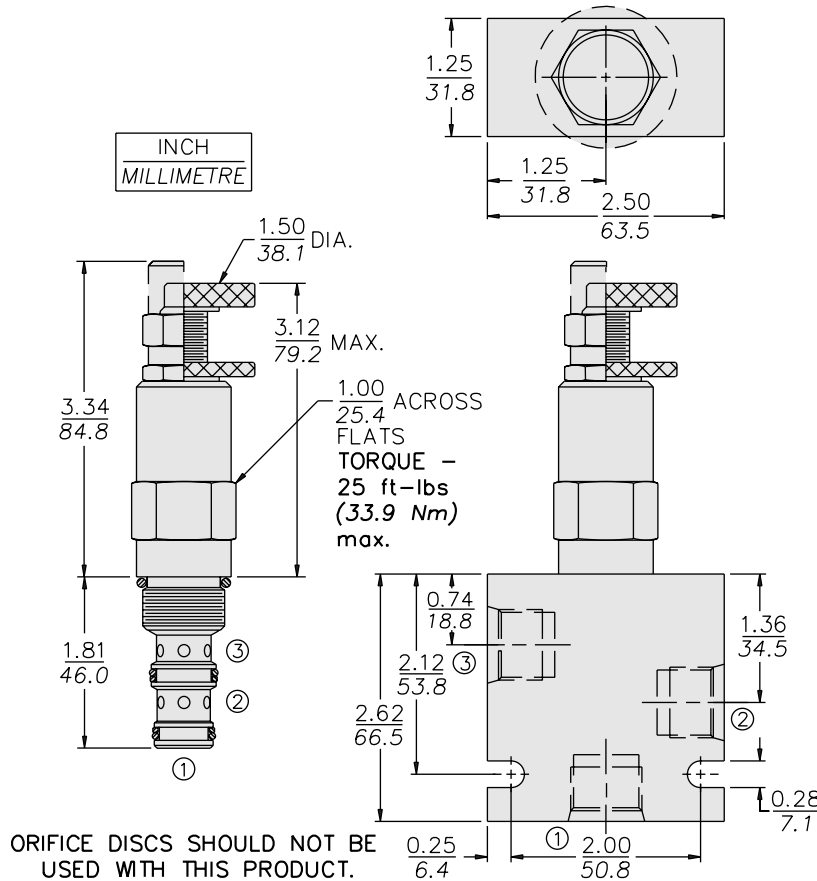

MATERIALS

Cartridge: Weight: 0.27 kg. (0.60 lbs.)
 Steel with hardened work surfaces.
 Zinc-plated exposed surfaces.
 Buna N O-rings and polyester elastomer back-ups standard.
 Optional aluminum knob.

Standard Ported Body: Weight: 0.36 kg. (0.80 lbs.); Anodized high-strength 6061 T6 aluminum alloy, rated to 240 bar (3500 psi); see page 8.010.1. Ductile iron and steel bodies available; dimensions may differ; consult factory.

TO ORDER

FR10-30		-	-	- /	-
Adjustment Option					
1/4 in. Hex Allen Head	A				
1-1/2 in. Dia. Alum. Knob	B				
Option A w/ Cover Cap	C				
Option B w/ Lock Nut	D				
Factory Preset					
Hidden Adjustment	H				
Porting					
Cartridge Only	0				
SAE 6	6T				
SAE 8	8T				
1/4 in. BSP*	2B				
3/8 in. BSP*	3B				
*BSP Body; U.K. Mfr. Only					
Seals					
Buna N (Std.)	N				
Fluorocarbon	V				
					Standard Settings[†]
				0.5	1.42 to 2.37 lpm (0.37 to 0.63 gpm)
				1.0	2.84 to 4.73 lpm (0.75 to 1.25 gpm)
				2.0	5.68 to 9.46 lpm (1.5 to 2.5 gpm)
				2.5	7.08 to 11.81 lpm (1.87 to 3.12 gpm)
				3.0	8.52 to 14.19 lpm (2.25 to 3.75 gpm)
				4.0	11.35 to 18.93 lpm (3.0 to 5.0 gpm)
				5.0	14.19 to 23.66 lpm (3.75 to 6.25 gpm)
				6.0	17.03 to 28.93 lpm (4.5 to 7.5 gpm)

Note: Compensator spring values may be varied for OEM application, to provide changed differential pressure/output flow relationships. Consult factory.

[†]At mean, adjustment = ±25%; Additional mean settings available on OEM request; consult factory.