

# FLOW CONTROLS

## NV08-21 Needle Valve with Positive Shut-Off

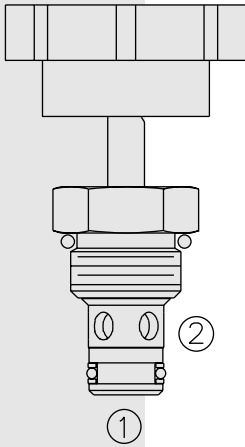

### DESCRIPTION

A screw-in, cartridge-style, variable orifice, hydraulic flow restrictor valve. It is intended for applications requiring fine adjustment over multiple turns.

### OPERATION

The **NV08-21** increases its orifice value from fully closed to fully open with adjustment rotation in the counterclockwise direction. Effective adjustment is linear to eight turns.

Note: This is intended as a low-effort adjustment suitable for operation through linkage. It may be unsuitable in environments where vibration is present.

### FEATURES

- Adjustment cannot be backed out of the valve.
- Hardened parts for long life.
- Industry common cavity.
- Fine/low effort adjustment.
- Positive shut-off.
- Linear adjustment.

### RATINGS

**Operating Pressure:** 240 bar (3500 psi)

**Flow:** See Performance Chart

**Internal Leakage:** 0.25 cc/minute (5 drops/minute) max. at shut-off

**Adjustment Torque Required:** 0.34 Nm (3 inch-pounds) at 7 bar (100 psi); 0.68 Nm (6 inch-pounds) at 207 bar (3000 psi)

**Temperature:** -40 to 120°C

**Filtration:** See page 9.010.1

**Fluids:** Mineral-based or synthetics with lubricating properties at viscosities of 7.4 to 420 cSt (50 to 2000 ssu)

**Installation:** No restrictions; See page 9.020.1

**Cavity:** VC08-2; See page 9.108.1

**Cavity Tool:** CT08-2XX; See page 8.600.1

**Seal Kit:** SK08-2X-M; See page 8.650.1

### SYMBOLS

USASI/ISO:

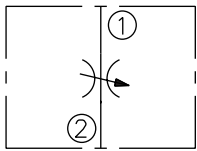

### PERFORMANCE (Cartridge Only)

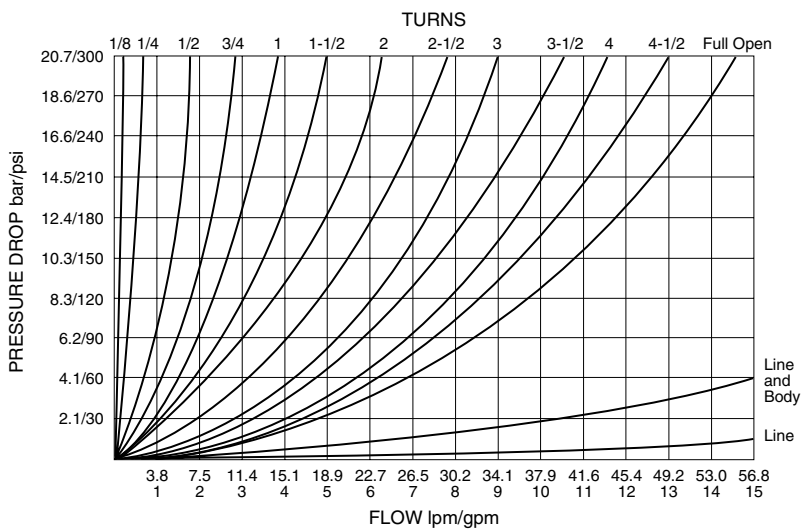

# NV08-21

## DIMENSIONS

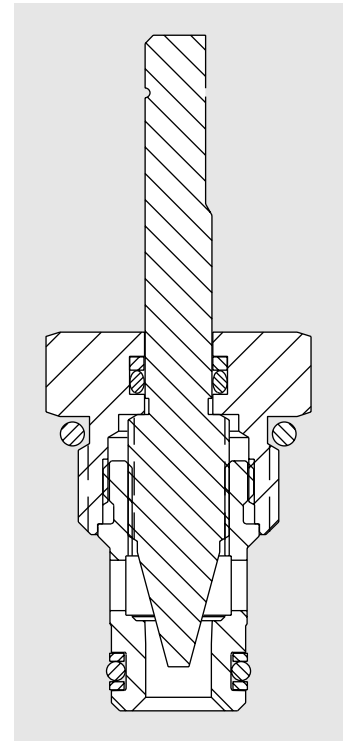
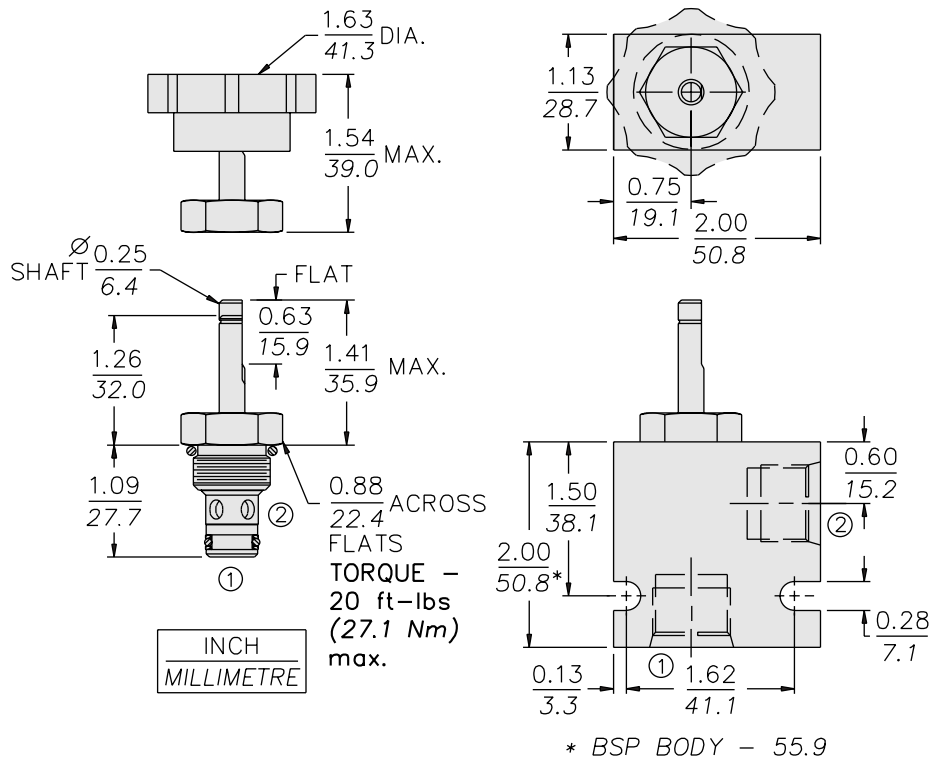

## MATERIALS

**Cartridge:** Weight: 0.14 kg. (0.30 lbs.); Steel with hardened work surfaces. Zinc-plated exposed surfaces. Buna N O-rings and polyester elastomer back-ups standard. Plastic knob with metal insert.

**Standard Ported Body:** Weight: 0.16 kg. (0.35 lbs.); Anodized high-strength 6061 T6 aluminum alloy, rated to 240 bar (3500 psi); see page 8.008.1. Ductile iron and steel bodies available; dimensions may differ; consult factory.

## TO ORDER

<b>NV08-21</b>		-	-
<b>Adjustment Option</b>	T		<b>Seals</b>
Extended Shaft Only	E		N Buna N (Std.)
Plastic Knob			V Fluorocarbon
			<b>Porting</b>
			0 Cartridge Only
			4T SAE 4
			6T SAE 6
			8T SAE 8
			2B 1/4 in. BSP*
			3B 3/8 in. BSP*
			4B 1/2 in. BSP*
			*BSP Body; U.K. Mfr. Only