

Proportional Valve Controller—DIN Rail Mount—

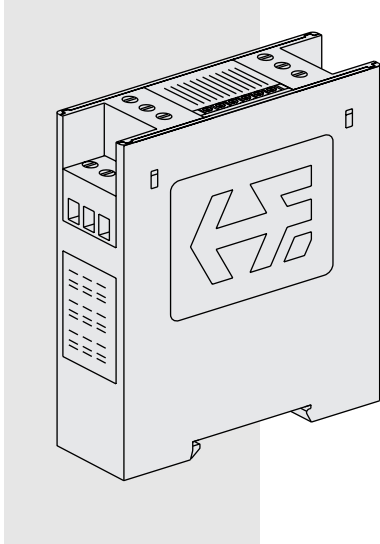

DESCRIPTION *PWM (Pulse Train) Input*

A DIN rail-mount style control amplifier for controlling HydraForce proportional valves. Remote mounting in a protected enclosure is required.

OPERATION

This control module uses closed-loop current control with superimposed dither to supply a proportional valve solenoid with a proportional control signal. The input signal to this controller can be from a PWM (pulse train) source.

FEATURES

- Adjustments and connections clearly labeled.
- LED indication of output power level, input level and power on/off.
- One unit covers supply voltages from 9 to 32 VDC.
- No internal fuses; circuit limits current electronically.
- Short circuit proof and reverse polarity protected.
- Can be disconnected from coil when powered.
- Maximum current adjustment does not affect minimum current setting.
- Current sensing circuit maintains output current regardless of changes in input voltage or coil resistance.
- Independent ramp adjustments.
- Filter eliminates electrical noise.
- Dither frequency and amplitude are adjustable for maximum valve performance.

GENERAL SPECIFICATIONS

Weight: 25 g (0.88 oz.)

Connections: Screw terminals for 16–30 AWG wire

RATINGS

Supply Voltage: 9–32 VDC

Coil rating must be matched with supply voltage: $R_{COIL} \leq (V_{SUPPLY} - 1.5 \text{ V}) / I\text{-Max.}$

Control Input Signal: 250 to 5000 Hz PWM (pulse train); 5% to 95% duty cycle; Low < 1.5 volts; High > 3.5 volts; 50 volts maximum

Input Resistance: 9.7K Ohms

Output Current: up to 2000 mA (see ordering info.)

Minimum Current Range: 0–500 mA (adjustable)

Maximum Current Range: 600–2000 mA (adjustable)

Ramp Up and/or Down: 0.01–5.0 seconds (independently adjustable)

Dither Frequency: 70–350 Hz ($\pm 10\%$)

Dither Amplitude: 0–10% of maximum current (adjustable)

Operating Conditions: -20° to 85°C ; 0 to 85% relative humidity

SCHEMATIC

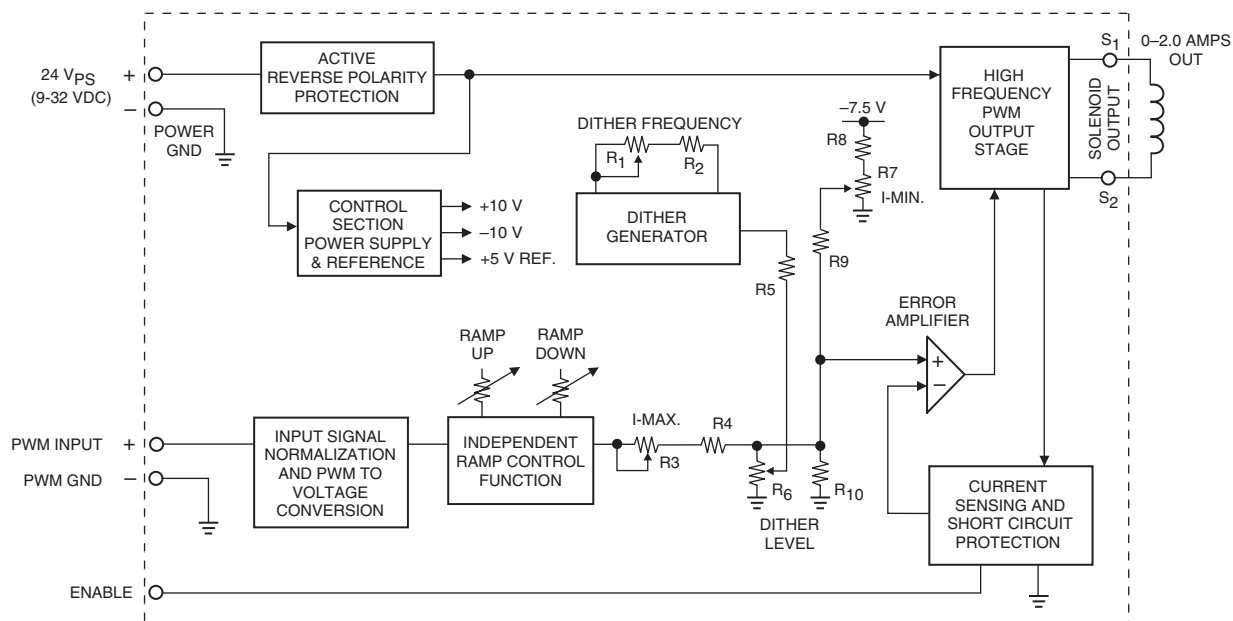

PWM (Pulse Train) Input

DIMENSIONS

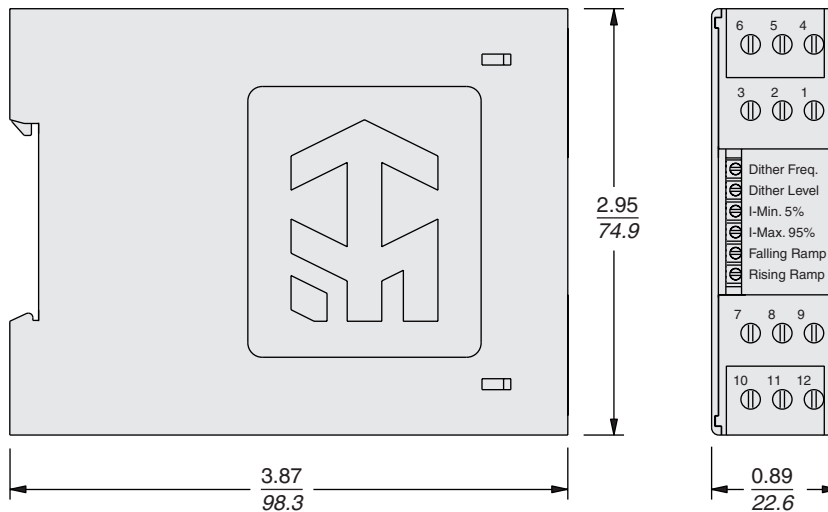

Screw Terminal Connections for 16–30 AWG wire

1. PWM In
2. Not Used
3. PWM Ground
4. (+) Power
5. Not Used
6. (-) Power
7. Enable
8. Not Used
9. Enable Ground
10. (+) Solenoid
11. Not Used
12. (-) Solenoid

INCH
MILLIMETRE

Note: When Enable is left open, the unit is enabled. When Enable is connected to Enable Ground, the unit will be disabled.

CONNECTIONS

For Complete Set-Up Instructions, see page 3.560.1

Basic Setup: Turn ramp screws fully counterclockwise to eliminate ramping. Use I-Min. screw to set minimum speed with minimum control input. Use I-Max. screw to set maximum speed with 100% of control input.

PWM (Pulse Train) Control

Supplied by User	Screw Terminal
PWM Input ———○ 1	PWM In
○ 2	Not Used
Ground ———○ 3	PWM Ground
(+) Power ———○ 4	(+) Power
○ 5	Not Used
(-) Power ———○ 6	(-) Power
Enable ———○ 7	Enable
○ 8	Not Used
Ground ———○ 9	Enable Ground
(+) Coil ———○ 10	(+) Solenoid
○ 11	Not Used
(-) Coil ———○ 12	(-) Solenoid

TO ORDER

Part Number	Output	I-Min. Setting	I-Max. Setting
4000140	2000 mA Max.	0 to 500 mA	600 to 2000 mA