

## Proportional Valve Controller—DIN Rail Mount—

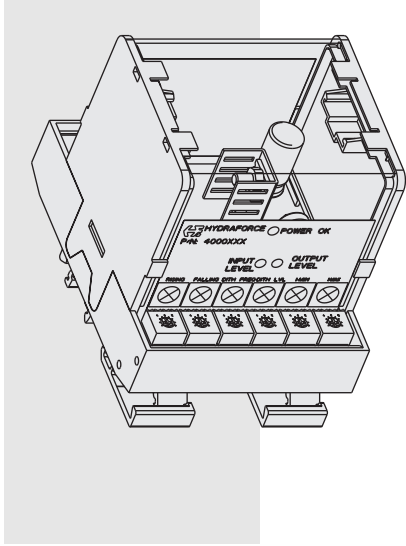

### DESCRIPTION *0–10 VDC Input*

A DIN rail-mount style control amplifier for controlling HydraForce proportional valves. Remote mounting in a protected enclosure is required.

### OPERATION

This control module uses closed-loop current control with superimposed dither to supply a proportional valve solenoid with a proportional control signal. The input signal to this controller can be from a 0–10 VDC source.

### FEATURES

- Adjustments and connections clearly labeled.
- LED indication of output power level, input level and power on/off.
- One unit covers supply voltages from 9 to 32 VDC.
- No internal fuses; circuit limits current electronically.
- Short circuit proof and reverse polarity protected.
- Can be disconnected from coil when powered.
- Maximum current adjustment does not affect minimum current setting.
- Independent ramp adjustments.
- Filter eliminates electrical noise.
- Dither frequency and amplitude are adjustable for maximum valve performance.

### RATINGS

**Supply Voltage:** 9–32 VDC

Coil rating must be matched with supply voltage:  $R_{COIL} \leq (V_{SUPPLY} - 1.5 V) / I_{MAX}$ .

**Control Input Signal:** 0–10 VDC

**Input Resistance:** 250K Ohms

**Output Current:** up to 2000 mA (see ordering info.)

**Minimum Current Range:** 0–500 mA (adjustable)

**Maximum Current Range:** 600–2000 mA (adjustable)

**Ramp Up and/or Down:** 0.01–5.0 seconds (independently adjustable)

**Dither Frequency:** 70–350 Hz ( $\pm 10\%$ )

**Dither Amplitude:** 0–10% of maximum current (adjustable)

**Operating Conditions:**  $-20^{\circ}$  to  $85^{\circ}\text{C}$ ; 0 to 85% relative humidity

### GENERAL SPECIFICATIONS

**Weight:** 25 g (0.88 oz.)

**Connections:** Screw terminals for 16–30 AWG wire

**CSA Listing:**  
CSA C22.2 No. 14-M91

### SCHEMATIC

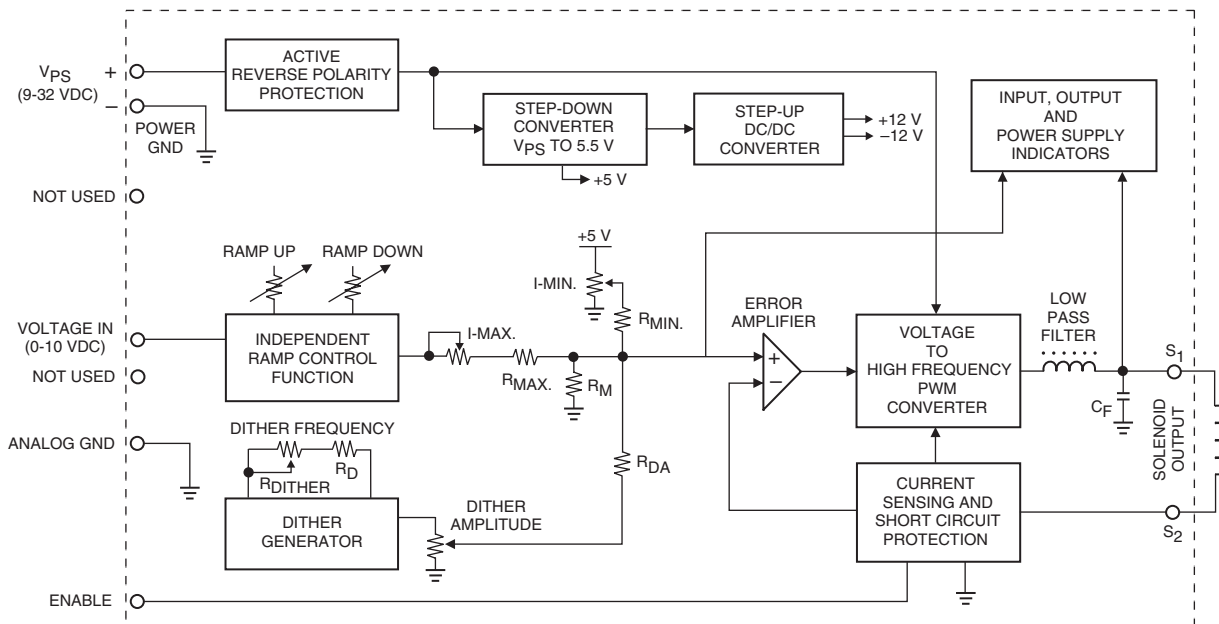

# 0-10 VDC Input

## DIMENSIONS

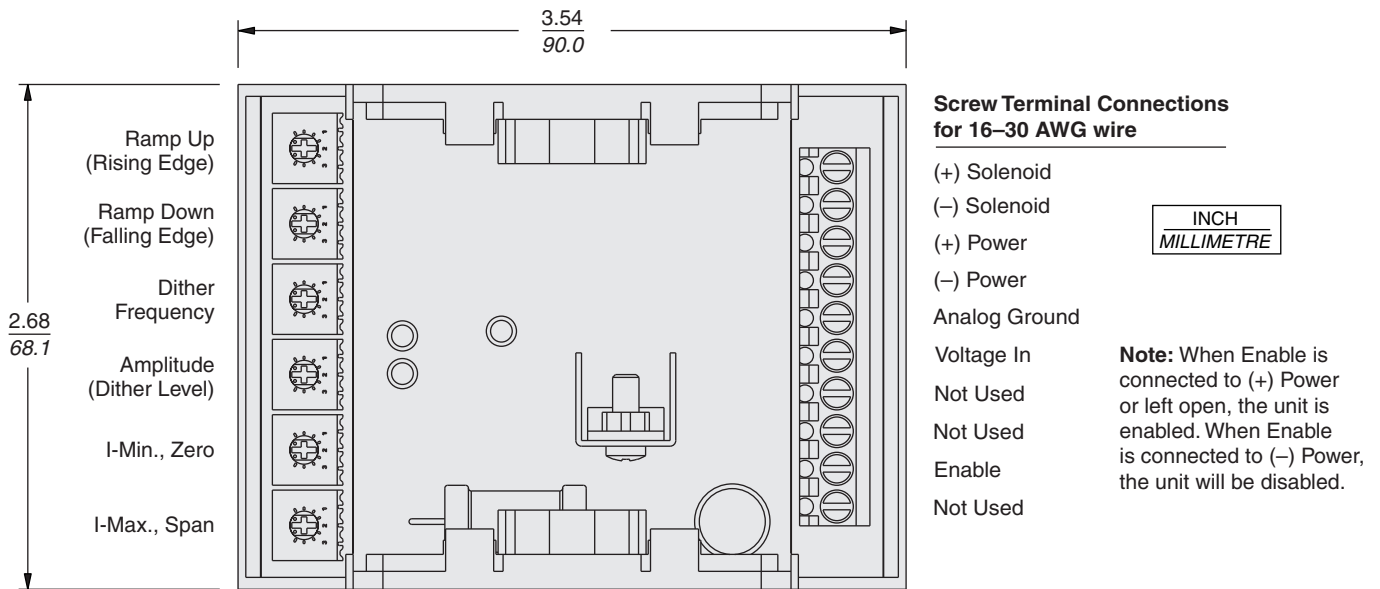

## CONNECTIONS

For Complete Set-Up Instructions, see page 3.560.1

**Basic Setup:** Controller is shipped with ramp trim pots fully counterclockwise to eliminate ramping. Use I-Min. screw to set minimum speed with minimum control input. Use I-Max. screw to set maximum speed with 100% of control input.

### 0 to 10 VDC Control

Supplied by User	Screw Terminal
(+) Coil	(+) Solenoid
(-) Coil	(-) Solenoid
(+) Power	(+) Power
(-) Power	(-) Power
(-) 0-10V	Analog Gnd.
(+) 0-10V	Voltage In
Not Used	Current In
	Not Used
Enable	Enable
Not Used	+5V Ref.

## TO ORDER

Part Number	Output	I-Min. Setting	I-Max. Setting
4000137	2000 mA Max.	0 to 500 mA	600 to 2000 mA