

Proportional Valve Controller—DIN Rail Mount—

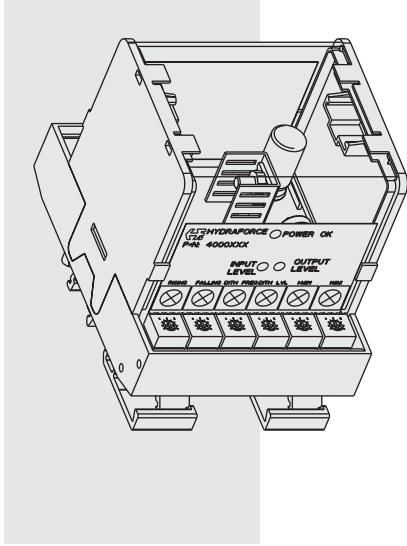

DESCRIPTION *0–5 VDC, 10K Pot or 0–20 mA Input*

A DIN rail-mount style control amplifier for controlling HydraForce proportional valves.

OPERATION

This control module uses closed-loop current control with superimposed dither to supply a proportional valve solenoid with a proportional control signal. The input signal to this controller can be from a 10K potentiometer, 0–5 VDC, 0–20 mA, or from other pre-set levels.

FEATURES

- Adjustments and connections clearly labeled.
- LED indication of output power level, input level and power on/off.
- One unit covers supply voltages from 9 to 32 VDC.
- No internal fuses; circuit limits current electronically.
- Short circuit proof and reverse polarity protected.
- Can be disconnected from coil when powered.
- Maximum current adjustment does not affect minimum current setting.
- Independent ramp adjustments and internal supply for potentiometer.
- Filter eliminates electrical noise.
- Dither frequency and amplitude are adjustable for maximum valve performance.

RATINGS

Supply Voltage: 9–32 VDC

Coil rating must be matched with supply voltage: $R_{COIL} \leq (V_{SUPPLY} - 1.5 V) / I_{MAX}$.

Control Input Signal Options: 10K external potentiometer (accepts 5K to 50K pots), or 0–5 VDC signal, or 0–20 mA current signal (see connection diagrams)

Input Resistance: Voltage: 250K Ohms; Current: 33 Ohms

Output Current: up to 2000 mA (see ordering info.)

Minimum Current Range: 0–500 mA (adjustable; see ordering info.)

Maximum Current Range: 600–2000 mA (adjustable; see ordering info.)

Ramp Up and/or Down: 0.01–5.0 seconds (independently adjustable)

Dither Frequency: 70–350 Hz (adjustable)

Dither Amplitude: 0–10% of maximum current (adjustable)

Operating Conditions: –20° to 85°C; 0 to 85% relative humidity

GENERAL SPECIFICATIONS

Weight: 25 g (0.88 oz.)

Connections: Screw terminals for 16–30 AWG wire

CSA Listing:
CSA C22.2 No. 14-M91

SCHEMATIC

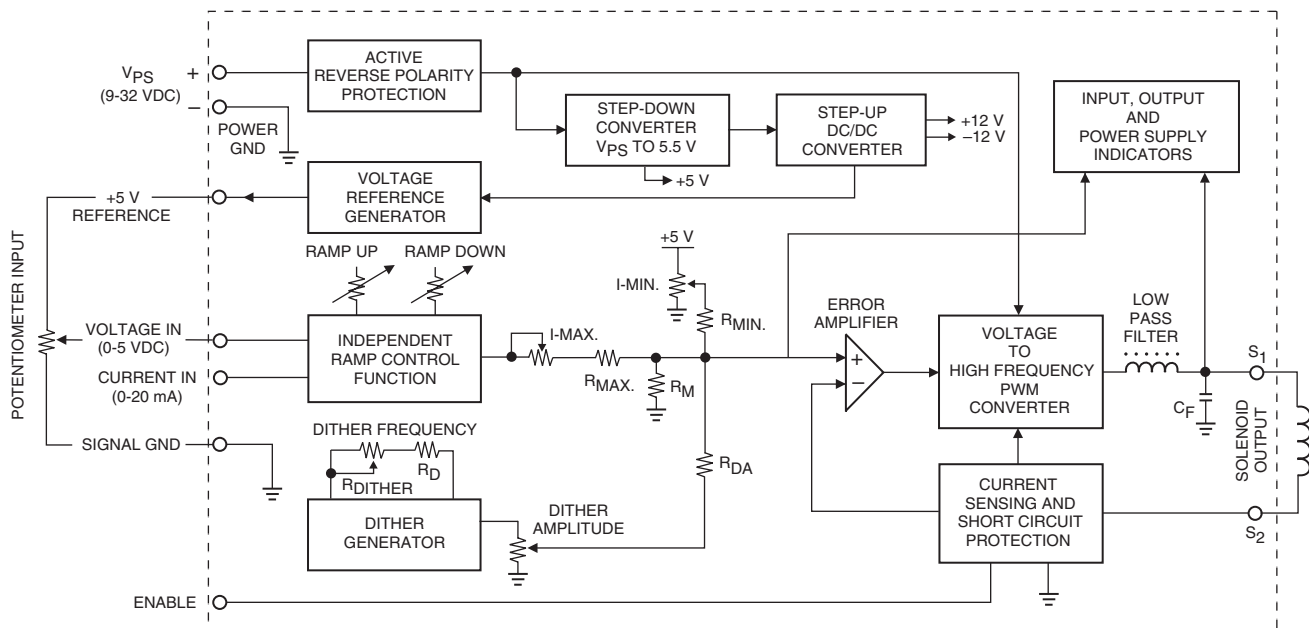

0-5 VDC, 10K Pot or 0-20 mA Input

DIMENSIONS

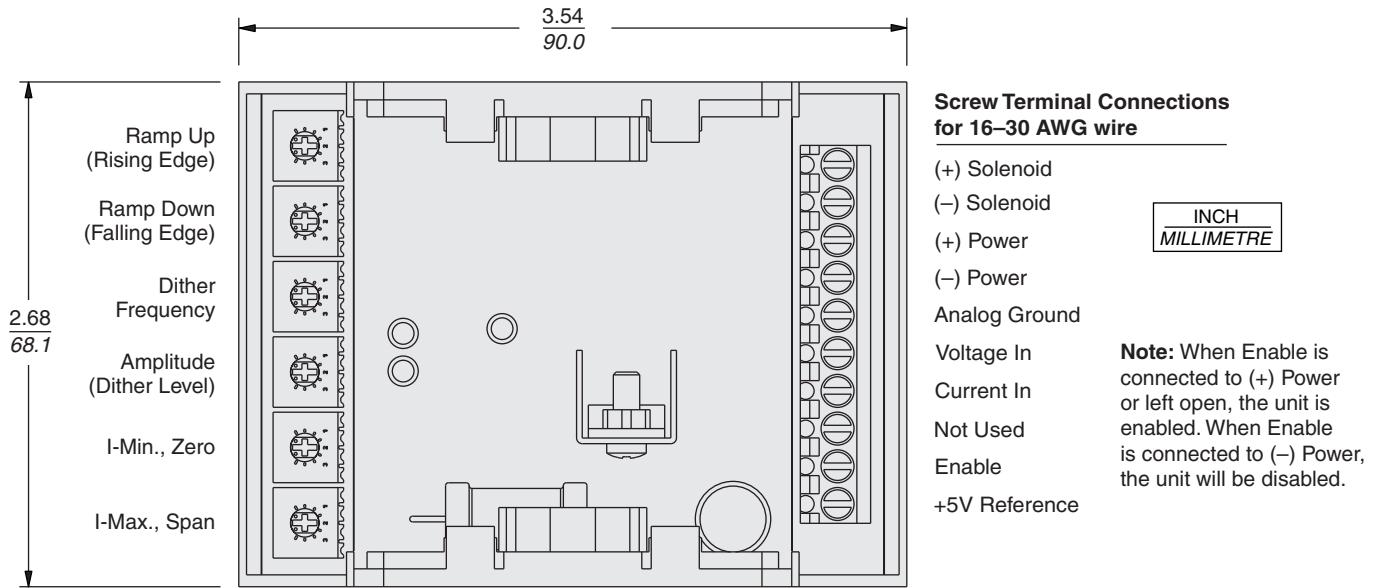

CONNECTIONS

For Complete Set-Up Instructions, see page 3.560.1

For Either 0-20 mA or 0-5 VDC Control: Turn ramp screws fully counterclockwise to eliminate ramping. Use I-Min. screw to set minimum speed with minimum control input. Use I-Max. screw to set maximum speed with 100% of control input.

10K Potentiometer (Pot.) Control

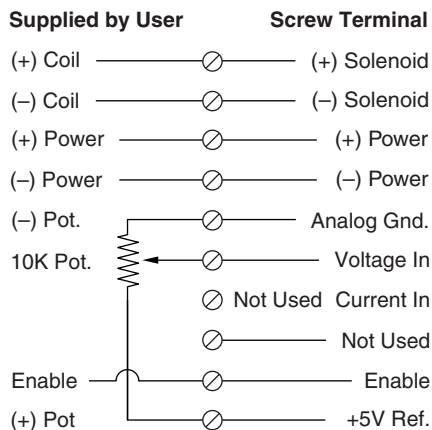

0 to 20 mA Control

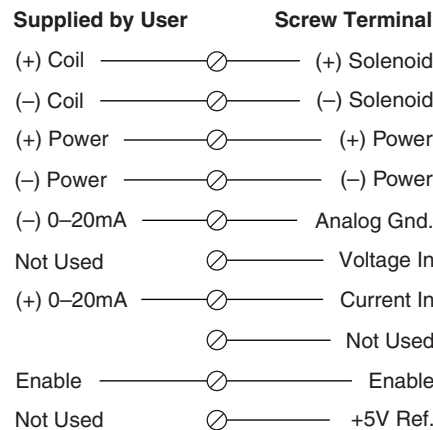

0 to 5 VDC Control

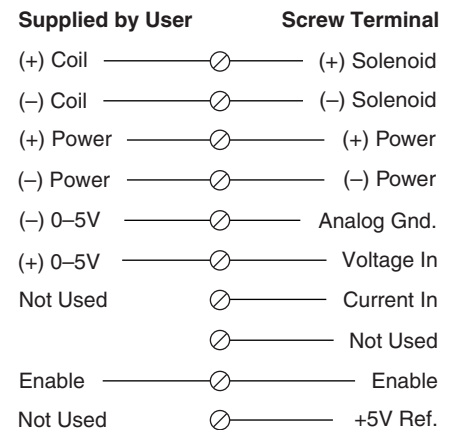

TO ORDER

Part Number	Output	I-Min. Setting	I-Max. Setting
4000136	2000 mA Max.	0 to 500 mA	600 to 2000 mA