

Proportional Valve Controller—Metal Housing—

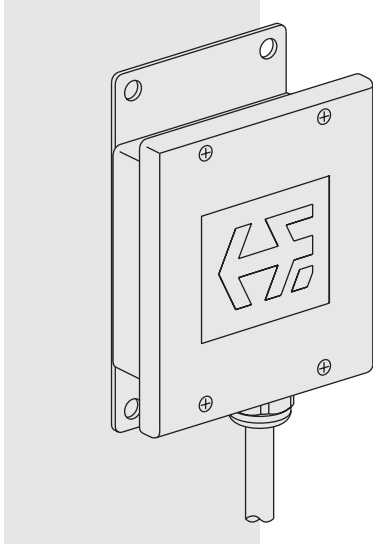

DESCRIPTION 4–20 mA Input

A metal box-style control amplifier for controlling HydraForce proportional valves. The metal housing is IP67 rated. Remote mounting is required. This model is designed for circuits with long wire runs or where electrical interference is a problem.

OPERATION

This control module uses closed-loop current control with superimposed dither to supply a proportional valve solenoid with a proportional control signal. The input signal to this controller can be from a 4–20 mA source.

FEATURES

- Adjustments accessible under removable cover.
- LED indication of output power level, input level and power on/off.
- One unit covers supply voltages from 9 to 32 VDC.
- No internal fuses; circuit limits current electronically.
- Short circuit proof and reverse polarity protected.
- Can be disconnected from coil when powered.
- Maximum current adjustment does not affect minimum current setting.
- Current sensing circuit maintains output current regardless of changes in output voltage or coil resistance.
- Filter eliminates electrical noise; Independent ramp adjustments.
- Dither frequency and amplitude are adjustable for maximum valve performance.

GENERAL SPECIFICATIONS

Metal Housing: Conformal coated; IP67 rated

Weight: Metal Box without cable: 400 g (14.1 oz.)

Connections: Mounted cable with unterminated wires provided; Length: Approx. 1.5 meters (59")

CSA and CE Listings:

CSA C22.2 No. 14-M91

CE: EN 50081-2, EN50082-2

RATINGS

Supply Voltage: 9–32 VDC

Coil rating must be matched with supply voltage: $R_{COIL} \leq (V_{SUPPLY} - 1.5 V) / I_{MAX}$.

Control Input Signal Options: 4–20 mA current signal (see connection diagram)

Input Resistance: 33K Ohms

Output Current: up to 2000 mA (see ordering info.)

Minimum Current Range: 0–500 mA (adjustable; see ordering info.)

Maximum Current Range: 600–2000 mA (adjustable; see ordering info.)

Ramp Up and/or Down: 0.01–5.0 seconds (independently adjustable)

Dither Frequency: 70–350 Hz (adjustable)

Dither Amplitude: 0–10% of maximum current (adjustable)

Operating Conditions: –40° to 85°C; 0 to 85% relative humidity

SCHEMATIC

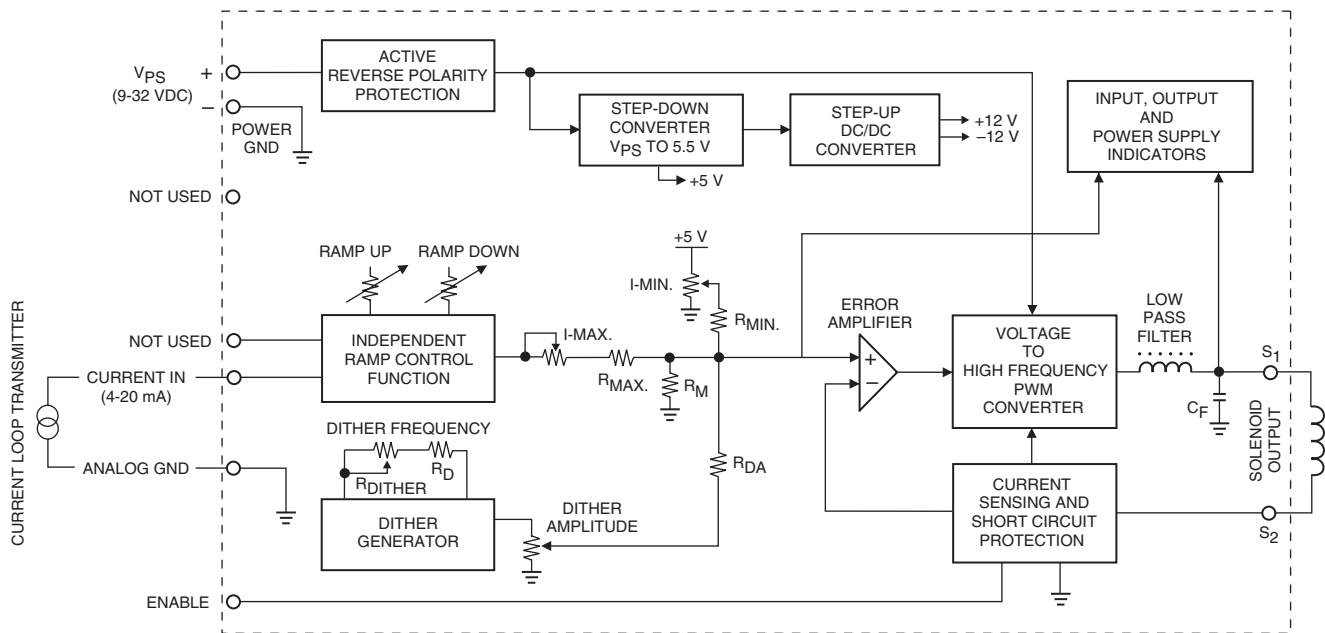

4-20 mA Input

DIMENSIONS

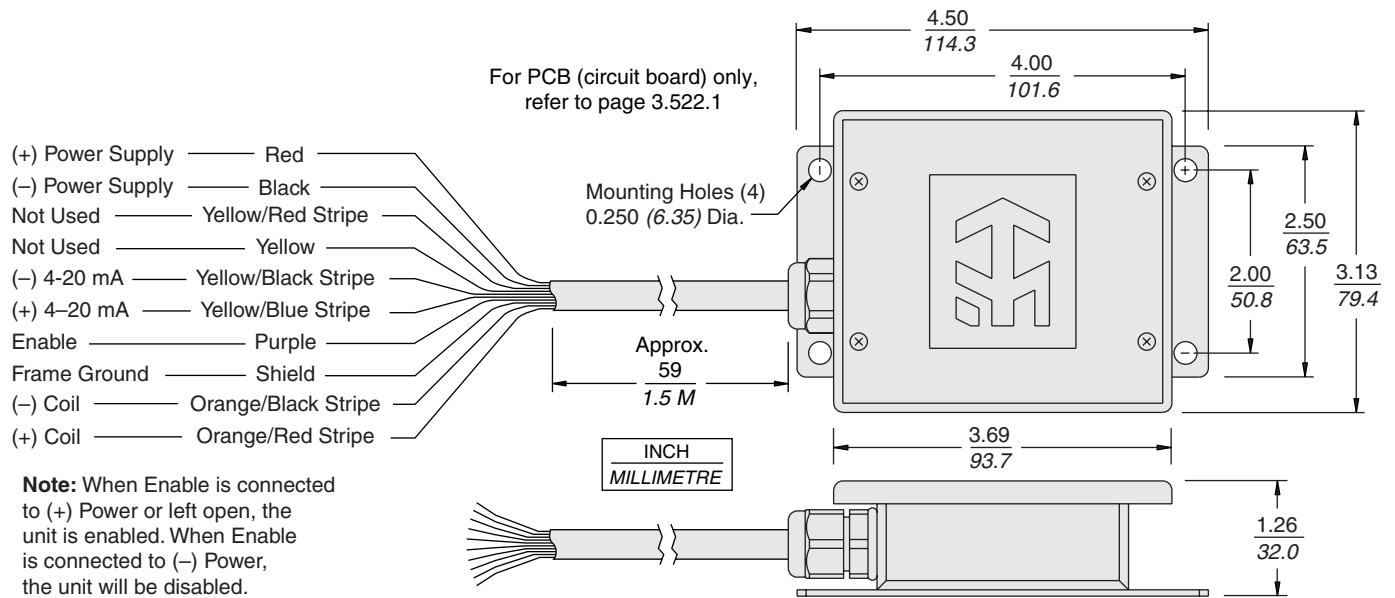

CONNECTIONS

For Complete Set-Up Instructions, see page 3.560.1

Basic Setup: Turn ramp screws fully counterclockwise to eliminate ramping.
 Use I-Min. screw to set minimum speed with minimum control input.
 Use I-Max. screw to set maximum speed with 100% of control input.

4 to 20 mA Control

Supplied by User	Wire Color
(+) Power	Red
(-) Power	Black
Not Used	Yellow/Red Stripe
Not Used	Yellow
(-) 4-20mA	Yellow/Black Stripe
(+) 4-20mA	Yellow/Blue Stripe
Enable	Purple
Frame Gnd.	Shield
(-) Coil	Orange/Black Stripe
(+) Coil	Orange/Red Stripe

TO ORDER

Part Number	Output	I-Min. Setting	I-Max. Setting
4000130	2000 mA Max.	0 to 500 mA	600 to 2000 mA
4000186	1200 mA Max.	0 to 150 mA	400 to 1200 mA