

Proportional Valve Controller—Metal Housing—

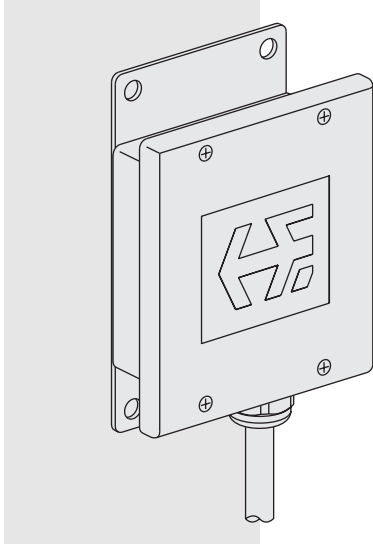

DESCRIPTION *0–10 VDC Input*

A metal box-style control amplifier for controlling HydraForce proportional valves. The metal housing is IP67 rated. Remote mounting is required.

OPERATION

This control module uses closed-loop current control with superimposed dither to supply a proportional valve solenoid with a proportional control signal. The input signal to this controller can be from a 0–10 VDC source.

FEATURES

- Adjustments accessible under removable cover.
- LED indication of output power level, input level and power on/off.
- One unit covers supply voltages from 9 to 32 VDC.
- No internal fuses; circuit limits current electronically.
- Short circuit proof and reverse polarity protected.
- Can be disconnected from coil when powered.
- Maximum current adjustment does not affect minimum current setting.
- Filter eliminates electrical noise.
- Independent ramp adjustments.
- Dither frequency and amplitude are adjustable for maximum valve performance.

RATINGS

Supply Voltage: 9–32 VDC

Coil rating must be matched with supply voltage: $R_{COIL} \leq (V_{SUPPLY} - 1.5 V) / I_{MAX}$.

Control Input Signal: 0–10 VDC

Input Resistance: 250K Ohms

Output Current: up to 2000 mA (see ordering info.)

Minimum Current Range: 0–500 mA (adjustable; see ordering info.)

Maximum Current Range: 600–2000 mA (adjustable; see ordering info.)

Ramp Up and/or Down: 0.01–5.0 seconds (independently adjustable)

Dither Frequency: 70–350 Hz (adjustable)

Dither Amplitude: 0–10% of maximum current (adjustable)

Operating Conditions: –40° to 85°C; 0 to 85% relative humidity

GENERAL SPECIFICATIONS

Metal Housing: Conformal coated; IP67 rated

Weight: Metal Box without cable: 400 g (14.1 oz.)

Connections: Mounted cable with unterminated wires provided; Length: Approx. 1.5 meters (59")

CSA and CE Listings:

CSA C22.2 No. 14-M91

CE: EN 50081-2, EN50082-2

SCHEMATIC

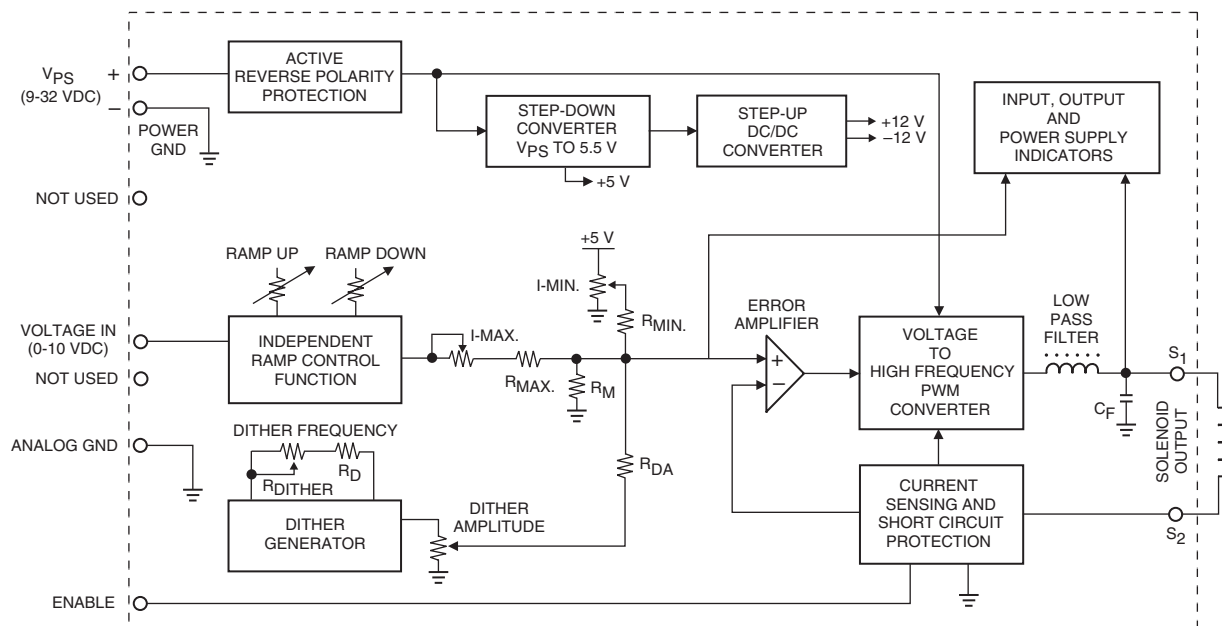

0-10 VDC Input

DIMENSIONS

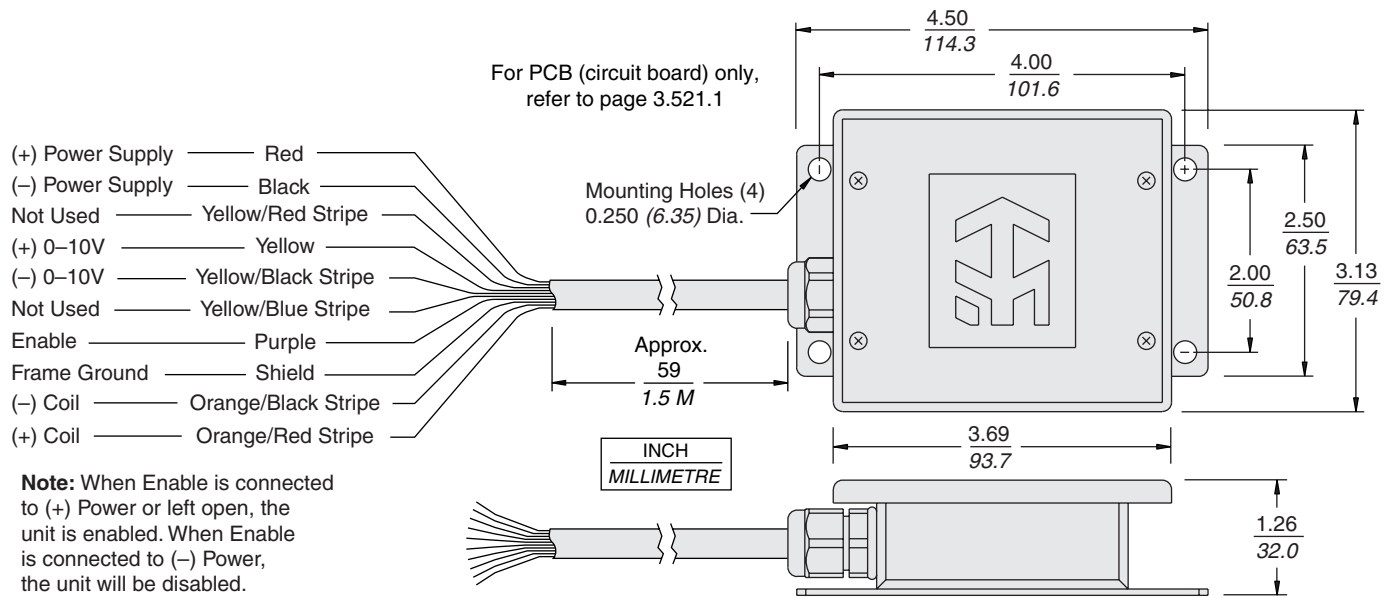

CONNECTIONS

For Complete Set-Up Instructions, see page 3.560.1

Basic Setup: Controller is shipped with ramp trim pots fully counterclockwise to eliminate ramping. Use I-Min. screw to set minimum speed with minimum control input. Use I-Max. screw to set maximum speed with 100% of control input.

0 to 10 VDC Control

Supplied by User	Wire Color
(+) Power	Red
(-) Power	Black
Not Used	Yellow/Red Stripe
(+) 0-10V	Yellow
(-) 0-10V	Yellow/Black Stripe
Not Used	Yellow/Blue Stripe
Enable	Purple
Frame Gnd.	Shield
(-) Coil	Orange/Black Stripe
(+) Coil	Orange/Red Stripe

TO ORDER

Part Number	Output	I-Min. Setting	I-Max. Setting
4000124	2000 mA Max.	0 to 500 mA	600 to 2000 mA
4000182	1200 mA Max.	0 to 150 mA	400 to 1200 mA