

Proportional Valve Controller—PCB Only—

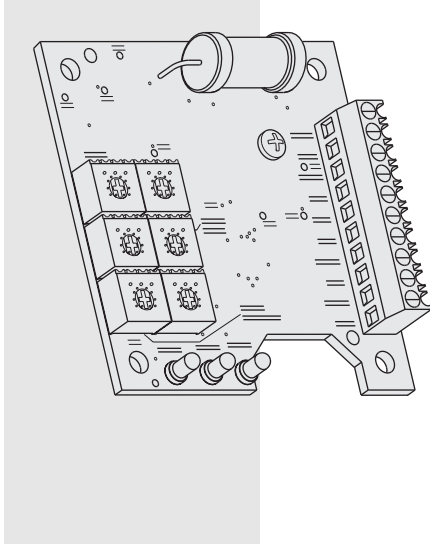

DESCRIPTION *4–20 mA Input*

A printed circuit board-style (PCB) control amplifier for HydraForce proportional valves. Remote mounting in a protected enclosure is required. This model is designed for circuits with long wire runs or where electrical interference is a problem.

OPERATION

This control module uses closed-loop current control with superimposed dither to supply a proportional valve solenoid with a proportional control signal. The input signal to this controller can be from a 4–20 mA source.

FEATURES

- Adjustments and connections clearly labeled.
- LED indication of output power level, input level and power on/off.
- One unit covers supply voltages from 9 to 32 VDC.
- No internal fuses; circuit limits current electronically.
- Short circuit proof and reverse polarity protected.
- Can be disconnected from coil when powered.
- Maximum current adjustment does not affect minimum current setting.
- Current sensing circuit maintains output current regardless of changes in input voltage or coil resistance.
- Filter eliminates electrical noise; Independent ramp adjustments.
- Dither frequency and amplitude are adjustable for maximum valve performance.

GENERAL SPECIFICATIONS

Weight: 25 g (0.88 oz.)

Connections: Screw terminals for 16–30 AWG wire

CSA Listing:
CSA C22.2 No. 14-M91

RATINGS

Supply Voltage: 9–32 VDC

Coil rating must be matched with supply voltage: $R_{COIL} \leq (V_{SUPPLY} - 1.5 V) / I_{MAX}$.

Control Input Signal: 4–20 mA current signal (see connection diagram)

Input Resistance: 50 Ohms

Output Current: up to 2000 mA (see ordering info.)

Minimum Current Range: 0–500 mA (adjustable)

Maximum Current Range: 600–2000 mA (adjustable)

Ramp Up and/or Down: 0.01–5.0 seconds (independently adjustable)

Dither Frequency: 70–350 Hz ($\pm 10\%$)

Dither Amplitude: 0–10% of maximum current (adjustable)

Operating Conditions: –40° to 85°C; 0 to 85% relative humidity

SCHEMATIC

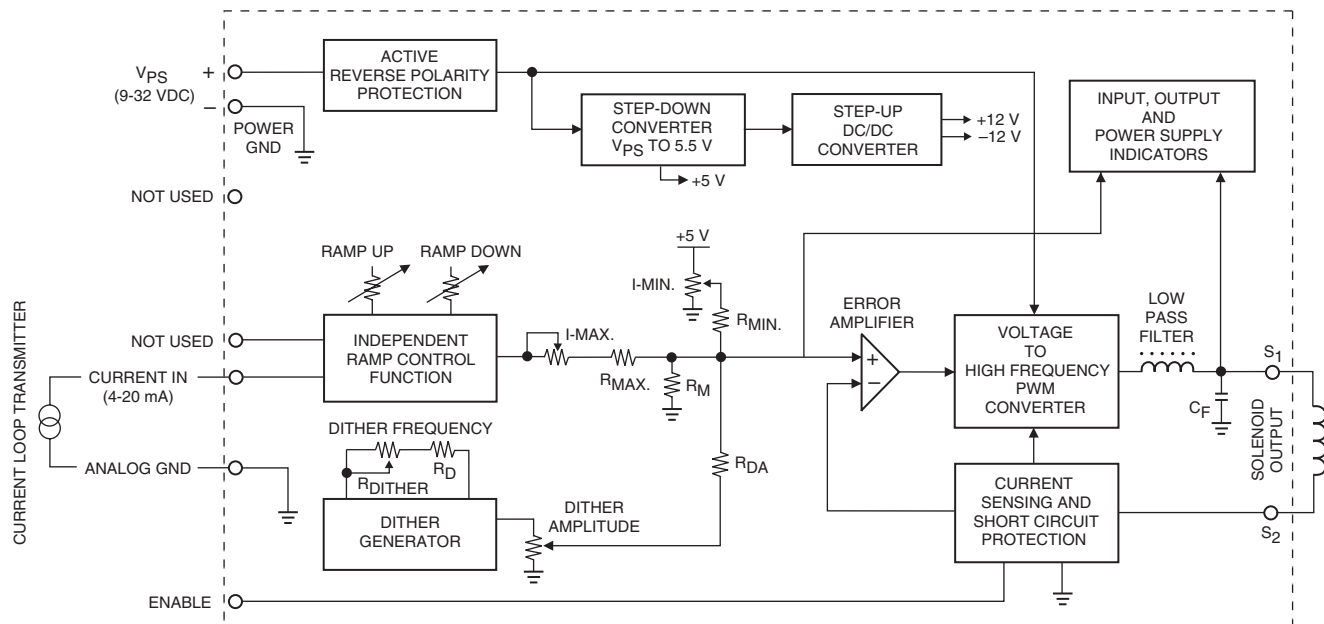

4-20 mA Input

DIMENSIONS

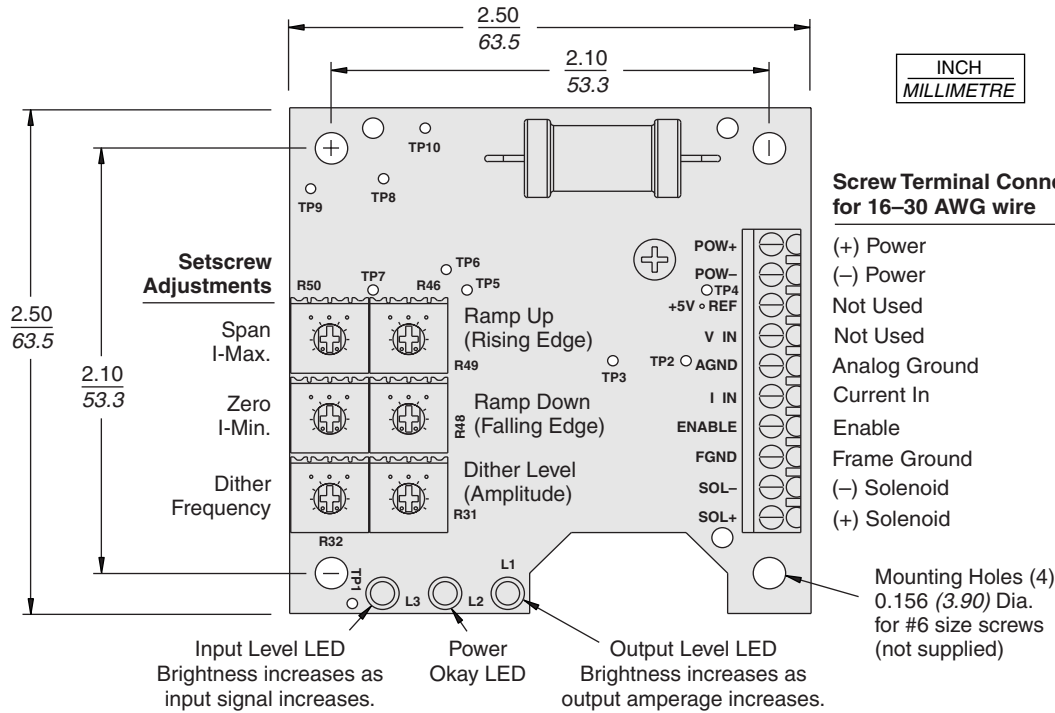

Screw Terminal Connections for 16-30 AWG wire

- (+) Power
- (-) Power
- Not Used
- Not Used
- Analog Ground
- Current In
- Enable
- Frame Ground
- (-) Solenoid
- (+) Solenoid

Note: When Enable is connected to (+) Power or left open, the unit is enabled. When Enable is connected to (-) Power, the unit will be disabled.

CONNECTIONS

For Complete Set-Up Instructions, see page 3.560.1

Basic Setup: Turn ramp screws fully counterclockwise to eliminate ramping. Use I-Min. screw to set minimum speed with minimum control input. Use I-Max. screw to set maximum speed with 100% of control input.

4 to 20 mA Control

Supplied by User	Screw Terminal
(+) Power	(+) Power
(-) Power	(-) Power
Not Used	(+) 5V Reference
Not Used	Voltage In
(-) 4-20mA	Analog Gnd.
(+) 4-20mA	Current In
Enable	Enable
Frame Gnd.	Frame Gnd.
(-) Coil	(-) Solenoid
(+) Coil	(+) Solenoid

TO ORDER

Part Number	Output	I-Min. Setting	I-Max. Setting
4000143	2000 mA Max.	0 to 500 mA	600 to 2000 mA