

Proportional Valve Controller—PCB Only—

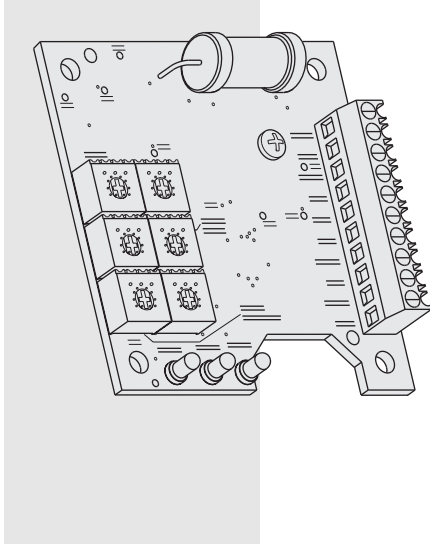

DESCRIPTION *0–10 VDC Input*

A printed circuit board-style (PCB) control amplifier for controlling HydraForce proportional valves. Remote mounting in a protected enclosure is required.

OPERATION

This control module uses closed-loop current control with superimposed dither to supply a proportional valve solenoid with a proportional control signal. The input signal to this controller can be from a 0–10 VDC source.

FEATURES

- Adjustments and connections clearly labeled.
- LED indication of output power level, input level and power on/off.
- One unit covers supply voltages from 9 to 32 VDC.
- No internal fuses; circuit limits current electronically.
- Short circuit proof and reverse polarity protected.
- Can be disconnected from coil when powered.
- Maximum current adjustment does not affect minimum current setting.
- Independent ramp adjustments.
- Filter eliminates electrical noise.
- Dither frequency and amplitude are adjustable for maximum valve performance.

RATINGS

Supply Voltage: 9–32 VDC

Coil rating must be matched with supply voltage: $R_{COIL} \leq (V_{SUPPLY} - 1.5 V) / I_{MAX}$.

Control Input Signal: 0–10 VDC

Input Resistance: 250K Ohms

Output Current: up to 2000 mA (see ordering info.)

Minimum Current Range: 0–500 mA (adjustable)

Maximum Current Range: 600–2000 mA (adjustable)

Ramp Up and/or Down: 0.01–5.0 seconds (independently adjustable)

Dither Frequency: 70–350 Hz ($\pm 10\%$)

Dither Amplitude: 0–10% of maximum current (adjustable)

Operating Conditions: -40° to 85°C ; 0 to 85% relative humidity

GENERAL SPECIFICATIONS

Weight: 25 g (0.88 oz.)

Connections: Screw terminals for 16–30 AWG wire

CSA Listing:
CSA C22.2 No. 14-M91

SCHEMATIC

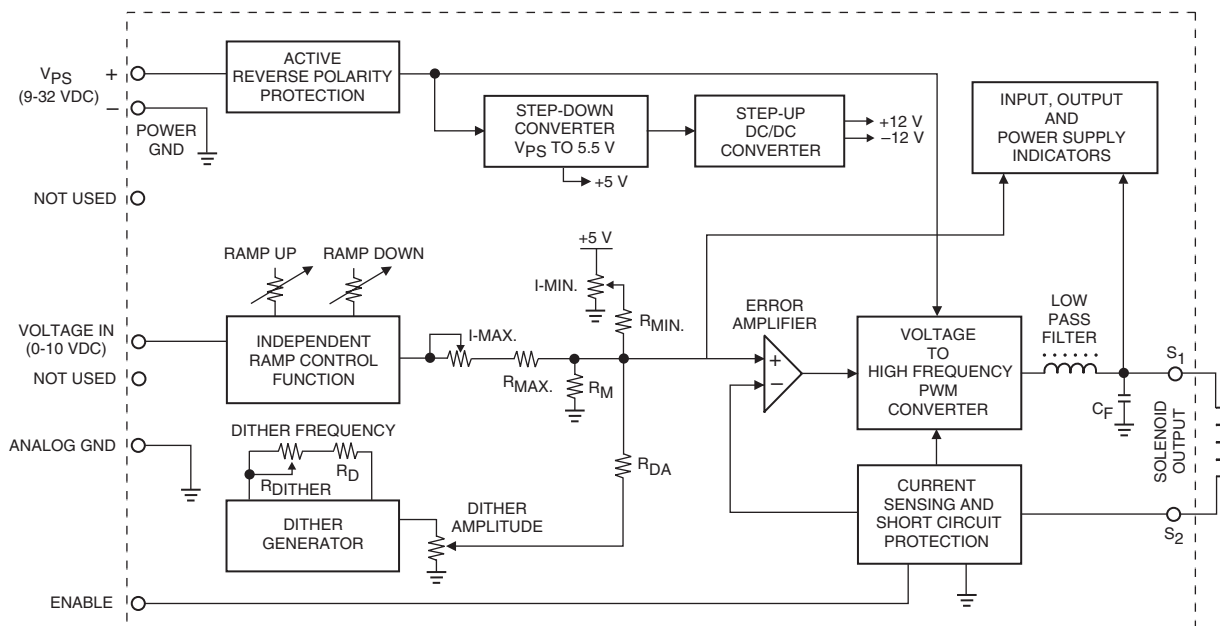

0-10 VDC Input

DIMENSIONS

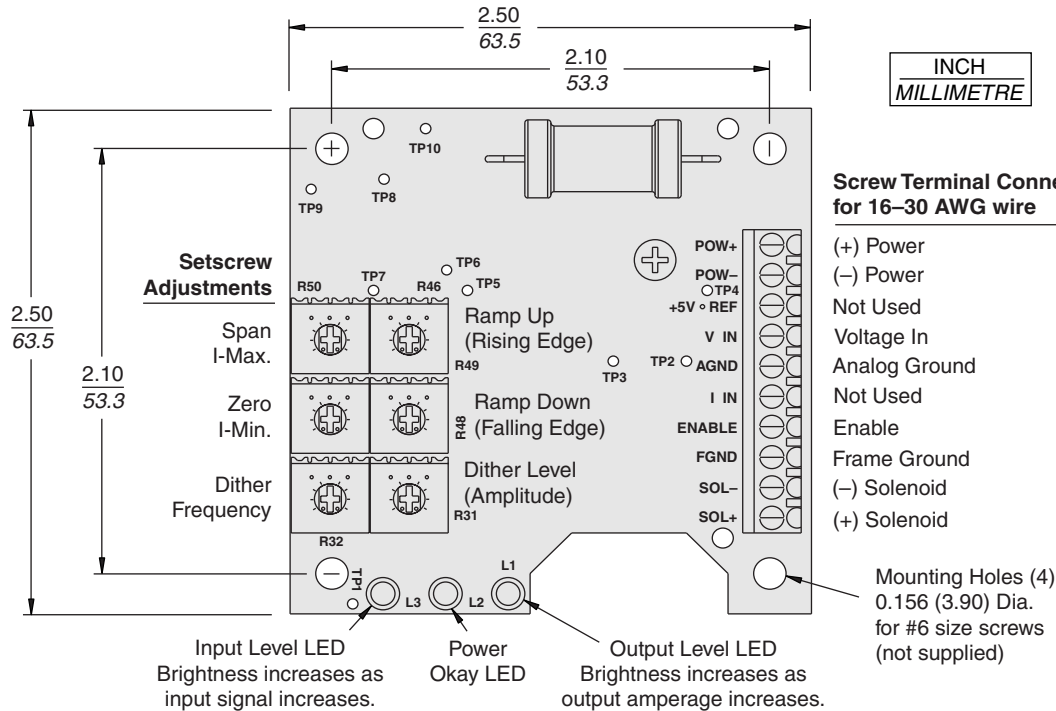

Screw Terminal Connections for 16-30 AWG wire

Note: When Enable is connected to (+) Power or left open, the unit is enabled. When Enable is connected to (-) Power, the unit will be disabled.

CONNECTIONS

For Complete Set-Up Instructions, see page 3.560.1

Basic Setup: Controller is shipped with ramp trim pots fully counterclockwise to eliminate ramping. Use I-Min. screw to set minimum speed with minimum control input. Use I-Max. screw to set maximum speed with 100% of control input.

0 to 10 VDC Control

Supplied by User	Screw Terminal
(+) Power	(+) Power
(-) Power	(-) Power
Not Used	(+) 5V Reference
(+) 0-10V	Voltage In
(-) 0-10V	Analog Gnd.
Not Used	Current In
Enable	Enable
Frame Gnd.	Frame Gnd.
(-) Coil	(-) Solenoid
(+) Coil	(+) Solenoid

TO ORDER

Part Number	Output	I-Min. Setting	I-Max. Setting
4000141	2000 mA Max.	0 to 500 mA	600 to 2000 mA