

DIRECTIONAL VALVES

MR10-47C Manual Rotary, 4-Way, 3-Pos., Closed Center

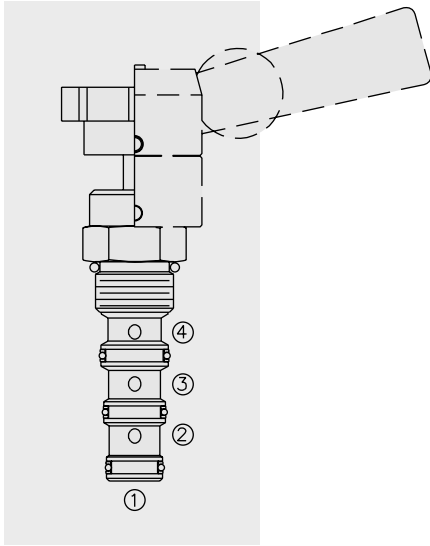

DESCRIPTION

Manually-operated four-way, three-position directional valve, with adaptability to a variety of adjustment operators (ordered separately), in a variety of spool configurations.

OPERATION

Three positions: centered, 45° counterclockwise, and 45° clockwise. In the center position all ports are closed. In the 45° counterclockwise from center position, ports ① and ④ are open while ports ② and ③ are open. In the 45° clockwise from center position, ports ① and ② are open while ports ③ and ④ are open. All ports are closed in transition.

FEATURES

- Three-position detent, friction lock (with detented neutral), or spring return operators may be ordered separately.
- May be fully pressurized at all ports.
- Optional lock-down bracket.
- Heavy-duty construction.
- Industry common cavity.

RATINGS

Operating Pressure: 240 bar (3500 psi)

Max. Flow: See Performance Chart

Internal Leakage: 164 cc/minute (10 cu. in./minute) at 240 bar (3500 psi)

Temperature: -40 to 120°C with standard Buna N seals

Fluids: Mineral-based or synthetics with lubricating properties at viscosities of 7.4 to 420 cSt (50 to 2000 ssu)

Installation: No position restrictions; See page 9.020.1

See page 4.990.2 for operator handles/knobs installation;

See page 4.990.1 for lock-down bracket installation.

Cavity: VC10-4; See page 9.110.1

Cavity Tool: CT10-4XX; See page 8.600.1

Seal Kit: SK10-4X-MMM; See page 8.650.1

Lock-Down Bracket Kit: Part Number 5399000

SYMBOLS

USAS/ISO:

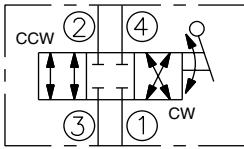

TRANSITION:

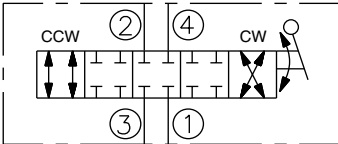

PERFORMANCE (Cartridge Only)

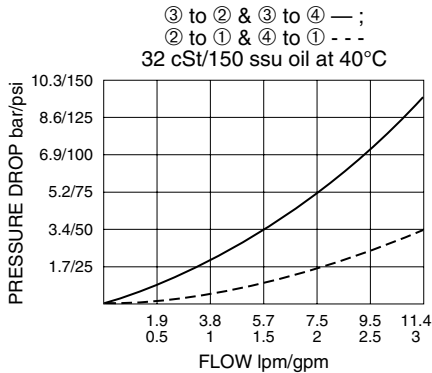

MR10-47C

DIMENSIONS

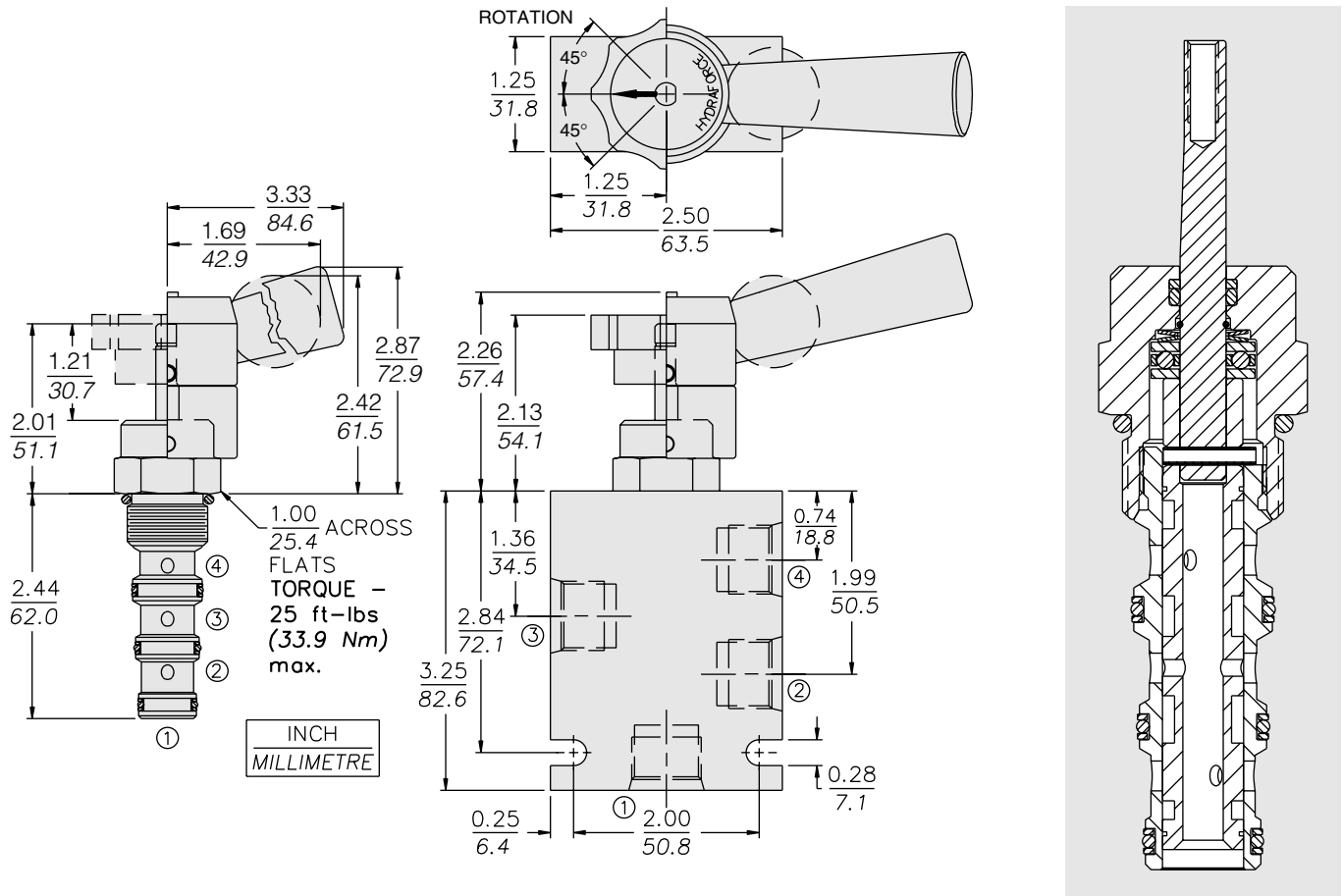

MATERIALS

Cartridge: Weight: 0.13 kg. (0.29 lbs.); Steel with hardened work surfaces. Zinc-plated exposed surfaces. Buna N O-rings and Fluorocarbon back-ups standard.

Standard Ported Body: Weight: 0.34 kg. (0.75 lbs.); Anodized high-strength 6061 T6 aluminum alloy, rated to 240 bar (3500 psi); see page 8.010.1. Ductile iron and steel bodies available; dimensions may differ; consult factory.

Lever-Type Handle: (Sold Separately) Weight: 0.18 kg. (0.38 lbs.). Steel with hardened work surfaces. Zinc-plated exposed surfaces. Plastic lever arm.

TO ORDER

MR10-47C

Option

None (Blank)

Porting

Cartridge Only **0**
 SAE 6 **6T**
 SAE 8 **8T**
 SAE 8 with Lock-Down Bracket **8TL**
 1/4 in. BSP* **2B**
 3/8 in. BSP* **3B**

Seals

N Buna N (Std.)
V Fluorocarbon

NOTE: To order standard operator kits, refer to pages 4.770.1 and 4.770.2

*BSP Body; U.K. Mfr. Only