

DIRECTIONAL VALVES

MR10-41 Manual Rotary 4-Way, 2-Pos. Directional Valve

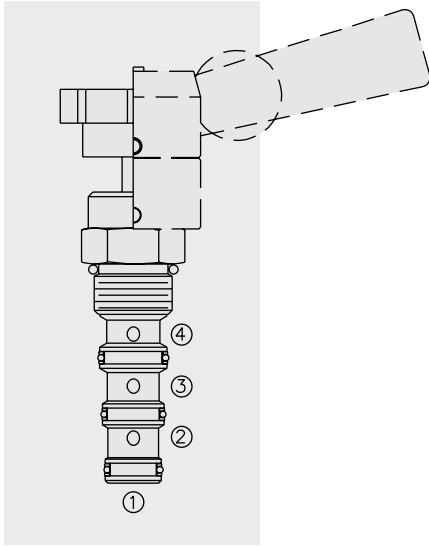

DESCRIPTION

A manually-operated four-way, two-position directional valve, with adaptability to a variety of adjustment operators (ordered separately).

OPERATION

Two positions, 90° rotation. In extreme counterclockwise position all ports are closed. In extreme clockwise position, ports ① and ④ are open while ports ② and ③ are open. All ports are closed in transition.

FEATURES

- Two-position detent, infinite friction lock, or spring return operators may be ordered separately.
- May be fully pressurized at all ports.
- Optional lock-down bracket.
- Heavy-duty construction.
- Industry common cavity.

RATINGS

Operating Pressure: 240 bar (3500 psi)

Max. Flow: See Performance Chart

Internal Leakage: 164 cc/minute (10 cu. in./minute) at 240 bar (3500 psi)

Temperature: -40 to 120°C with standard Buna N seals

Fluids: Mineral-based or synthetics with lubricating properties at viscosities of 7.4 to 420 cSt (50 to 2000 ssu)

Installation: No position restrictions; See page 9.020.1

See page 4.990.2 for operator handles/knobs installation;

See page 4.990.1 for lock-down bracket installation.

Cavity: VC10-4; See page 9.110.2

Cavity Tool: CT10-4XX; See page 8.600.1

Seal Kit: SK10-4X-MMM; See page 8.650.1

Lock-Down Bracket Kit: Part Number 5399000

SYMBOLS

USASI/ISO:

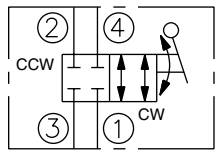

TRANSITION:

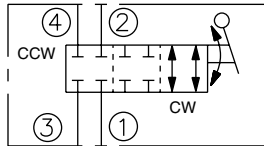

PERFORMANCE (Cartridge Only)

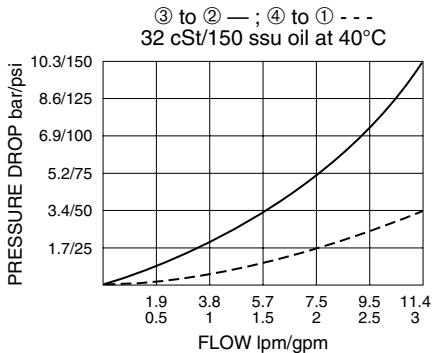

MR10-41

DIMENSIONS

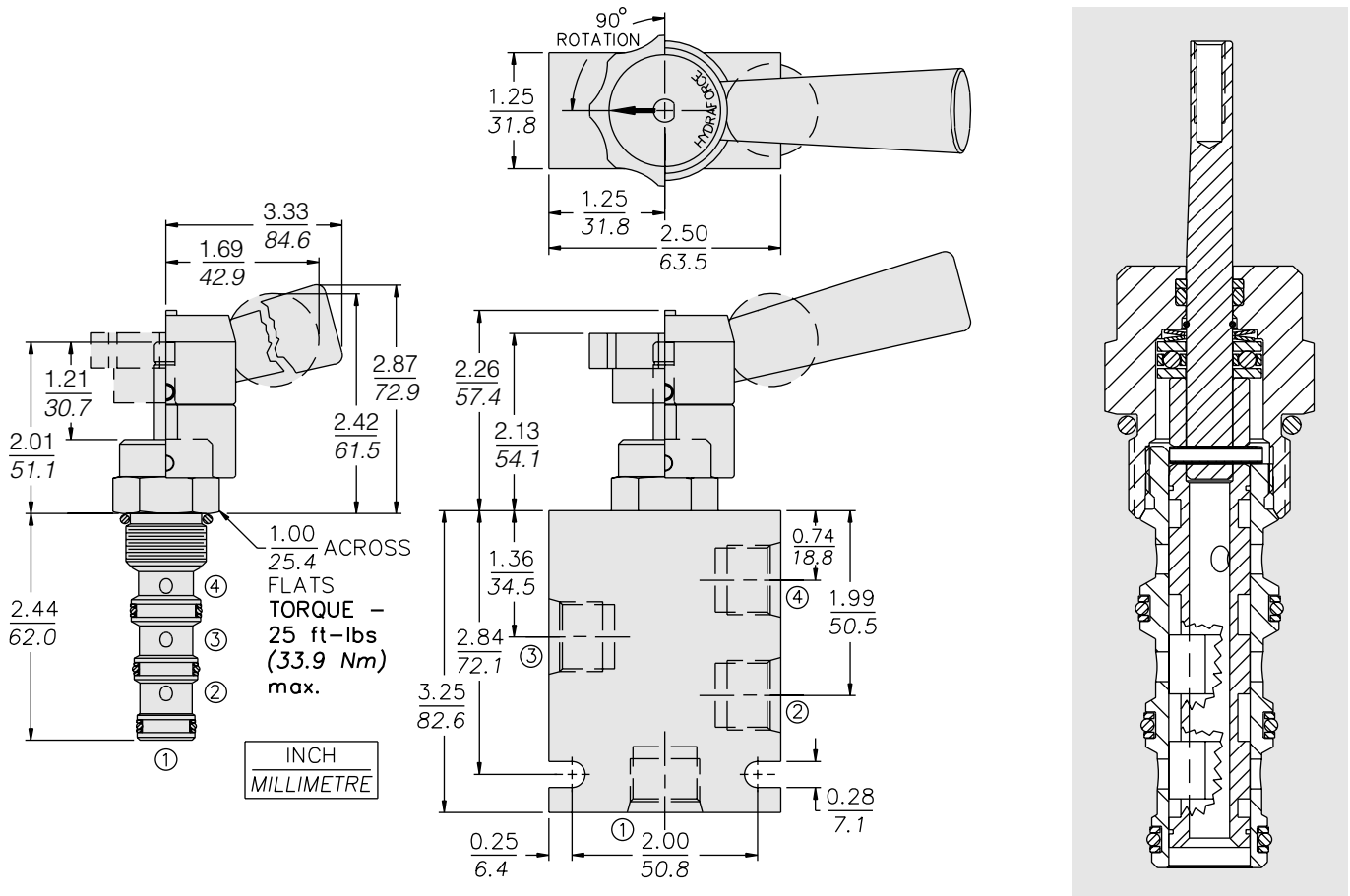

MATERIALS

Cartridge: Weight: 0.13 kg. (0.29 lbs.); Steel with hardened work surfaces. Zinc-plated exposed surfaces. Buna N O-rings and Fluorocarbon back-ups standard.

Standard Ported Body: Weight: 0.34 kg. (0.75 lbs.); Anodized high-strength 6061 T6 aluminum alloy, rated to 240 bar (3500 psi); see page 8.010.1. Ductile iron and steel bodies available; dimensions may differ; consult factory.

Lever-Type Handle: (Sold Separately) Weight: 0.18 kg. (0.38 lbs.); Steel with hardened work surfaces. Zinc-plated exposed surfaces. Plastic lever arm.

TO ORDER

MR10-41		-	-
Option	None (Blank)		
Porting	Cartridge Only	0	
	SAE 6	6T	
	SAE 8	8T	
	SAE 8 with Lock-Down Bracket	8TL	
	1/4 in. BSP*	2B	
	3/8 in. BSP*	3B	
Seals	N Buna N (Std.)		
	V Fluorocarbon		

NOTE: To order standard operator kits, refer to pages 4.770.1 and 4.770.2

*BSP Body; U.K. Mfr. Only