

DIRECTIONAL VALVES

PE42-S67C Proportional, Pilot Operated

U.S. Patent
6,554,014

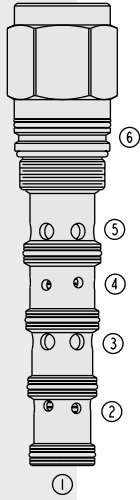

DESCRIPTION

A screw-in, cartridge-style, proportional, spring-centered, pilot-operated spool-type hydraulic directional valve.

OPERATION

When the PE42-S67C is in neutral position all ports are blocked. When the remote pilot signal at ① exceeds the force of the bias spring, the spool shifts proportionally to allow flow from ③ to ④ through a load such as a hydraulic cylinder or motor, and from ② to ⑤ and to tank. When the pilot signal at ⑥ exceeds the force of the bias spring the spool shifts proportionally to the applied force to allow flow from ③ to ② and from ④ to ⑤. When the pilot signal is less than the force of the bias spring, the spool will return to the center position. **The valve's spool is symmetrical, providing meter-in and meter-out control.**

FEATURES

- Hardened spool and cage for long life.
- Cost-effective cavity.
- Excellent metering characteristics.
- Good linearity.

RATINGS

Maximum Operating Pressure: Port ③: 345 bar (5000 psi)
Ports ② and ④: 240 bar (3500 psi)
Ports ① and ⑥: 27.6 bar (400 psi)

Flow: 0–170 lpm (0–45 gpm); See Performance Chart

Internal Leakage: 590 cc/minute (36 cu. in./minute) at 207 bar (3000 psi)

Temperature: -40 to 120°C with Buna N seals

Filtration: See page 9.010.1

Fluids: Mineral-based or synthetics with lubricating properties at viscosities of 7.4 to 420 cSt (50 to 2000 ssu)

Installation: No restrictions; See page 9.020.1

Cavity: VC42-S6; See page 9.142.1

Cavity Tool: CT42-S6; See page 8.600.1

Seal Kit: SK42-S6X-BMMMM; See page 8.650.1

SYMBOLS

USASI:

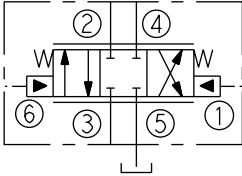

ISO:

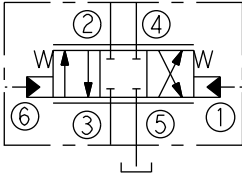

PERFORMANCE (Cartridge Only)

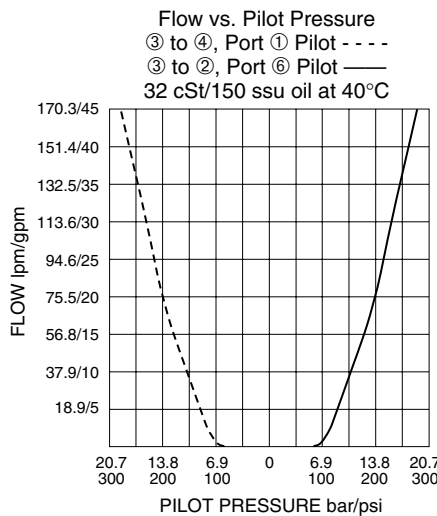
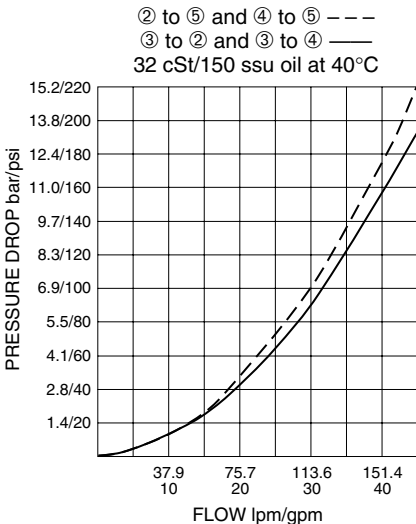

DIMENSIONS

U.S. Patent 6,554,014

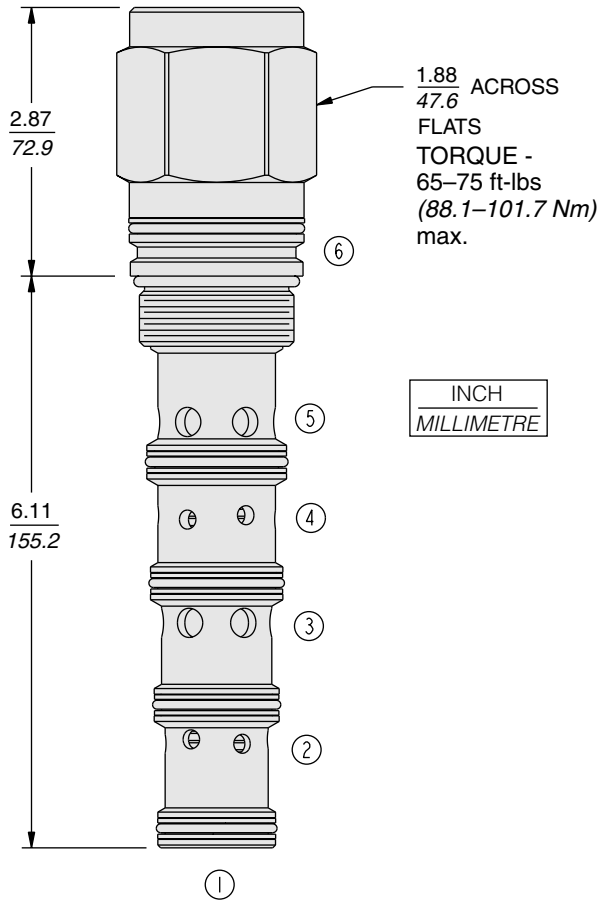

MATERIALS

Cartridge: Weight: 0.76 kg. (1.68 lbs.);
Steel with hardened work surfaces.
Zinc-plated exposed surfaces.
Buna N O-rings and polyester
elastomer back-ups standard.

Test Body: Consult Factory

TO ORDER

PE42-S67C - -

Porting
Cartridge Only **0**

Seals

- N** Buna N (Std.)
- P** Polyurethane (for pressures over 240 bar/3500 psi)
- V** Fluorocarbon