

DIRECTIONAL VALVES

PD12-S50 Piloted 3-Way Spool with Vented Spring

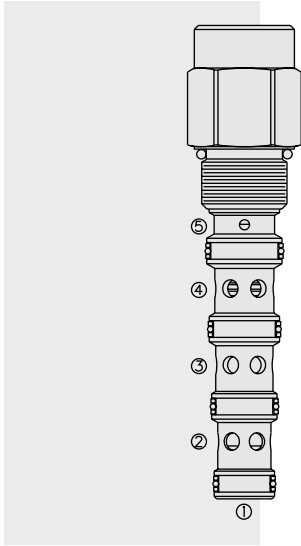

DESCRIPTION

A screw-in, cartridge-style, pilot-operated, spool-type, hydraulic directional valve for three-way circuits requiring remote pilot actuation.

OPERATION

In neutral (unpiloted), the PD12-S50 allows flow from ③ to ② bidirectionally, while flow is blocked at ④.

On remote pilot signal at ①, the valve shifts to open ③ to ④ while blocking ②.

The spring chamber is vented to the tank through port ⑤, which is, optionally, O-ring sealed from the cartridge flow paths. The vented spring chamber allows the valve to be fully pressurized at ports ①, ② and ③ without affecting required pilot pressure. Pressure at ⑤ will affect required pilot pressure.

FEATURES

- Hardened spool and cage for long life.
- Optional sealed pilot and spring chamber.

RATINGS

Maximum Operating Pressure: 241 bar (3500 psi)

Flow: See Performance Chart

Internal Leakage: 164 cc/minute (10 cu. in./minute) on all flow ports at maximum operating pressure. The sealed pilot version exhibits no leakage at ports ① and ⑤ at maximum pressure.

Oil Volume Required to Full Shift: 1.07 cc (0.065 cu. in.)

Temperature: -40 to 120°C with standard Buna seals

Filtration: See page 9.010.1

Fluids: Mineral-based or synthetics with lubricating properties at viscosities of 7.4 to 420 cSt (50 to 2000 ssu)

Installation: No restrictions; See page 9.020.1

Cavity: VC12-S5; See page 9.112.1

Cavity Tool: CT12-S5; See page 8.600.1

Seal Kit: SK12-S5X-MMMM; See page 8.650.1

SYMBOLS

USASI:

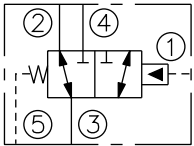

ISO:

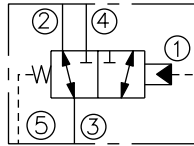

PERFORMANCE (Cartridge Only)

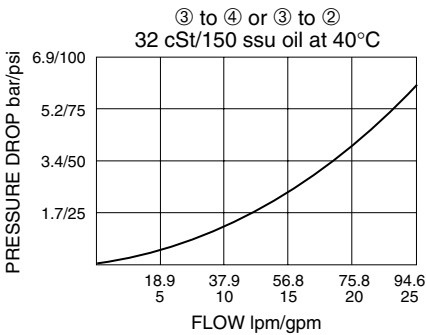

Chamber

PD12-S50

DIMENSIONS

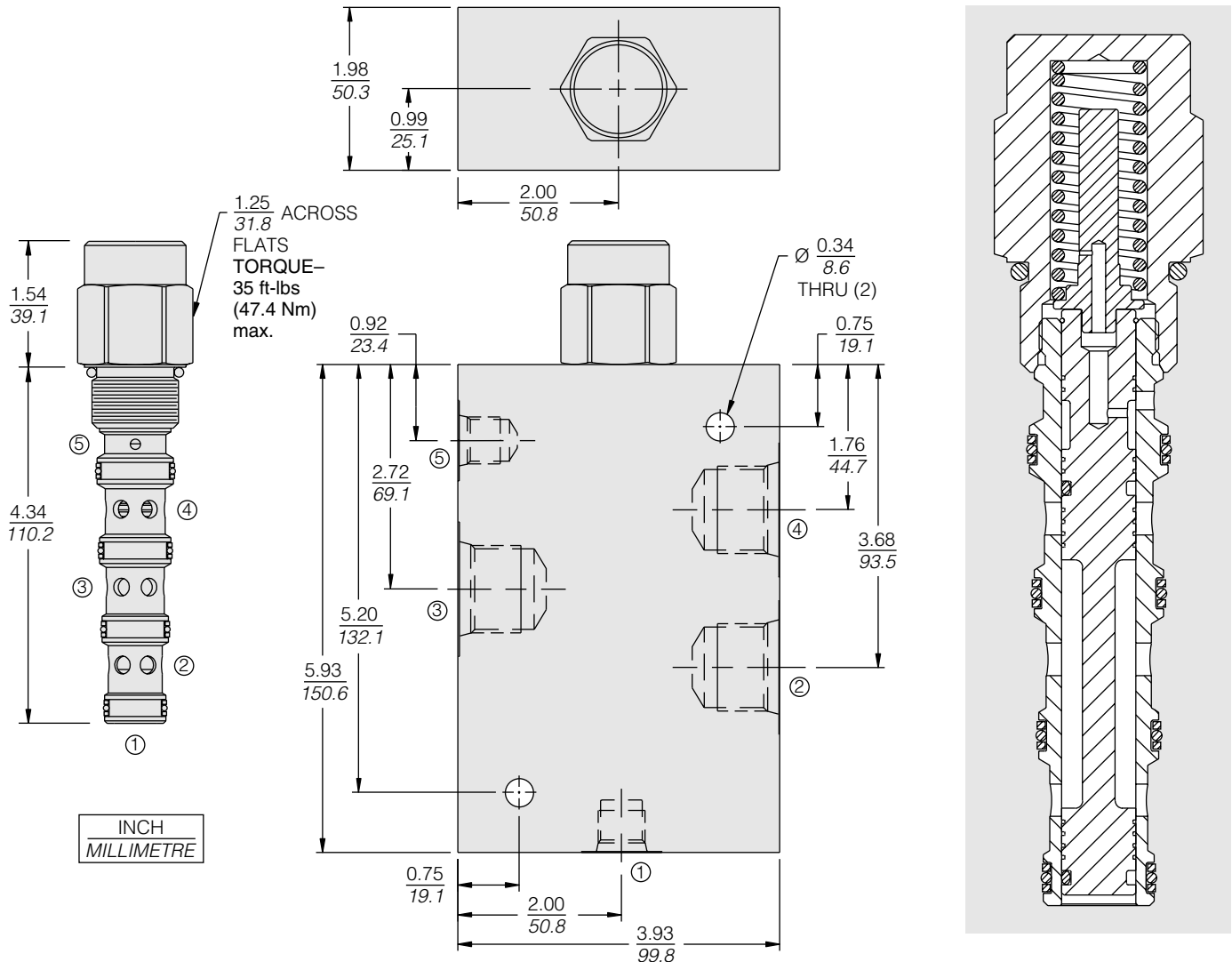

MATERIALS

Cartridge: Weight: 0.375 kg. (0.83 lbs.); Steel with hardened work surfaces. Zinc-plated exposed surfaces. Buna N O-rings and polyester elastomer back-ups standard.

Standard Ported Body: Weight: 1.5 kg. (3.3 lbs.); Anodized high-strength 6061 T6 aluminum alloy, rated to 240 bar (3500 psi); see page 8.012.1. Ductile iron and steel bodies available; dimensions may differ; consult factory.

TO ORDER

PD12-S50-	-110*	
		*110 psi bias spring standard. Optional bias springs considered on OEM request.
Porting		Seals
Cartridge Only	0	N Buna N (Std.)
SAE 10, SAE 6 Pilot	10T	NS Buna N with Sealed Pilot
SAE 12, SAE 6 Pilot	12T	V Fluorocarbon
		VS Fluorocarbon with Sealed Pilot

Note: All bodies are PD type.