

DIRECTIONAL VALVES

PD42-M42 Piloted 3-Way Spool, Internal Vent

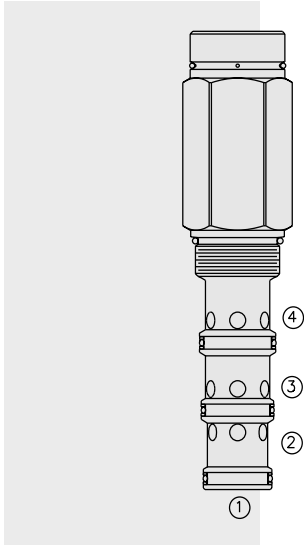

DESCRIPTION

A screw-in, cartridge-style, pilot-operated, spool-type, hydraulic directional valve for three-way circuits requiring remote pilot actuation.

OPERATION

In neutral (unpiloted), the PD42-M42 allows flow passage between ③ and ②. ④ is blocked.

On remote pilot signal at ①, the valve shifts to open from ③ to ④, while blocking flow to ②.

Note that ④ is common to the spring chamber. Pressure on ④ will directly (1:1) affect required pilot pressure and must always be added to the bias spring value.

Note: Consult factory for applications where bi-directional flow is required when the valve is in the normal or spring-offset position.

FEATURES

- Hardened spool and cage for long life.
- Optional sealed pilot.
- Industry-standard ISO cavity.

RATINGS

Maximum Operating Pressure: With Polyurethane Seals: Ports ①, ②, & ③: 345 bar (5000 psi); Port ④: 210 bar (3000 psi)

Flow: See Performance Chart

Internal Leakage at Maximum Operating Pressure: All Ports : 246 cc/minute (15 cu. in./minute); The sealed pilot version exhibits no leakage at maximum operating pressure.

Pilot Pressure Required:

- To Begin Spool Movement: 11.9 bar (172 psi)
- To Bring Spool to Cross-Over Point: 14.5 bar (210 psi)
- To Fully Shift the Spool: 17 bar (245 psi)

Oil Volume Required to Full Shift: 2.5 cc (0.15 cu. in.)

Temperature: -40 to 120°C with standard Buna seals

Filtration: See page 9.010.1

Fluids: Mineral-based or synthetics with lubricating properties at viscosities of 7.4 to 420 cSt (50 to 2000 ssu)

Installation: No restrictions; See page 9.020.1

Cavity: VC42-M4; See page 9.142.1

Cavity Tool: CT42-M4XX; See page 8.600.1

Seal Kit: SK42-4X-MMM; See page 8.650.1

SYMBOLS

USASI:

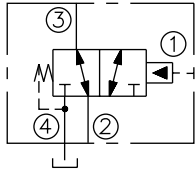

ISO:

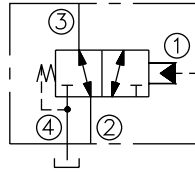

OPEN TRANSITION:

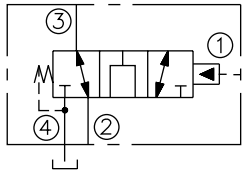

PERFORMANCE (Cartridge Only)

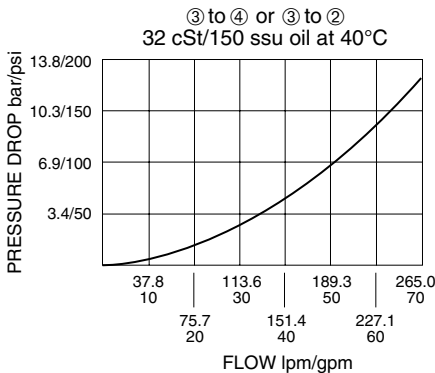

PD42-M42

DIMENSIONS

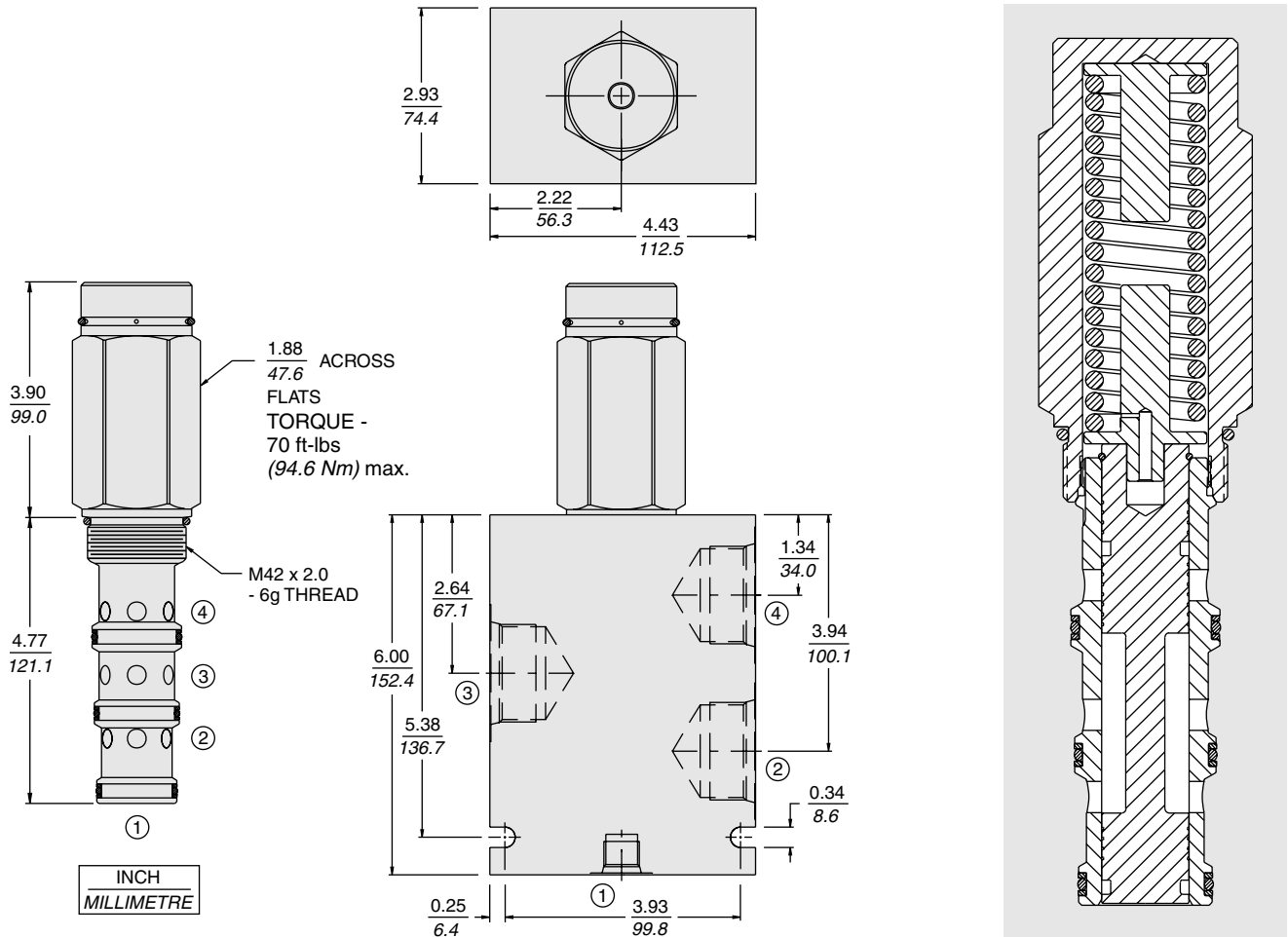

MATERIALS

Cartridge: Weight: 0.52 kg. (1.15 lbs.); Steel with hardened work surfaces. Zinc-plated exposed surfaces. Buna N O-rings and polyester elastomer back-ups standard.

Standard Ported Body: Weight: 1.5 kg. (3.3 lbs.); Anodized high-strength 6061 T6 aluminum alloy, rated to 240 bar (3500 psi); see page 8.042.1. Ductile iron and steel bodies available; Dimensions may differ; consult factory.

TO ORDER

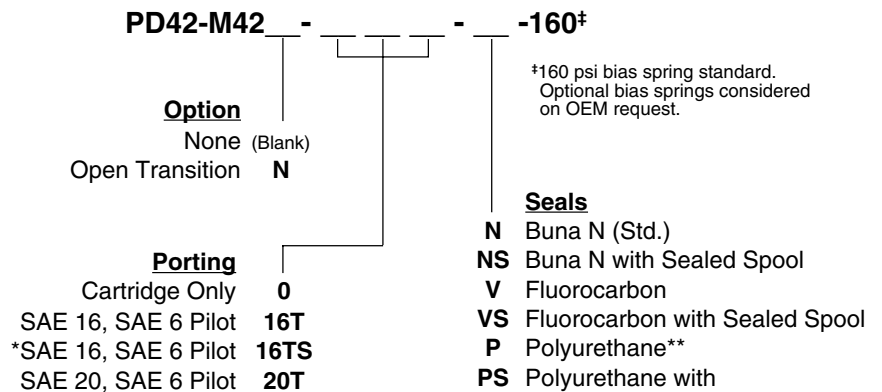

*Steel body for pressures over 3500 psi

Note: All bodies are PD type.