

DIRECTIONAL VALVES

PD10-35 Piloted 2-Way Spool, Normally Open,

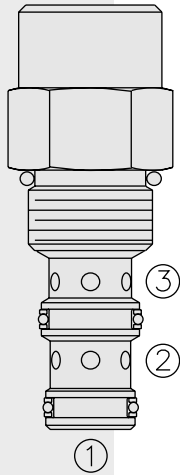

DESCRIPTION

A screw-in, cartridge-style, pilot-operated, spool-type, normally open hydraulic directional valve for two-way circuits requiring remote pilot actuation.

OPERATION

In neutral (unpiloted), the **PD10-35** allows flow from ② to ③. The spring bias chamber is internally vented to ③.

On remote pilot signal at ①, the valve shifts to block ③ to ② bidirectionally.

Note: Back pressure at ③ will increase the pilot pressure required at ① to shift, at a ratio of 1:1. Consult factory.

Consult factory for applications where bi-directional flow is required when the valve is in the normal or spring-offset position.

FEATURES

- Hardened spool and cage for long life.
- Industry common cavity.

RATINGS

Operating Pressure: 240 bar (3500 psi)

Proof Pressure: 390 bar (5700 psi)

Flow: See Performance Chart

Internal Leakage: 82 cc/minute (5 cu. in./minute) max. at 207 bar (3000 psi)

Pilot Pressure Required: To Full Spool Shift
for 4.1 bar (60 psi) spring: 4.7 bar (68.2 psi)
for 7.6 bar (110 psi) spring: 8.6 bar (125 psi)

Oil Volume Required to Full Shift: 0.65 cc (0.04 cu. in.)

Temperature: -40 to 120°C with standard Buna seals

Filtration: See page 9.010.1

Fluids: Mineral-based or synthetics with lubricating properties at viscosities of 7.4 to 420 cSt (50 to 2000 ssu)

Installation: No restrictions; See page 9.020.1

Cavity: VC10-3; See page 9.110.1

Cavity Tool: CT10-3XX; See page 8.600.1

Seal Kit: SK10-3X-MM; See page 8.650.1

SYMBOLS

USASI:

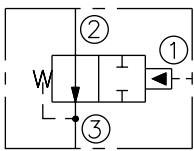

ISO:

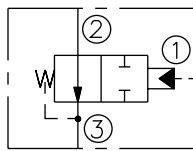

PERFORMANCE (Cartridge Only)

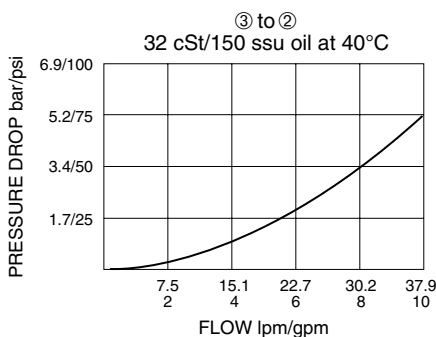

Internal Vent

PD10-35

DIMENSIONS

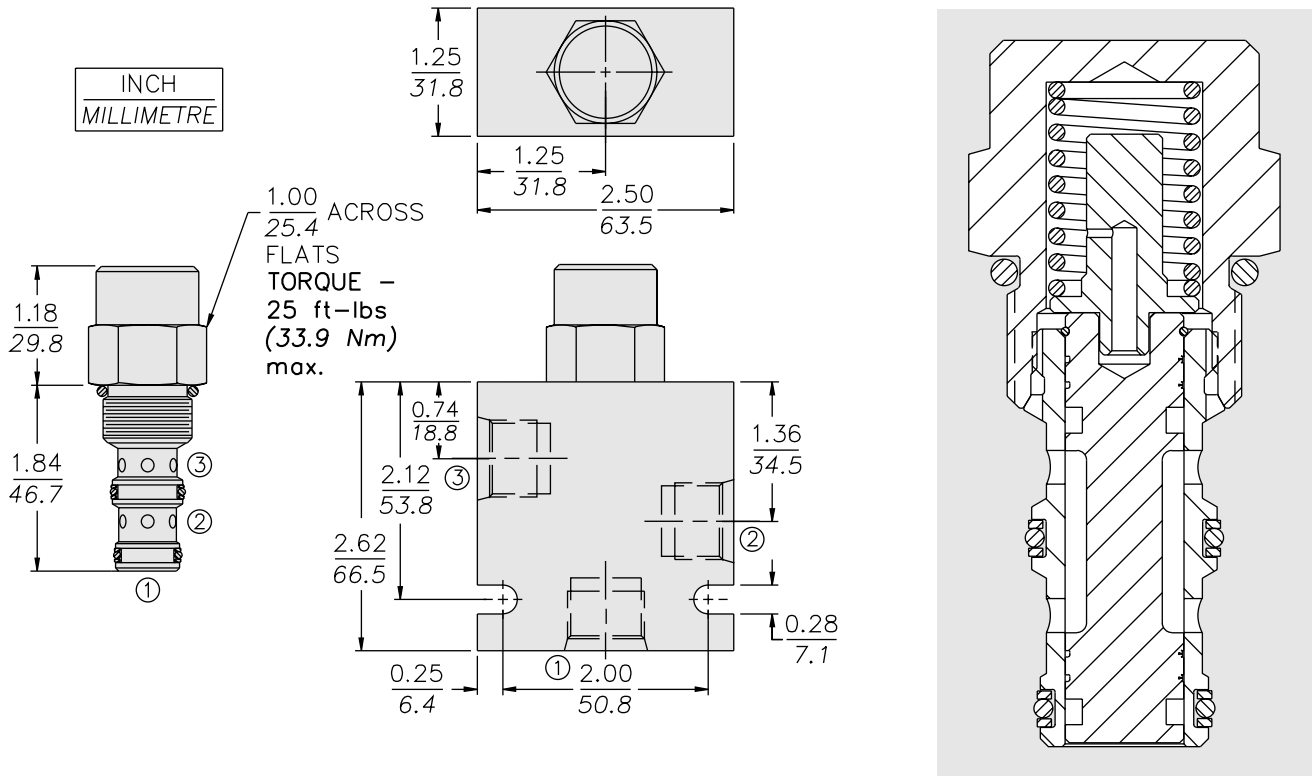

MATERIALS

Cartridge: Weight: 0.15 kg. (0.34 lbs.); Steel with hardened work surfaces; Zinc-plated exposed surfaces. Buna N O-rings and polyester elastomer back-ups standard.

Standard Ported Body: Weight: 0.36 kg. (0.80 lbs.); Anodized high-strength 6061 T6 aluminum alloy, rated to 240 bar (3500 psi); See page 8.010.1. Ductile iron and steel bodies available; dimensions may differ; consult factory.

TO ORDER

PD10-35 -

Porting
Cartridge Only **0**
SAE 6 **6T**
SAE 8 **8T**
1/4 in. BSP* **2B**
3/8 in. BSP* **3B**

*BSP Body
U.K. Mfr. Only

Bias Spring[†]
40 2.8 bar (40 psi)
60 4.1 bar (60 psi)
110 7.6 bar (110 psi)
170 11.7 bar (170 psi)

[†]Note: 110 psi bias spring is the minimum required for use with sealed spool.

Seals
N Buna N (Std.)
NS Buna N with Sealed Spool
V Fluorocarbon
VS Fluorocarbon with Sealed Spool