

DIRECTIONAL VALVES

LS10-50 Load Shuttle Network

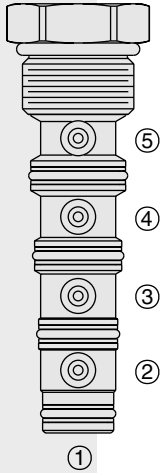

DESCRIPTION

A cartridge-style check valve network for use in hydraulic load-sense circuits.

OPERATION

The **LS10-50** will compare pressures from four circuits to provide a pressure signal from the highest pressure circuit, while blocking the other circuits.

The valve will allow flow from the highest pressure port (⑤, ④, ③ or ②) to port ①.

FEATURES

- Hardened seat for long life and low leakage.

RATINGS

Operating Pressure: 240 bar (3500 psi)

Flow: 1.89 lpm (0.5 gpm); See performance chart

Internal Leakage: 0.15 ml/minute (2 drops/minute) at 240 bar (3500 psi)

Temperature: -40 to 120°C with Buna seals

Filtration: See page 9.010.1

Fluids: Mineral-based or synthetics with lubricating properties at viscosities of 7.4 to 420 cSt (50 to 2000 sus)

Installation: No restrictions; See page 9.020.1

Cavity: VC10-5; See page 9.110.1

Cavity Tool: CT10-5XX-X-X; See page 8.600.1

Seal Kit: SK10-5X-MMMM; See page 8.650.1

SYMBOLS

USASI/ISO:

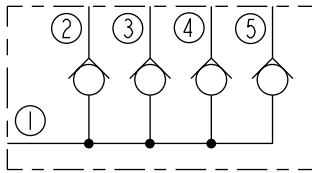

PERFORMANCE (Cartridge Only)

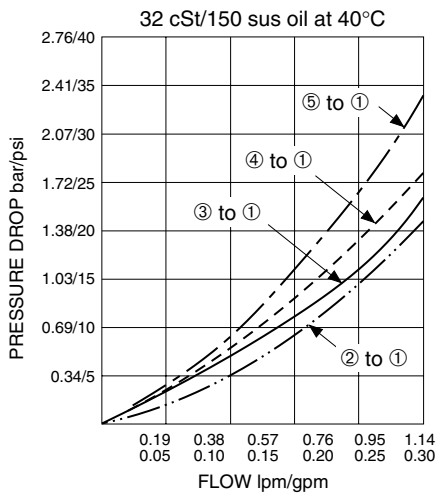

DIMENSIONS

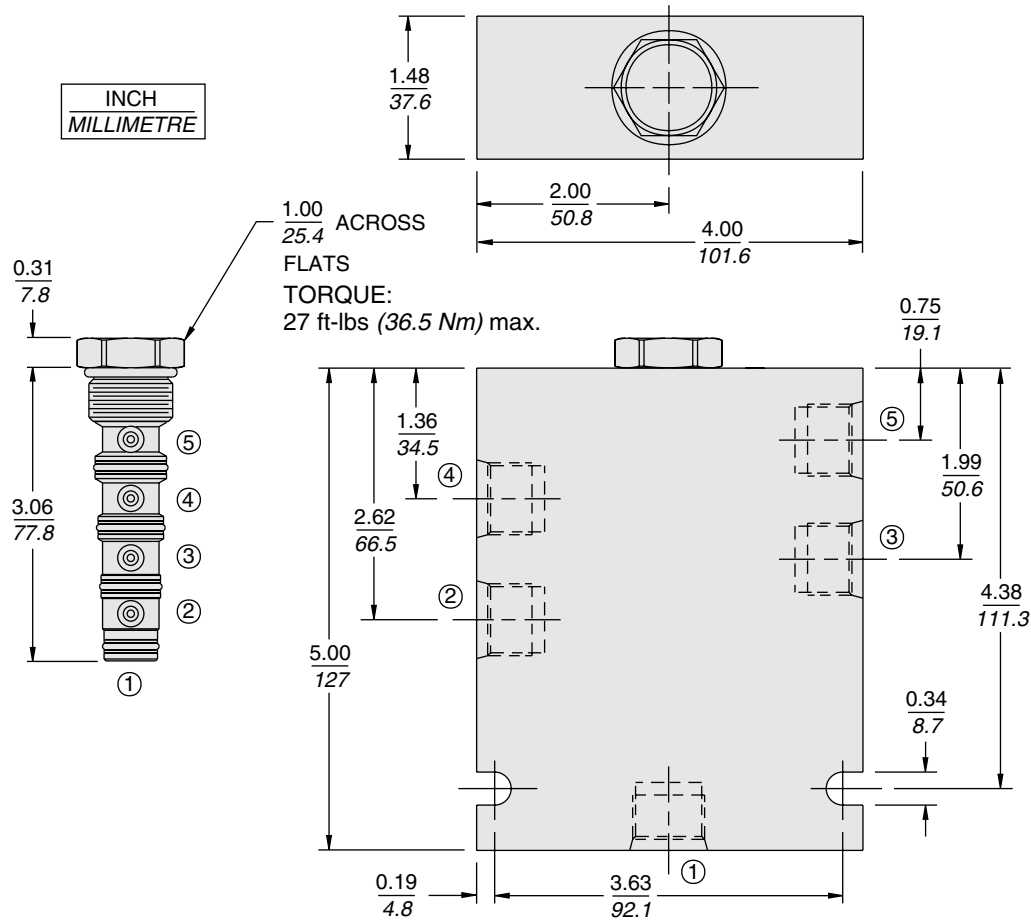

MATERIALS

Cartridge: Weight: 0.14 kg. (0.30 lbs.);
Steel with hardened work surfaces.
Zinc-plated exposed surfaces.
Buna N O-rings and polyester
elastomer back-ups standard.

Standard Ported Body: Weight:
0.41 kg. (0.85 lbs.); Anodized high-
strength 6061 T6 aluminum alloy,
rated to 240 bar (3500 psi). See
page 8.010.1. Ductile iron and steel
bodies available; dimensions may
differ; consult factory.

TO ORDER

