

DIRECTIONAL VALVES

LS50-30 Load Shuttle, Ball-Type

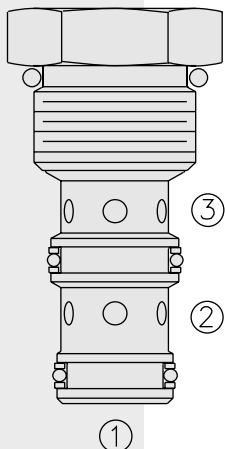

DESCRIPTION

A load-shuttling, screw-in, cartridge-style hydraulic check valve, for use in blocking circuits where a priority of flow/direction is given to a higher pressure circuit over a lower one.

OPERATION

The LS50-30 will allow flow from the higher pressure ① or ③ port to the ② port. The valve is commonly used to direct oil from the pressure side of a bidirectional hydraulic motor to a pressure-released hydraulic brake.

FEATURES

- Rapid response to load direction changes.
- Industry common cavity.

RATINGS

Operating Pressure: 345 bar (5000 psi)

Proof Pressure: 390 bar (5700 psi)

Flow: See Performance Chart

Internal Leakage: 0.25 cc/minute (5 drops/minute) max. at 345 bar(5000 psi)

Temperature: -40 to 120°C with standard Polyurethane seals

Filtration: See page 9.010.1

Fluids: Mineral-based or synthetics with lubricating properties at viscosities of 7.4 to 420 cSt (50 to 2000 ssu)

Installation: No restrictions; See page 9.020.1

Cavity: VC10-3; See page 9.110.1

Cavity Tool: CT10-3XX; See page 8.600.1

Seal Kit: SK10-3P-MM; See page 8.650.1

SYMBOLS

USASI/ISO:

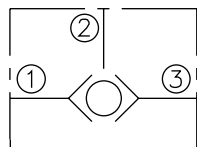

PERFORMANCE (Cartridge Only)

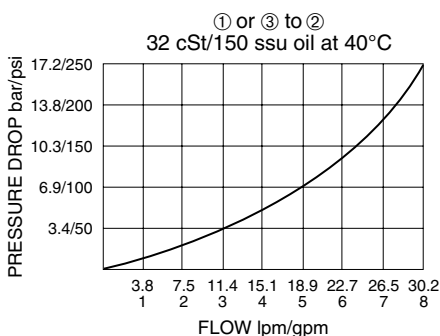

DIMENSIONS

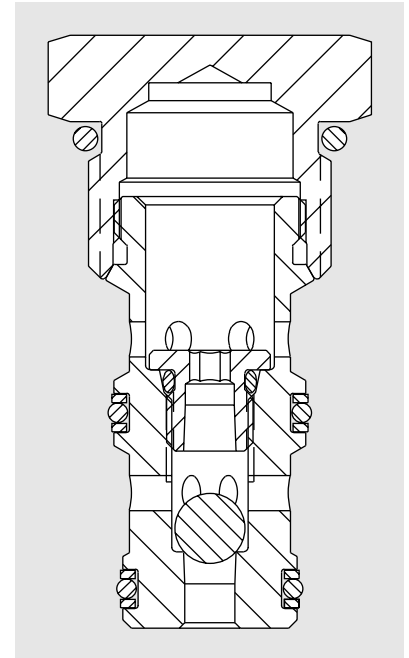
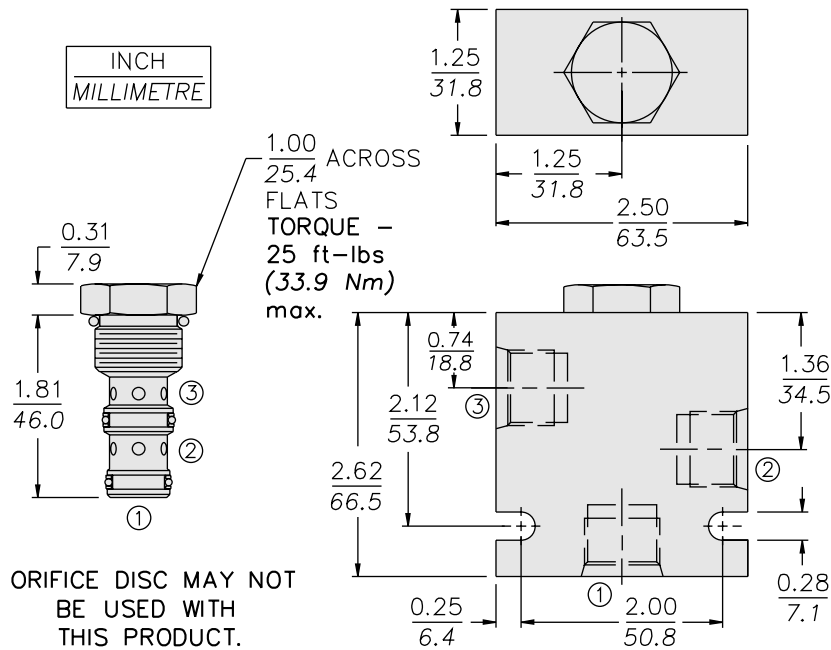

MATERIALS

Cartridge: Weight: 0.08 kg. (0.18 lbs.).
Steel; Zinc-plated exposed surfaces;
Polyurethane O-rings and
Fluorocarbon elastomer back-ups
standard.

Ported Body: Weight: 0.64 kg. (1.41 lbs.); Steel, zinc-plated (code "S"); or **Ductile Iron (code "D") standard**, consult factory for weight, dimensions may differ; rated to 345 bar (5000 psi); See page 8.010.1.

TO ORDER

