

DIRECTIONAL VALVES

LS08-30 Load Shuttle, Ball-Type

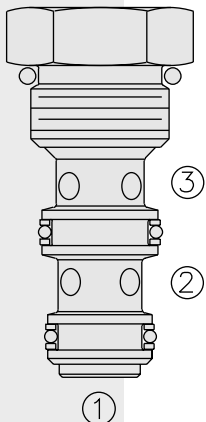

DESCRIPTION

A load-shuttling, screw-in, cartridge-style hydraulic check valve, for use in blocking circuits where a priority of flow/direction is given to a higher pressure circuit over a lower one.

OPERATION

The **LS08-30** will allow flow from the higher pressure of ① or ③ port to the ② port. The valve is commonly used to direct oil from the pressure side of a bidirectional hydraulic motor to a pressure-released hydraulic brake.

FEATURES

- Rapid response to load direction changes.
- Compact size.

RATINGS

Operating Pressure: 240 bar (3500 psi)

Proof Pressure: 390 bar (5700 psi)

Flow: See Performance Chart

Internal Leakage: 0.25 cc/minute (5 drops/minute) max. at 207 bar(3000 psi)

Temperature: -40 to 120°C with standard Buna seals

Filtration: See page 9.010.1

Fluids: Mineral-based or synthetics with lubricating properties at viscosities of 7.4 to 420 cSt (50 to 2000 ssu)

Installation: No restrictions; See page 9.020.1

Cavity: VC08-3; See page 9.108.1

Cavity Tool: CT08-3XX; See page 8.600.1

Seal Kit: SK08-3X-MM; See page 8.650.1

SYMBOLS

USASI/ISO:

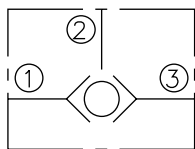

PERFORMANCE (Cartridge Only)

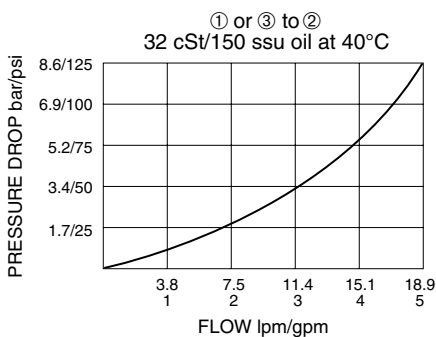

LS08-30

DIMENSIONS

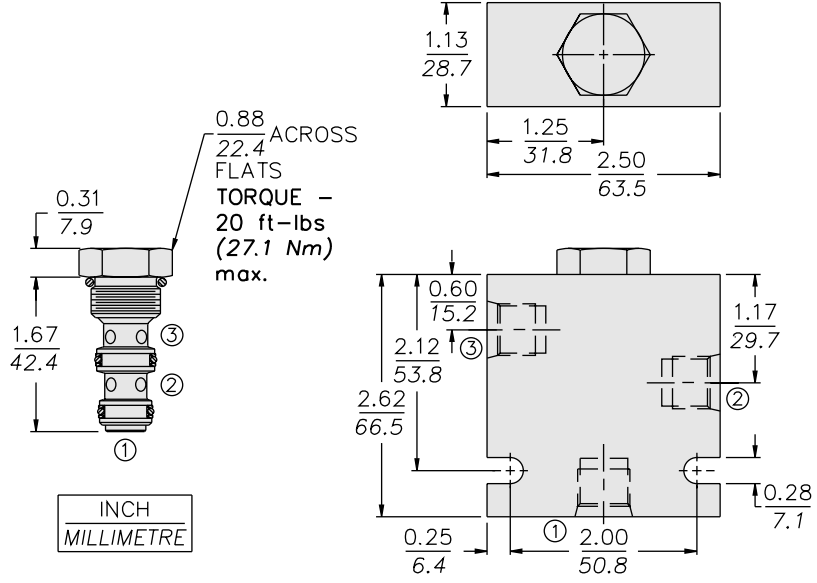

ORIFICE DISC MAY NOT BE USED WITH THIS PRODUCT.

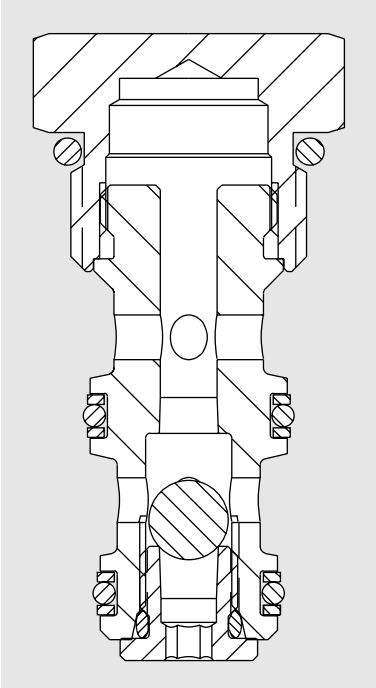

MATERIALS

Cartridge: Weight: 0.08 kg. (0.17 lbs.); Steel; Zinc-plated exposed surfaces; Buna N O-rings and back-ups standard.

Standard Ported Body: Weight: 0.27 kg. (0.60 lbs.); Anodized high-strength 6061 T6 aluminum alloy, rated to 240 bar (3500 psi). See page 8.008.1. Ductile iron and steel bodies available; dimensions may differ; consult factory.

TO ORDER

LS08-30-		-	
	Porting		Seals
Cartridge Only	0	N	Buna N (Std.)
SAE 4	4T	V	Fluorocarbon
SAE 6	6T		
1/4 in. BSP*	2B		
3/8 in. BSP*	3B		
*BSP Body U.K. Mfr. Only			